



Single-deck model shown with options.

P2X-E, P2X-EP

Excel Single or Multi-Deck
Produce Merchandiser

Husmann Excel Single or Multi-Deck Merchandiser for Produce Applications

P2X-E - Single or Multi-Deck with “High Efficiency” Coil

P2X-EP - Single or Multi-Deck with E-Plus “Extra-High Efficiency” Coil

Available in 8' and 12' lengths. Contact your sales rep for information on possible availability of additional case lengths.

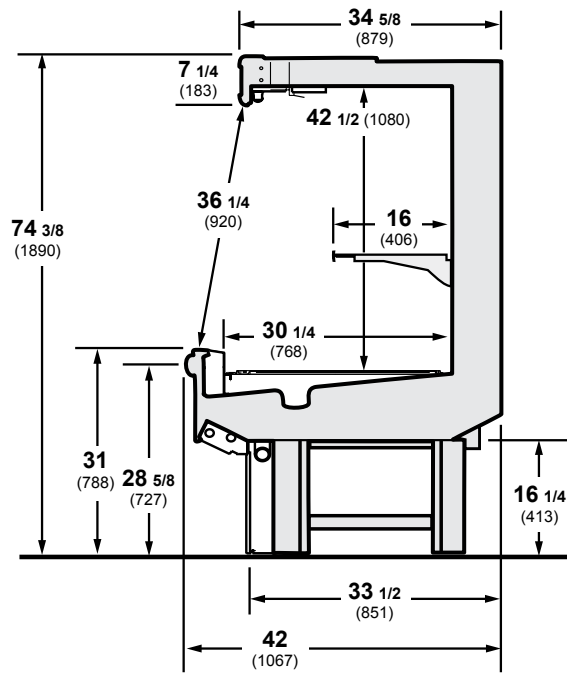

Plan View

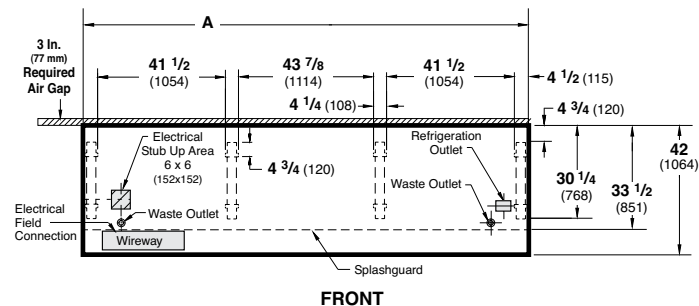

Dimension	8 FT	12 FT
A	96 3/8 (2448)	144 1/2 (3670)

Notes:

Overall case length without ends or partitions.

Note

Use Husmann’s technical data sheets to get precise dimensions for all store layout purposes.

Superior Merchandising.

The P2X creates an appealing wall of produce in both single and two deck configurations. Superior display features include full vision glass ends, illuminated canopy signs, improved ledge lighting and more.

Superior Shelf Life.

Modular coils and off-time defrost work to reduce thermal shock and stabilize product temperatures. Modular defrost, optional, can further stabilize temperatures.

Lower Labor Costs.

Labor saving features include greater clearance under the case, easy-to-clean bathtub bottom, easier raceway access, 2-ft honeycomb sections and more.

Superior Reliability.

Our five year modular coil warranty is the best available. Pre-set adjustable expansion valves are designed to hold optimal temperatures.

DOE 2017 Energy Efficiency Compliant Husmann refrigerated merchandisers configured for sale for use in the United States meet or surpass the requirements of the DOE 2017 energy efficiency standards.

NOTE: These merchandisers are designed for use in stores when temperature and humidity do not exceed 75°F and 55% R.H.

NOTE: We reserve the right to change or revise specifications and product design in connection with any feature of our products. Such changes do not entitle the buyer to corresponding changes, improvements, additions, or replacements for equipment previously sold or shipped.

For additional resources, contact your representative or visit www.husmann.com.

HUSMANN®

Husmann Corporation
12999 St. Charles Rock Rd.
Bridgeton, MO 63044-2483
Ph: 314.291.2000

www.husmann.com