



---

# P4XRO-E

Excel 4-Deck Extra Depth  
Produce Merchandiser

# Husmann Excel 4-Deck Extra Depth Produce Merchandiser

## P4XR0-E - Produce, 4-Deck, Excel, Extra Front-to-Back Depth, Low Energy

Available in 8' and 12' lengths. Contact your sales rep for information on possible availability of additional case lengths.

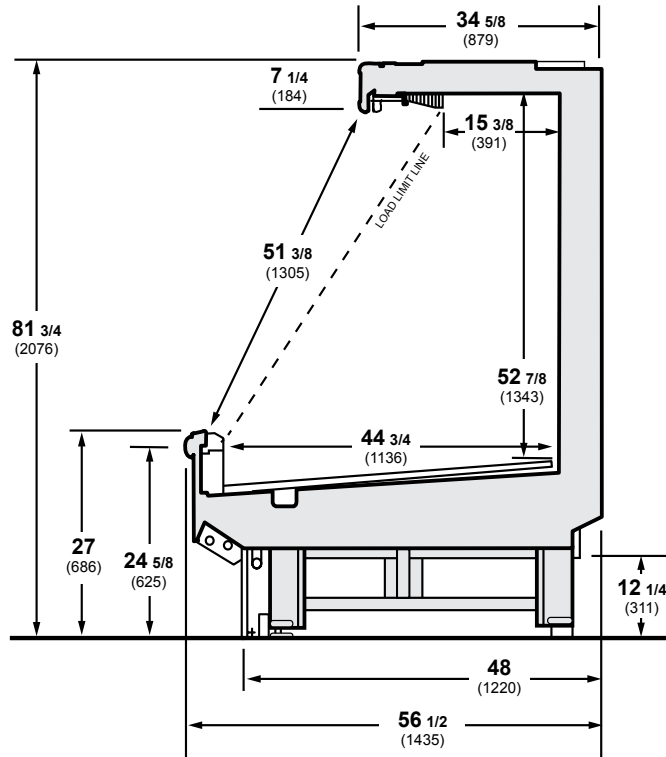

### Plan View

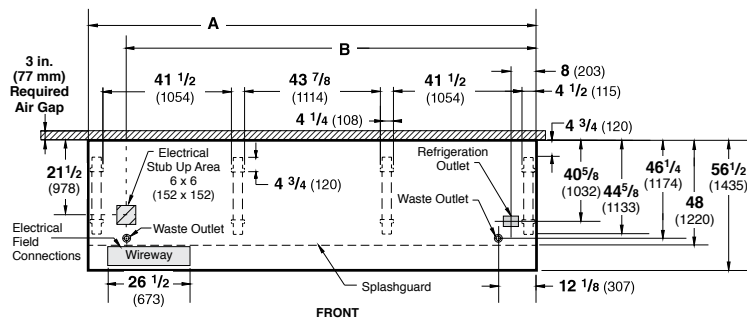

| Dimensions | 8 FT          | 12 FT          |
|------------|---------------|----------------|
| A          | 96 3/8 (2448) | 144 1/2 (3670) |
| B          | 84 1/4 (2140) | 132 3/8 (3363) |

**Notes:**  
Case-to-case electrical connections are made in front of splashguard.  
Overall case length without ends or partitions.

### Note

Use Husmann's technical data sheets to get precise dimensions for all store layout purposes.

### Superior Merchandising

The P4XR0-E creates a dramatic, highly flexible display that can be used for a wide assortment of product types. It has extra extra front-to-back depth, so that more product can be stored and displayed. Superior display options include full vision glass ends, illuminated canopy signs and improved ledge lighting. This model also allows greater shelf placement flexibility.

### Lower Energy Costs

The P4XR0-E includes energy efficient "E" coils. Night curtains can be added to further reduce energy use by about 12%.

### Superior Shelf Life

Modular coils and off-time defrost reduce thermal shock and stabilize product temperatures. Modular defrost, optional, further stabilizes temperatures.

### Lower Labor Costs

Labor saving features include greater clearance under the case, easy-to-clean "bathtub" bottom, easier raceway access, 2-ft honeycomb sections, easily removable interior panels and more.

### Superior Reliability

Our five year modular coil warranty is the best available. Pre-set, adjustable expansion valves are designed to hold optimal temperatures.

**DOE 2017 Energy Efficiency Compliant** Husmann refrigerated merchandisers configured for sale for use in the United States meet or surpass the requirements of the DOE 2017 energy efficiency standards.

**NOTE:** These merchandisers are designed for use in stores when temperature and humidity do not exceed 75°F and 55% R.H.

**NOTE:** We reserve the right to change or revise specifications and product design in connection with any feature of our products. Such changes do not entitle the buyer to corresponding changes, improvements, additions, or replacements for equipment previously sold or shipped.

For additional resources, contact your representative or visit [www.husmann.com](http://www.husmann.com).

**HUSSMANN®**

Husmann Corporation  
12999 St. Charles Rock Rd.  
Bridgeton, MO 63044-2483  
Ph: 314.291.2000

[www.husmann.com](http://www.husmann.com)