

Front View

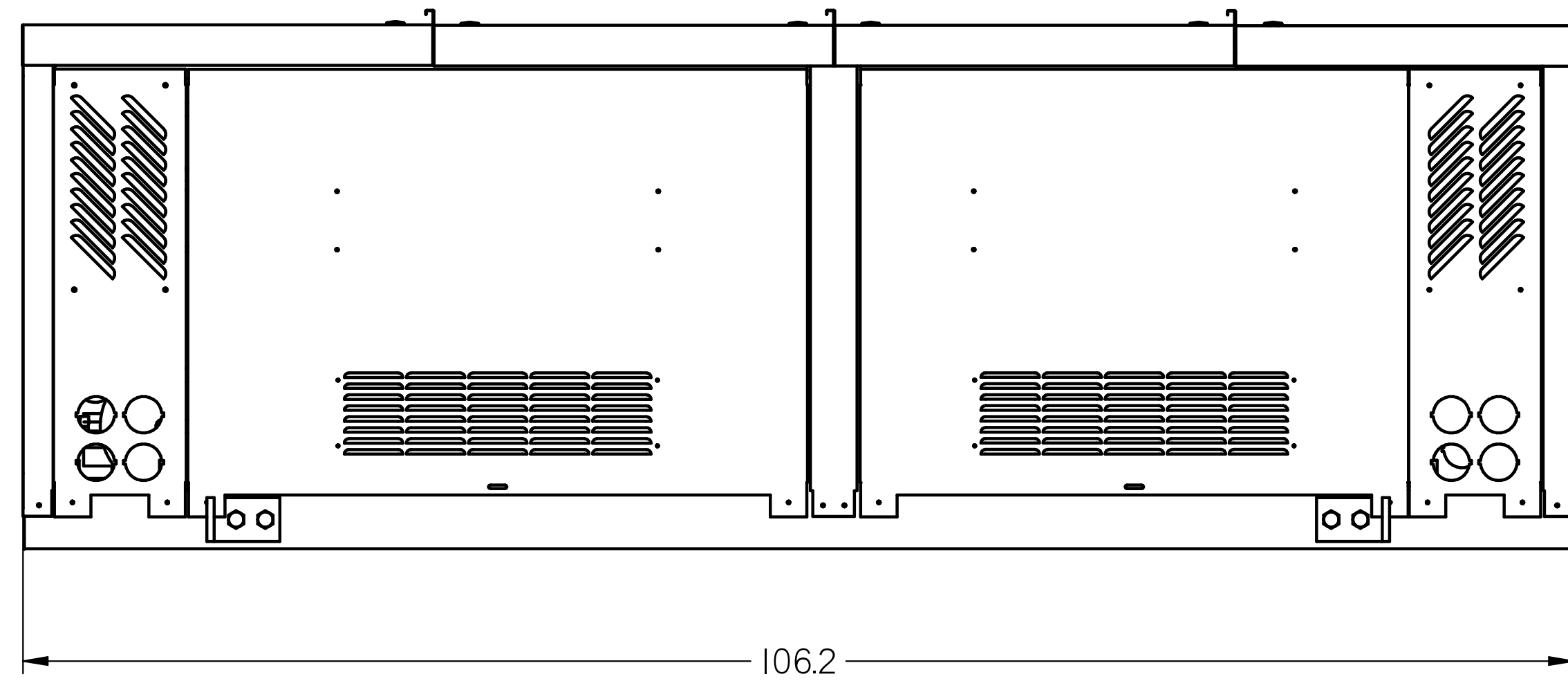

Side View

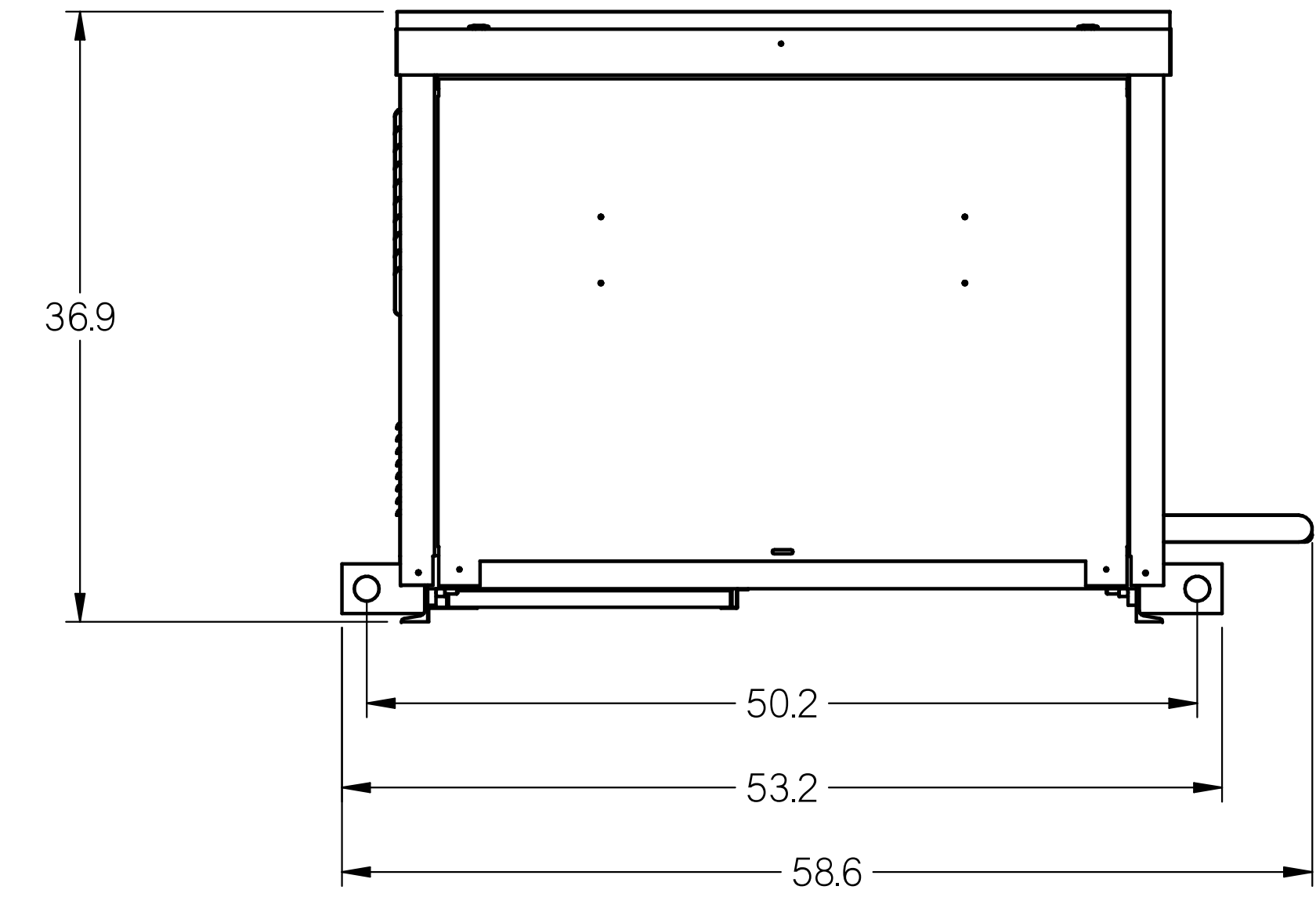

Plan View

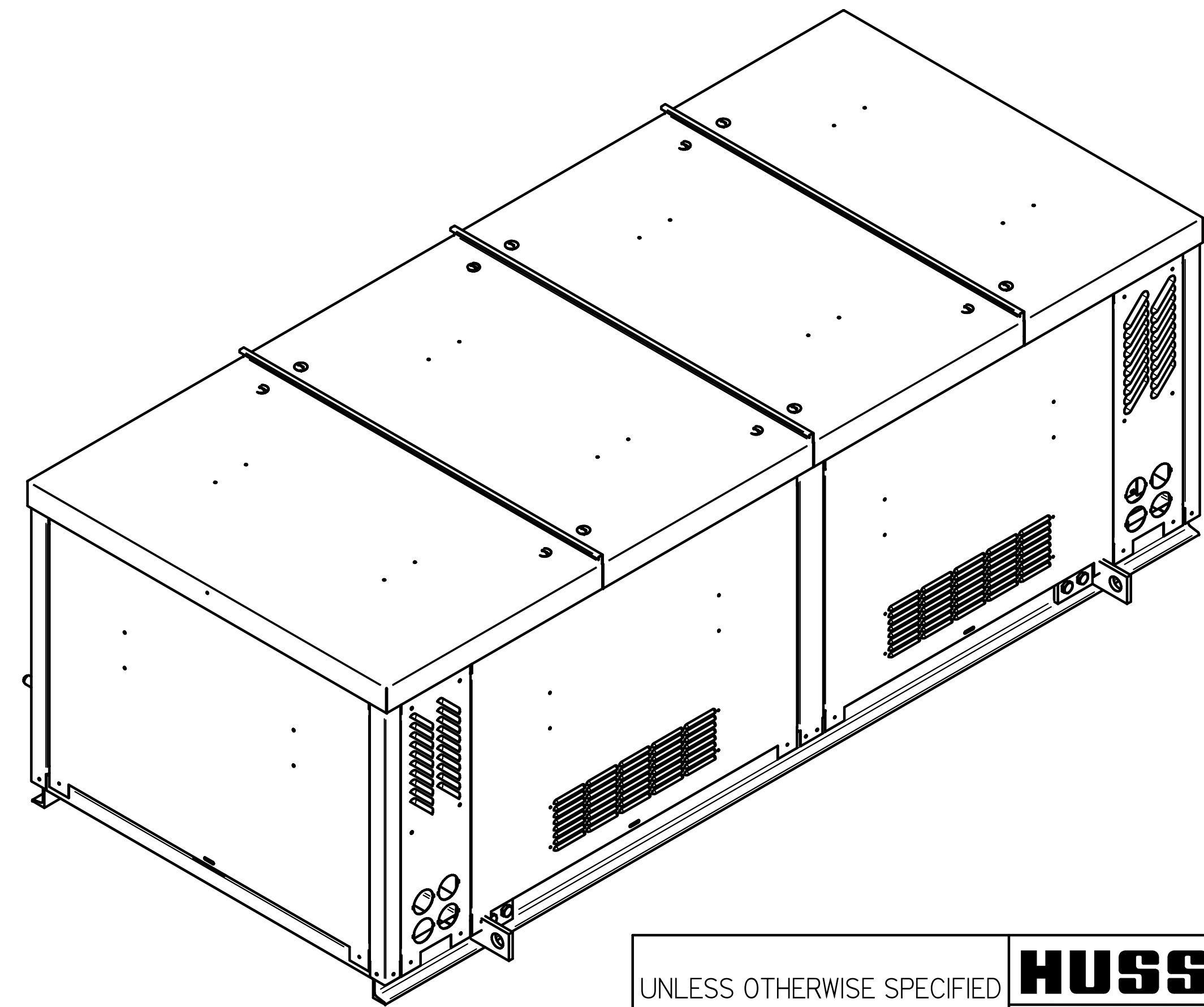
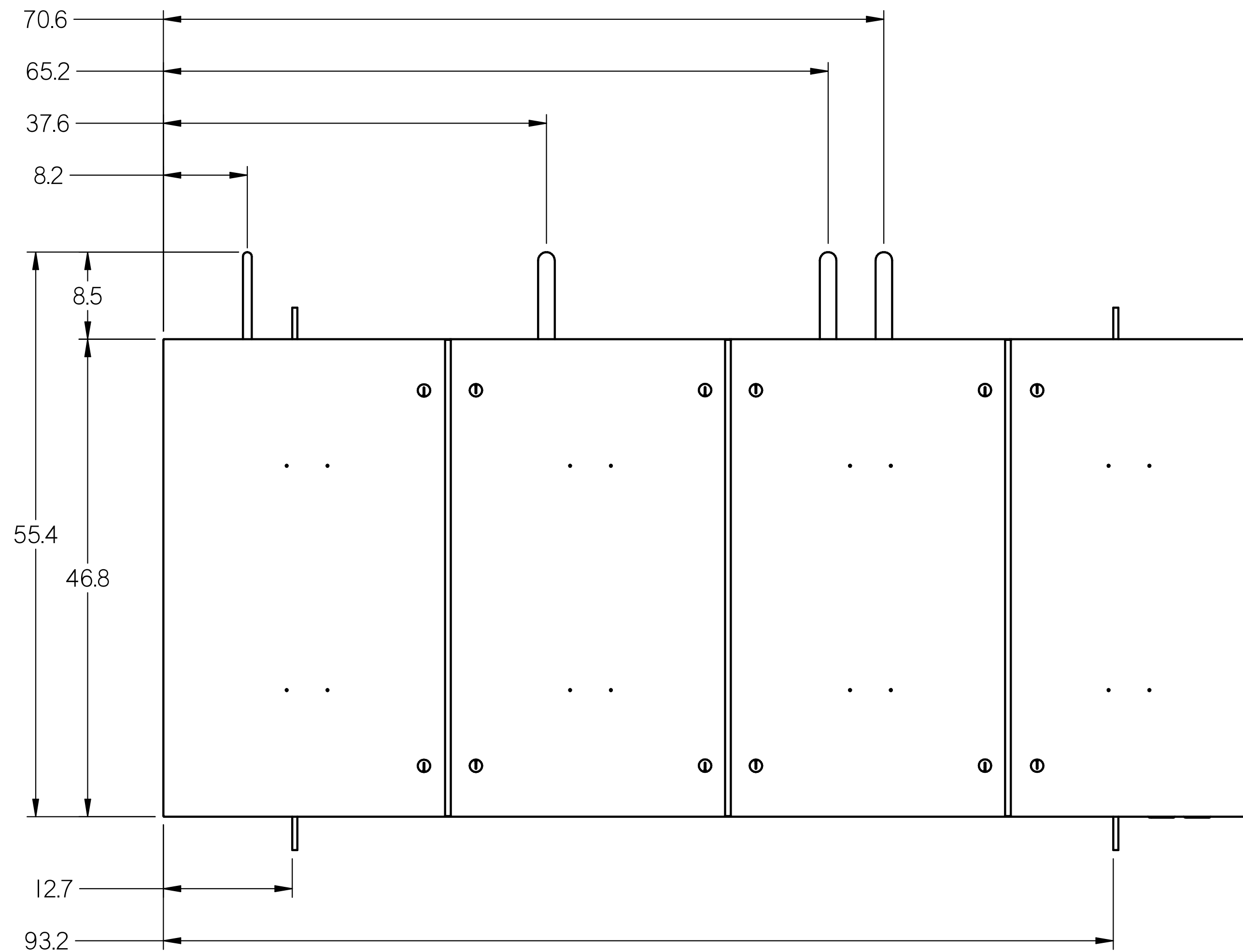

NOTES:

1. APPLICABLE STANDARDS / SPECIFICATIONS
ASME Y14.5M-1994, DIMENSIONS AND TOLERANCES
2. KEY PRODUCT CHARACTERISTICS PER EPR-0006 & IDENTIFIED WITH SYMBOL 
3. MATERIAL-
4. REF- Reference
5. TOLERANCES: LINEAR DIMENSION IS ± 0.63 .
ANGLE DIMENSION IS $\pm 2^\circ$.

UNLESS OTHERWISE SPECIFIED
DIMENSIONS ARE IN INCHES.

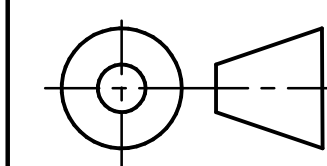

THIRD
ANGLE
PROJECTION

HUSSMANN[®]
SPO PROTOCOL

SHEET 1 OF 2

P/N

REV

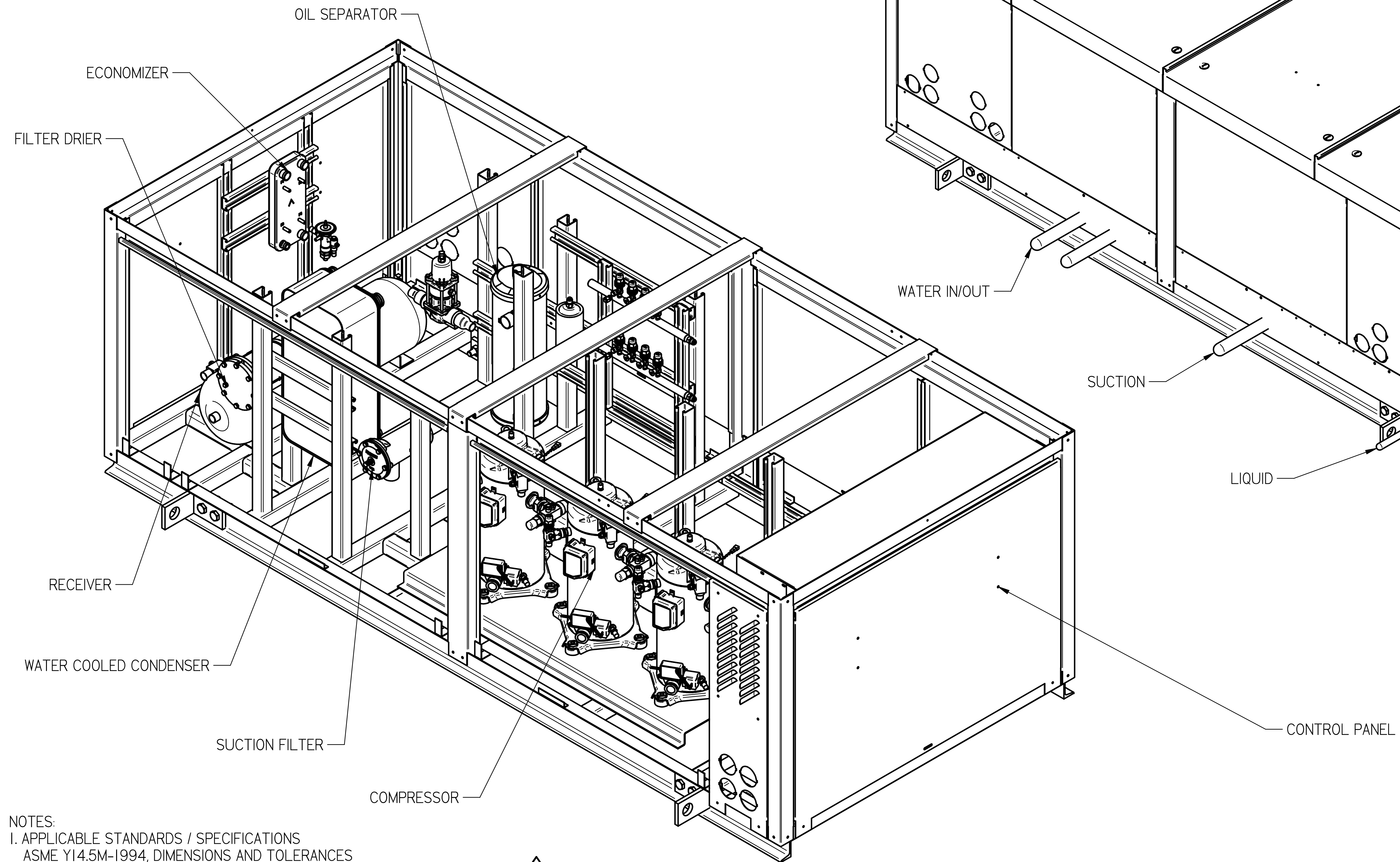

NOTES:

1. APPLICABLE STANDARDS / SPECIFICATIONS
ASME Y14.5M-1994, DIMENSIONS AND TOLERANCES
2. KEY PRODUCT CHARACTERISTICS PER EPR-0006 & IDENTIFIED WITH SYMBOL 
3. MATERIAL-
4. REF- Reference
5. TOLERANCES: LINEAR DIMENSION IS ± 0.063 .
ANGLE DIMENSION IS $\pm 2^\circ$.

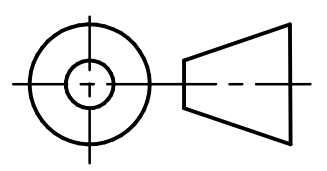
 THIRD ANGLE PROJECTION	HUSSMANN [®]	
	SPO PROTOCOL	
SHEET 2 OF 2	PIN	REV