

Specialty



Q-Series Family

Q3-M/FS-EP

Multi-Deck Merchandiser with Straight Glass
for Meat and Seafood (non ice) Applications

*Enhanced Performance with **OptiCool™** Technology*

Husmann Q-Series Multi-Deck Merchandiser with Straight Glass for Meat and Seafood (non ice) Applications

Q3-M/FS-EP

Increase shelf life. Save 35% on Energy†



EXTENDED Bloom

For optimum performance, reference the merchandising requirements †

Enhanced performance with **OptiCool™ Technology**

- Reduces dehydration by 60%‡
- Increases humidity by 12%‡
- Reduces temperature variance‡

Reduced system complexity, costs

- Simple installation
- All DX refrigeration at +28° F evap
- No glycol pump station required



EcoShine II Plus LEDs (Standard)

- 85+ CRI for bringing out natural colors (especially meat, deli and seafood)
- Diffused lighting eliminates pixilation, hot spots on product packaging
- Increased reliability with industry leading IP67 certification

Clear View

Heated air sweep eliminates glass sweating to provide clear, unobstructed food product views



Merchandise With Optional 'Easy Shelf'

Removable 12" stainless steel 'Easy Shelf' provides added display and extra merchandising space all in a small footprint

Ergonomics

Large rear door opening and angled back improves product access.

Remote Lengths: 4', 6', 8', and 12'

Q3-M/FS-EP Service Meat or Fish

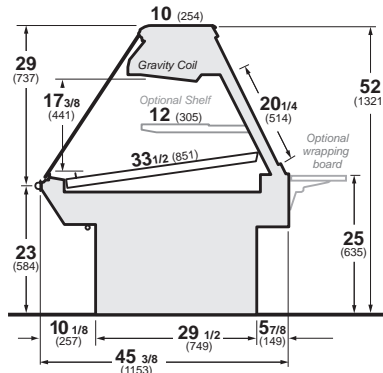

Q3-M/F-EP

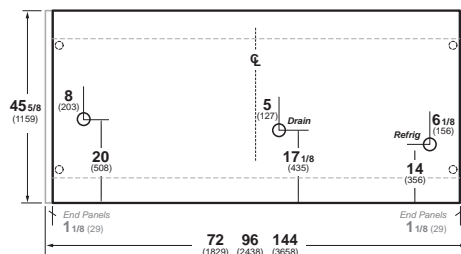

Features.

- Anti reflective, tempered, lift-up, straight front clear glass
- Large clear glass sliding rear doors
- Gravity/conduction coil (Meat)
- Gravity coil, conduction coil (non ice) (Fish)
- EcoShine II IP67 rated LED lights
- Stainless steel interior pans
- Adjustable deck for flexible merchandising
- Adjustable stainless steel legs
- Stainless steel top cover
- Black matrix on the glass to hide the coil
- Black powder-coated coil cover
- Solar digital thermometer
- Front glass air sweep
- Digital thermostat and suction stop installed
- Black vinyl cart bumper
- Please reference color chart for choice of standard Husmann paint and finish options (www.husmann.com)

Options.

- Coil corrosion protective coating
- 12" stainless steel removable Easy Shelf
- Automatic or manual water flush (reduces the need for manual case cleaning)
- Corian®, granite or other solid surface front and/or top ledge (NSF approved material)
- Mirrored rear doors
- Thermoplastic wrapping boards w/adjustable riser
- View or solid ends
- Mirror bright stainless steel inside end panels
- Stainless steel pedestals
- Top mounted scale stand extensions with dedicated scale outlet and Cat 5 scale connections
- Liquid line shut-off hand valve
- 15 amp GFCI duplex outlet
- Custom trim and decor
- Custom lengths and options* (consult your Husmann sales representative)
- Special exterior finishes* (consult your Husmann sales representative)

Additional Information.

- Q-Series Entire Family: Q-Series Family

DOE 2017 Energy Efficiency Compliant

Husmann refrigerated merchandisers configured for sale for use in the United States meet or surpass the requirements of the DOE 2017 energy efficiency standards.

* Some optional features may need to be certified by UL, NSF, and/or other 3rd party certification agencies. Contact Husmann for verification or questions for availability.

† For optimum performance product must be in direct contact of the deck. Reference detailed merchandising requirements located in the Installation guide @ www.husmann.com

‡ Performance results based on equivalent standard Husmann models

NOTE: These merchandisers are designed for use in stores when temperature and humidity do not exceed 75°F and 55% R.H. We reserve the right to change or revise specifications and product design in connection with any feature of our products. Such changes do not entitle the buyer to corresponding changes, improvements, additions, or replacements for equipment previously sold or shipped.



Note. Use Husmann's technical data sheets to get precise dimensions for all store layout purposes.

Intertek Intertek

HUSMANN®

Husmann Corporation
13770 Ramona Avenue
Chino, California 91710
Ph: 1-800.395.9229

www.husmann.com