

HUSSMANN®

Impact™ Merchandisers



microDS™

RL-SP

Self-Contained Propane R290
Natural Refrigerant Merchandiser

Reach-In with Innovator Doors and Low Front
for Frozen Food Applications

www.hussmann.com

Available in 2, 3, 4 and 5 doors.

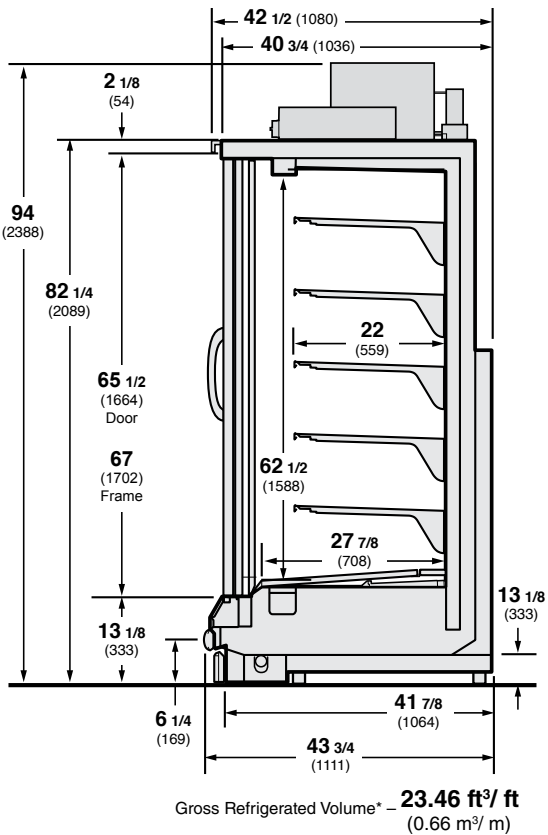

Features / Benefits

- Environmentally-friendly R290 hydrocarbon refrigerant that has zero ozone depletion (ODP) potential and 3 Global Warming Potential (GWP)
- Ideal for any low temperature for frozen food products
- Available with Hussmann Innovator and Innovator III doors
- Merchandiser rejects heat through a continuous flow water-loop system at store level operating between 45° and 80°F inlet temperature
- UL, NSF Type I and DOE 2017 certified
- **Superior Merchandising and Flexibility**
 - High pack-out in limited footprint allowing more product in the same space
 - EcoShine II LED lights reduce relamping and other maintenance costs, and can be customized for optimal product lighting
 - Fan plenums can be detached from coil for easy-to-clean case bottom
 - CoreLink controller remote performance monitoring available

Standard Features

- Color Interior/Exterior: Black, Grey, White
- Exterior Sign Panel: None
- Number of Display Levels: 6
- LED Lighting: Mullion
- Adjustable Leveling Legs: No
- Casters: No
- Hardwired: Yes
- Insulation: Polyurethane Foam - CFC Free

Optional Accessories

- Lift-out bottom rack for easier cleaning/service
- Heavy-duty front panels and deck pans
- Additional display shelves available - Max of 6 per door
- Bumper - Front and ends
- Price tag molding
- Product stops
- Heavy-duty shelves

Plan View

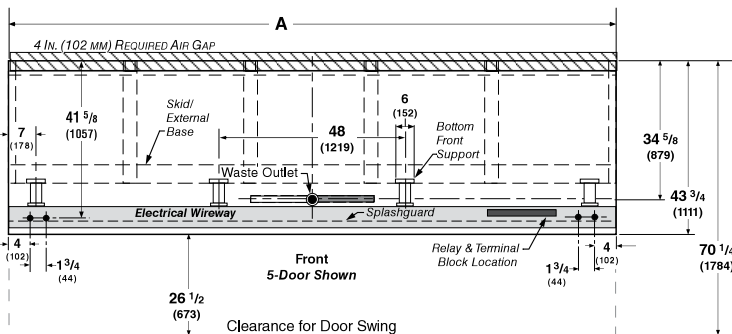

Dimensions	2 DOOR	3 DOOR	4 DOOR	5 DOOR
A	62 (1575)	92 1/2 (2350)	122 7/8 (3121)	153 3/8 (3896)

Note: Contact your sales representative for information on possible availability of additional case lengths.

Note

Use Hussmann's technical data sheets to get precise dimensions for all store layout purposes.



NOTE: These merchandisers are designed for use in stores when temperature and humidity do not exceed 75°F (23.9°C) and 55% R.H.

NOTE: We reserve the right to change or revise specifications and product design in connection with any feature of our products. Such changes do not entitle the buyer to corresponding changes, improvements, additions, or replacements for equipment previously sold or shipped.

Hussmann Corporation

12999 St. Charles Rock Rd.
Bridgeton, MO 63044-2483
Ph: 314.291.2000

www.hussmann.com