

HUSSMANN®

Impact™ Merchandisers



microDS™

RLN-W

Self-Contained Propane R290
Natural Refrigerant Merchandiser

Narrow Reach-In with Innovator Doors
for Frozen Food Applications

www.hussmann.com



Available in 2, 3, 4 and 5 doors.

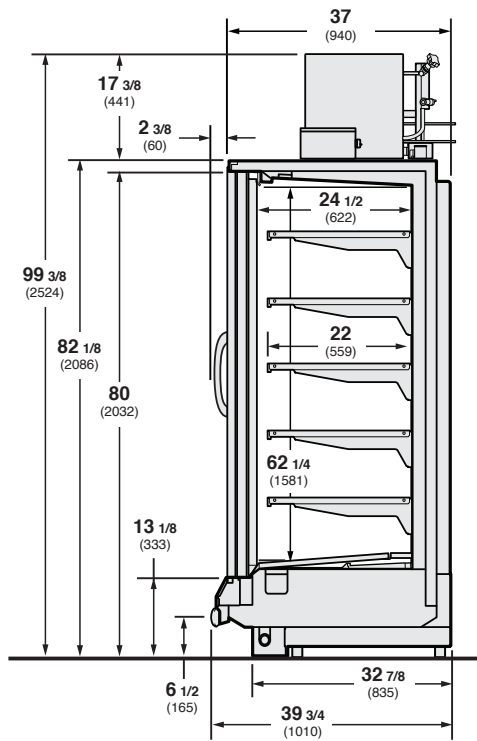

Gross Refrigerated Volume* – **22.80 ft³/ft**
(0.65 m³/m)

*per ANSI/AHRI 1200-2013 appendix C. Volume Calculation



L21-20P



L21-30P



Features / Benefits

- Ideal for any low temperature or frozen food products
- Available with Hussmann Innovator and Innovator III doors
- Merchandiser rejects heat through a continuous flow water-loop system at store level
- Water-loop system operates between 50° and 115°F inlet water temperatures
- Environmentally-friendly R290 hydrocarbon refrigerant that has zero ozone depletion potential (ODP) and 3 Global Warming Potential (GWP)
- High capacity, factory-balanced refrigeration system capable of maintaining ice cream temperature
- UL, NSF Type II and DOE 2017 certified
- **Superior Merchandising and Flexibility**
 - 18, 20 and 22 inch shelves available for flat merchandising
 - The display area per door is identical to the capacity of the standard depth RL
 - EcoShine II LED customized for optimal product lighting
 - Standard LED lights reduce relamping and other maintenance costs
 - High pack-out in limited footprint allowing more product in the same space
 - Fan plenums can be detached from coil for easy-to-clean case bottom
 - CoreLink controller remote performance monitoring available

Standard Features

- Color Interior/Exterior: Black, Grey, White
- Exterior Sign Panel: None
- LED Lighting: Mullion
- Number of display levels: 6
- Adjustable Leveling Legs: No
- Casters: No
- Power Cord: 3 phase, 20A/208V or 30A/208V, NEMA L21-20P, L21-30P
- Hardwired: No
- Insulation: Polyurethane Foam - CFC Free

Optional Accessories

- Lift-out bottom rack for easier cleaning/service
- Heavy-duty front panels and deck pans
- Additional display shelves available – Max of 5 per door
- Bumper – Front and ends
- Price tag molding
- Product stops
- Contour fascia option
- Heavy-duty shelves

Plan View

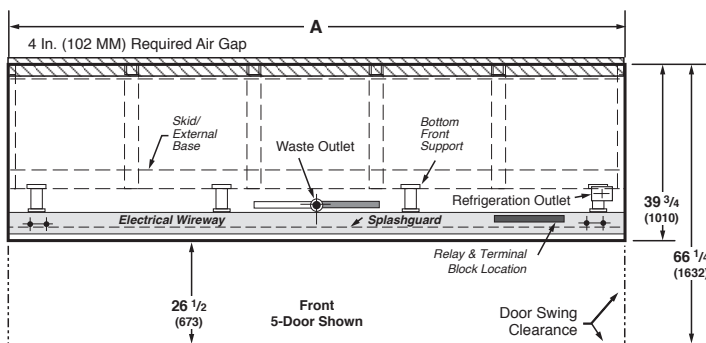

Dimensions	2 DOOR	3 DOOR	4 DOOR	5 DOOR
A	62 (1575)	122 7/8 (3121)	122 7/8 (3121)	153 3/8 (3896)

Note: Contact your sales representative for information on possible availability of additional case lengths.

Note

Use Hussmann’s technical data sheets to get precise dimensions for all store layout purposes.

DOE 2017 Energy Efficiency Compliant Hussmann refrigerated merchandisers configured for sale for use in the United States meet or surpass the requirements of the DOE 2017 energy efficiency standards.

NOTE: These merchandisers are designed for use in stores when temperature and humidity do not exceed 75°F (23.9°C) and 55% R.H.

NOTE: We reserve the right to change or revise specifications and product design in connection with any feature of our products. Such changes do not entitle the buyer to corresponding changes, improvements, additions, or replacements for equipment previously sold or shipped.

Hussmann Corporation

12999 St. Charles Rock Rd.
Bridgeton, MO 63044-2483
Ph: 314.291.2000

www.hussmann.com

