



RLTIM

Back-to-Back, Extra Tall Island Reach-In
for Frozen Food and Ice Cream Applications

Available with Hussmann Innovator,
Innovator I LE or Innovator III Glass Doors

Husmann Back-to-Back, Extra Tall Island Reach-In for Frozen Food and Ice Cream Applications

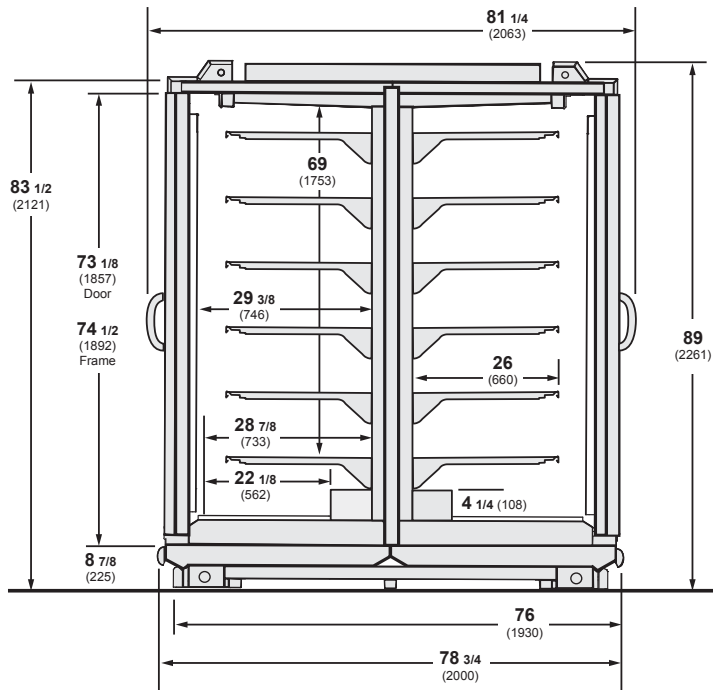

RLTIM - Reach-In, Low Temp, Extra Tall, Back-to-Back Island, Maximized Performance

Available in 4, 6, 8 and 10 door configurations.

Features and Benefits

- The RLTIM is an extra tall island reach-in case designed for maximum energy savings, refrigeration performance and merchandising impact.
- The RLTIM with original Innovator 1 doors provides exceptional performance even in higher ambient conditions and is compliant with DOE 2012. Innovator I LE and Innovator III doors also available.
- Suitable for heavy shopping environments.
- Superior energy efficiency.
- Excellent product temperature consistency throughout the refrigerated space.
- Now allows use of 26" shelves, increasing merchandise pack-out.
- Coil now mounted in case bottom for larger cubic capacity.
- Bottom deck is nearly 22" deep for optimal merchandise pack-out.

Options Include

- Up to 26" shelves.
- Various shelves, racks, lighting, paint and bumper colors.
- Innovator, Innovator I LE and Innovator III doors.

Plan View

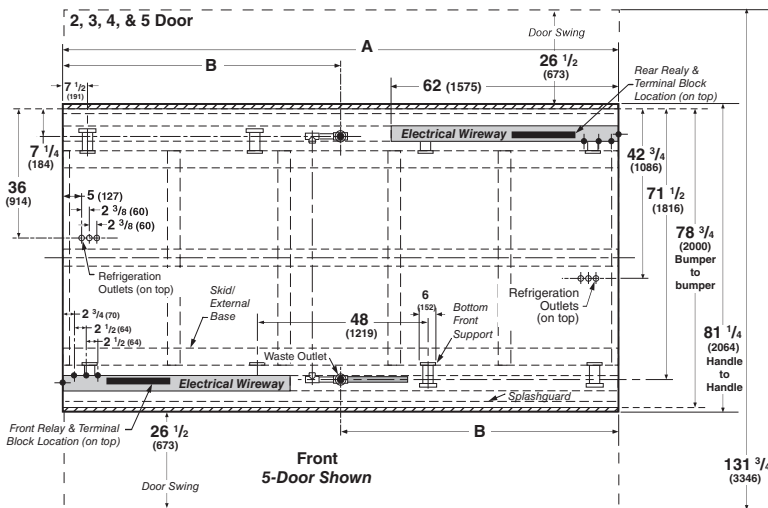

Dimension	A	B	Notes:
2 Door	62 (1575)	23 7/8 (606)	Overall case length without ends or partitions. Each standard end and each insulated partition adds 2 3/4 in. (70mm) to case line up.
3 Door	92 1/2 (2350)	54 1/4 (1378)	
4 Door	122 7/8 (3121)	46 1/4 (1175)	
5 Door	153 3/8 (3896)	76 5/8 (1946)	

Note

Use Husmann's technical data sheets to get precise dimensions for all store layout purposes.



Husmann refrigerated merchandisers configured for sale for use in the United States meet or surpass the requirements of the DOE 2017 energy efficiency standards.

NOTE: These merchandisers are designed for use in stores when temperature and humidity do not exceed 75°F and 55% R.H.

NOTE: We reserve the right to change or revise specifications and product design in connection with any feature of our products. Such changes do not entitle the buyer to corresponding changes, improvements, additions, or replacements for equipment previously sold or shipped.

For additional resources, contact your representative or visit www.husmann.com.



Husmann Corporation
12999 St. Charles Rock Rd.
Bridgeton, MO 63044-2483
Ph: 314.291.2000

www.husmann.com