



RLTM

RLTM, RMTM

Extra Tall Reach-In for Frozen Food, Ice Cream
and Medium Temp Applications

Husmann Extra Tall Reach-In for Frozen Food, Ice Cream and Medium Temperature Applications

RLTM - Reach-In, Low Temp, Extra Tall, Maximized Performance

RMTM - Reach-In, Medium Temp, Extra Tall, Maximized Performance

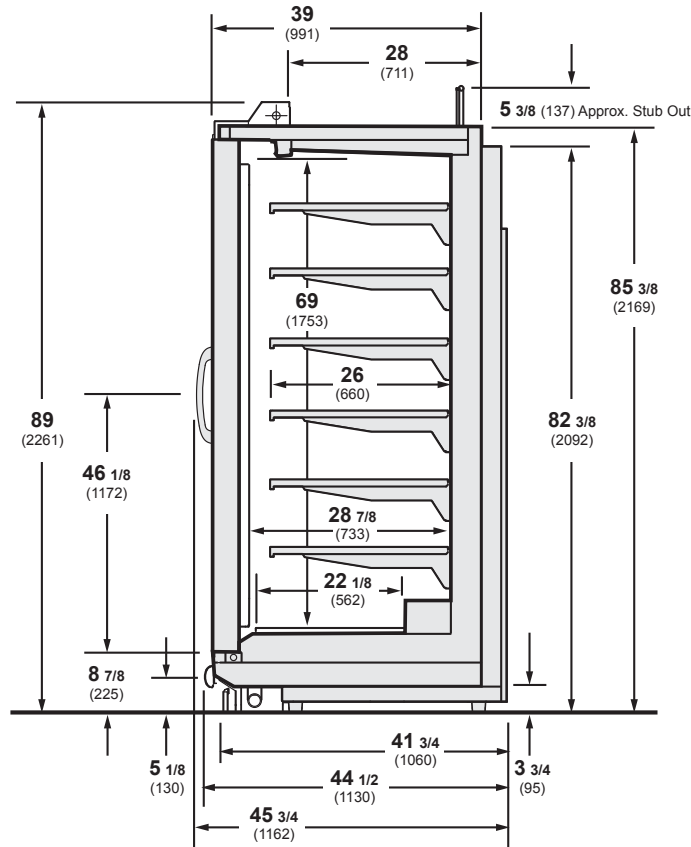

Plan View

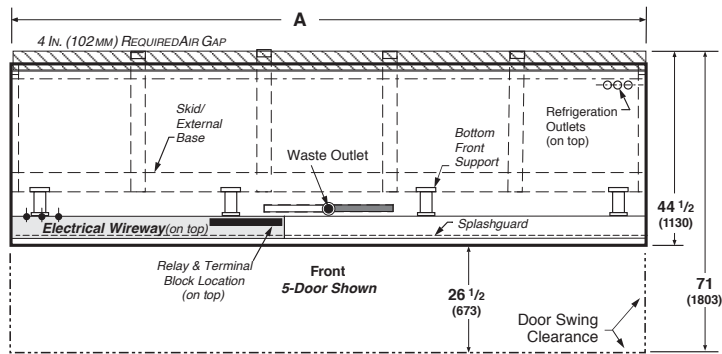

Dimensions	2 DOOR	3 DOOR	4 DOOR	5 DOOR
A	62 (1575)	92 1/2 (2350)	122 7/8 (3121)	153 3/8 (3896)

Note

Use Husmann's technical data sheets to get precise dimensions for all store layout purposes.

Features and Benefits

- The RLTM and RMTM are extra tall reach-in cases designed for maximum energy savings, refrigeration performance and merchandising impact.
- The RLTM with original Innovator 1 doors provides exceptional performance even in higher ambient conditions and is compliant with DOE 2012. Innovator I LE and Innovator III doors also available.
- Suitable for heavy shopping environments.
- Superior energy efficiency.
- Excellent product temperature consistency throughout the refrigerated space.
- Now allows use of 26" shelves, increasing merchandise pack-out.
- Coil now mounted in case bottom for larger cubic capacity.
- Top aligns with existing RLT and RMT models to enable line-up extensions.
- Bottom deck is nearly 22" deep for optimal merchandise pack-out.
- Front to back case dimension, including rear air gap, is no larger than previous RLT and RMT models. Case fits in same footprint as previous RLT and RMT models.

Options Include

- Up to 26" shelves now available for these models.
- Various shelves, racks, lighting, paint and bumper colors.
- Innovator, Innovator I LE and Innovator III doors available.



Husmann refrigerated merchandisers configured for sale for use in the United States meet or surpass the requirements of the DOE 2017 energy efficiency standards.

NOTE: These merchandisers are designed for use in stores when temperature and humidity do not exceed 75°F and 55% R.H.

NOTE: We reserve the right to change or revise specifications and product design in connection with any feature of our products. Such changes do not entitle the buyer to corresponding changes, improvements, additions, or replacements for equipment previously sold or shipped.

For additional resources, contact your representative or visit www.husmann.com.

HUSSMANN®

Husmann Corporation
12999 St. Charles Rock Rd.
Bridgeton, MO 63044-2483
Ph: 314.291.2000

www.husmann.com