

HUSSMANN®

Impact™ Merchandisers



microDS™

RMN-W

Self-Contained Propane R290
Natural Refrigerant Merchandiser

Narrow Reach-In with Innovator Doors
for Deli, Dairy and Beverage Applications

www.hussmann.com



Husmann Self-Contained Propane R290 Natural Refrigerant Merchandiser

Impact Water-Cooled Narrow Reach-In with Innovator Doors for Deli, Dairy and Beverage Applications

Available in 2, 3, 4, and 5 doors.

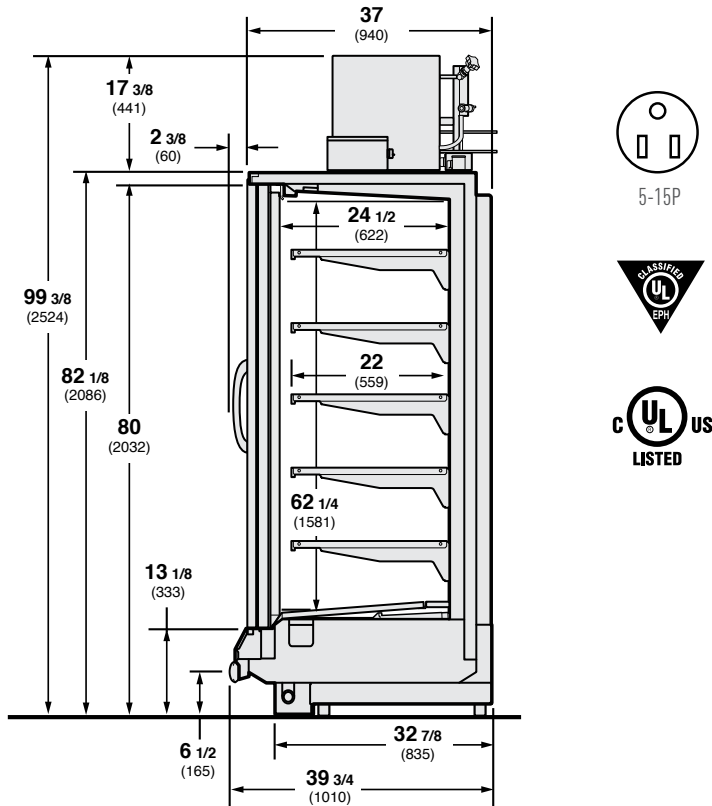

Gross Refrigerated Volume* – **23.46 ft³/DR**
(0.66 m³/DR)

*per ANSI/AHRI 1200-2013 appendix C. Volume Calculation

Plan View

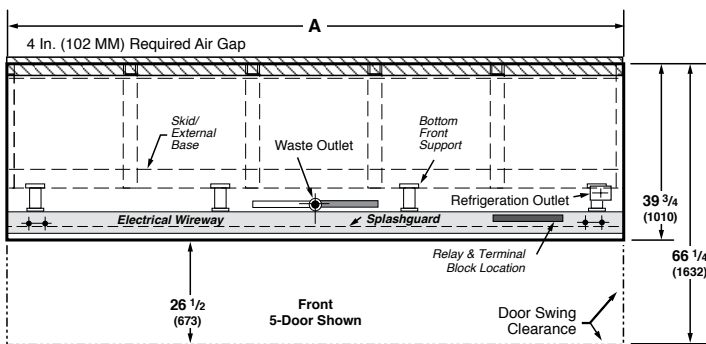

Dimensions	2 DOOR	3 DOOR	4 DOOR	5 DOOR
A	62 (1575)	92 1/2 (2350)	122 7/8 (3121)	153 3/8 (3896)

Note: Contact your sales representative for information on possible availability of additional case lengths.

Note

Use Husmann's technical data sheets to get precise dimensions for all store layout purposes.

Features / Benefits

- Environmentally-friendly R290 hydrocarbon refrigerant that has zero ozone depletion potential (ODP) and 3 Global Warming Potential (GWP)
- Ideal for any medium temperature or beverage products
- Available with Husmann Innovator and Innovator III doors
- Merchandiser rejects heat through a continuous flow water-loop system at store level between 50° and 115°F inlet temperature
- UL, 4L EPH and DOE 2017 certified
- **Superior Merchandising and Flexibility**
 - 22 inch shelves available for flat merchandising
 - The display area per door is identical to the capacity of the standard depth RL
 - EcoShine II LED lights reduce relamping and other maintenance costs, and can be customized for optimal product lighting
 - High pack-out in limited footprint allowing more product in the same space
 - CoreLink controller with web browser interface to view performance data/logs and alarm information

Standard Features

- Color Interior/Exterior: Black, Grey, White
- Exterior Sign Panel: None
- LED Lighting: Mullion
- Number of Display Levels: 6
- Adjustable Leveling Legs: No
- Casters: No
- Hardwired: No
- Insulation: Polyurethane Foam - CFC Free

Optional Accessories

- Lift-out bottom rack for easier cleaning/service
- Heavy-duty front panels and deck pans
- Additional display shelves available – Max of 5 per door
- Bumper – Front and ends
- Price tag molding
- Product stops
- Heavy-duty shelves
- Power cord



Husmann refrigerated merchandisers configured for sale for use in the United States meet or surpass the requirements of the DOE 2017 energy efficiency standards.

NOTE: These merchandisers are designed for use in stores when temperature and humidity do not exceed 75°F (23.9°C) and 55% R.H.

NOTE: We reserve the right to change or revise specifications and product design in connection with any feature of our products. Such changes do not entitle the buyer to corresponding changes, improvements, additions, or replacements for equipment previously sold or shipped.

Husmann Corporation

12999 St. Charles Rock Rd.
Bridgeton, MO 63044-2483
Ph: 314.291.2000

www.husmann.com

