

HUSSMANN®

Specialty



SGB

Service Merchandiser with Straight Glass
for Bakery Applications

www.hussmann.com

Hussmann Service Merchandiser with Straight Glass for Bakery Applications

SGB



Merchandising Capacity
This high volume service bakery case can hold up to 3 rows of shelves in a small width footprint.

Merchandising Visibility
Flat non-glare glass and built in air sweep assure the product looks great.



Remote Lengths: 48", 57 1/2", 75 1/2", and 96"
Non-Refrigerated Lengths: 48", 57 1/2", 75 1/2", and 96"
(Consult factory to request Sanitation Certification)

SGB Service Bakery Straight Glass

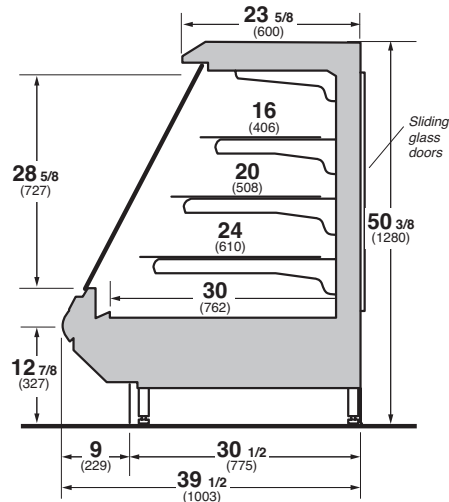

Plan View

SGB Plan View

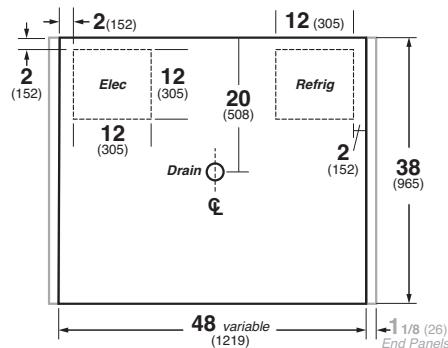

Features.

- Straight lift-up non-glare glass
- LED canopy lighting †
- 16", 20" and 24" LED lighted glass shelves †
- Thermostat
- White interior
- Rear sliding doors
- Please reference color chart for choice of standard Hussmann paint and finish options (www.hussmann.com)

Options.

- End panels (solid or view end)
- Mirror bright stainless steel on interior of end panels
- Black or stainless steel interior
- Custom lengths and options* (consult your Hussmann sales representative)

Additional Information.

- Self-Service Bakery Case: SHVSS
- Self-Service Low Temp Case: SFG/SGNG



Hussmann refrigerated merchandisers configured for sale for use in the United States meet or surpass the requirements of the DOE 2017 energy efficiency standards.

* Some optional features may need to be certified by UL, NSF, and/or other 3rd party certification agencies. Contact Hussmann for verification or questions for availability.

† Only lighting configurations that are compliant with the U.S. Dept. of Energy (DOE) 2017 regulation are available for sale for use in the U.S.A.

NOTE: These merchandisers are designed for use in stores when temperature and humidity do not exceed 75°F and 55% R.H. We reserve the right to change or revise specifications and product design in connection with any feature of our products. Such changes do not entitle the buyer to corresponding changes, improvements, additions, or replacements for equipment previously sold or shipped.

For additional resources, contact your representative or visit www.hussmann.com.



Note.
Use Hussmann's technical data sheets to get precise dimensions for all store layout purposes.

Intertek Intertek

HUSSMANN®

Hussmann Specialty
13770 Ramona Avenue
Chino, California 91710-5423
Ph: 800.395.9229

www.hussmann.com