



SIM



Self Service Island Mobile 4-Sided Viewable / Accessible Display



ADVANTAGES

- **Increase Impulse Buys**
Bring visibility and attention to promo items to increase sales anywhere in the store
- **Merchandising Flexibility**
Merchandise a wide variety of products like meat, deli, produce or bakery with optional risers and dividers
- **Ease of Ownership**
The easiest display to install, move, and maintain



KEY POINTS

- **Location Flexibility**
Plug & play design with casters and standard 115v plug allow you to feature products anywhere in the store



SIM Self Service Island Mobile 4-Sided Viewable/Accessible Display

Increase Impulse Sales

- Bring products into the aisles and get shopper attention
- 4-Sided visibility and accessibility to drive sales



Merchandising Flexibility

- Display a wide variety of products in unique formats
- Riser and divider accessories available for creative layouts and cross-selling



Merchandising Capacity

- Largest cubic display area to hold large products
- More units means less time replenishing the display

Ease of Ownership

- The easiest display from installation, to maintenance, to energy cost
- Save money on install costs with a standard 115V plug
- Tool free part removal for easy cleaning
- 48% less energy usage than similar competitor units

Merchandising Accessories

Display a wide variety of products in unique formats



Risers for Reduced Pack Out and Creative Displays

Dividers for Added Flexibility and Cross-Selling

Maximum Depth Maximum Capacity

Model	L	D	H	HP	Hz/Ph	Volts	Circuit Amps	Fuse Amps	NEMA plug	Refrig. Load (BTU/h)	A/C Load (BTU/h)	Shipping Weight - approx. (lbs)
SIM4AA	53-5/8"	40-1/2"	41-1/2"	1/2	60/1	115	9.5	15	5-15P	3600	4883	900

SCAN/CLICK FOR MORE INFO:
(In-store photos, Technical documents)



Size: 4' x 4' Island

FEATURES

- Crystal clear plexiglass upper display
- NSF Type I and II operating conditions
- Display area depth of 10 1/4"
- 4" Riser available accessories
- Optional 3" or 7" plastic divider available accessories
- Patented high efficiency louvers and airflow design
- High efficiency and low energy consumption of just 8.2 kWh/day
- Hussmann microSC utilizes R-290 (propane) refrigerant
- 2 Year Limited Warranty

OPTIONS

Bumper Type:

- No Bumper
- 1000 Series 1" Black Vinyl
- 3/4" Slim Square Stainless Tube

Leg Type:

- Recessed Locking Casters
- Leveler Legs



Movable Internal Dividers:

- 3" height black plastic divider QTY
- 7" height black plastic divider QTY

4" Riser Accessory:

- 4 Risers for a shallower case
- 2 Risers for stepped split-level
- 1 Riser for raised center area

Plug Types:

- Standard NEMA 5-15 P 
- Locking NEMA L5-15 P 

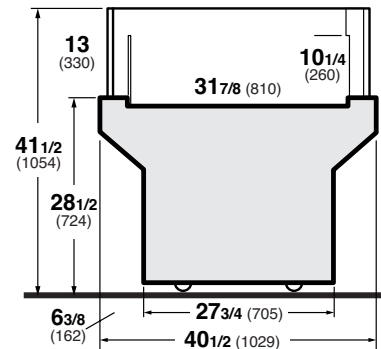

Hussmann refrigerated merchandisers configured for sale for use in the United States meet or surpass the requirements of the DOE 2017 energy efficiency standards.

NOTE: These merchandisers are designed for use in stores when temperature and humidity do not exceed 75F and 55% R.H. We reserve the right to change or revise specifications and product design in connection with any feature of our products. Such changes do not entitle the buyer to corresponding changes, improvements, additions, or replacements for equipment previously sold or shipped.



** Refrigeration load calculated at 20° F evaporation and 110° F condensing temperature.

HUSSMANN®

Hussmann Corporation
12999 St. Charles Rock Rd.
Bridgeton, MO 63044-2483
Ph: 800.592.2060

www.hussmann.com