

HUSSMANN®



Model shown with options.

SMB

Excel Service Merchandiser with
Curved Glass and Blower Coil for Meat and Deli

- NSF Certified

www.hussmann.com

Husmann Excel Service Merchandiser with Curved Glass and Blower Coil for Meat and Deli Applications

SMB - Single Pane Curved Glass Case with Blower Coil

Available in 8' and 12' lengths. Contact your sales rep for information on possible availability of additional case lengths.

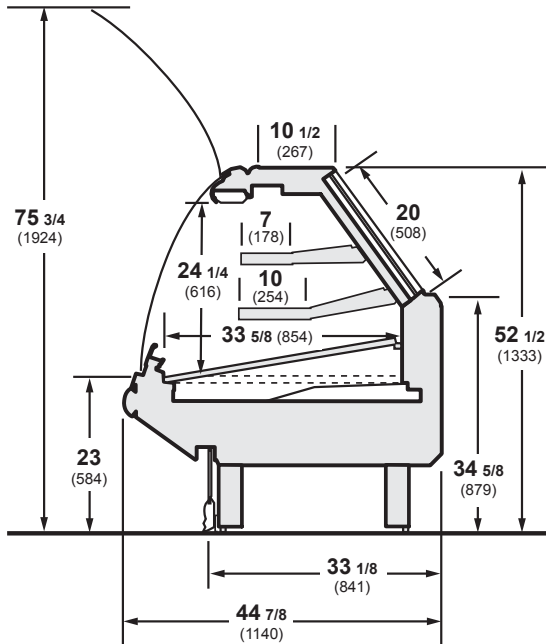

Plan View

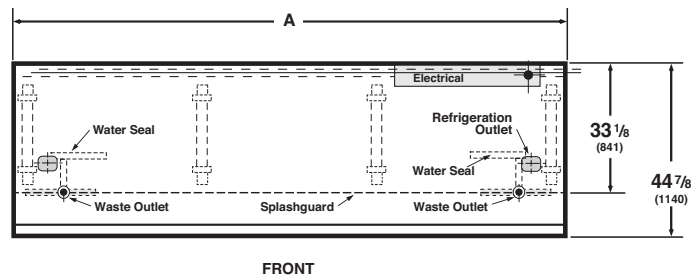

Dimensions	8 FT	12 FT
A	96 3/8 (2448)	144 1/2 (3670)

Notes:
Overall case length without ends or partitions. Contact your sales representative for information on possible availability of additional case lengths.

Note

Use Husmann's technical data sheets to get precise dimensions for all store layout purposes.

Advanced Design.

The SMB and related SM models incorporate advanced features and benefits, including modular coils, superior energy efficiency, modular case design, durable bumper, factory pre-adjusted expansion valves, and seamless polystyrene "bathtub" bottoms for quick, easy cleaning.

Reduced Refrigerant, Fewer Leaks.

Patented Husmann modular coils require 50% to 60% less refrigerant. Also, all return bend solder joints have been eliminated, which greatly reduces the possibility of refrigerant leaks.

Merchandising with Style.

One look tells the story. Sleeker, cleaner exterior to enhance product display. Attractive molded end design. Excellent lighting and product visibility for "high impact" merchandising that sells. Up to two lighted mezzanine shelves can be added to increase merchandising capacity. 30°, 45° and 90° inside and outside wedges available.

Easy to Work.

Front glass tilts up for easy stocking and cleaning. 10 1/2" stainless flat non-movable top is standard. A large 20" rear door opening has an increased angle to improve reach and ergonomics. Options include mezzanine shelves, display racks, scale stands, thermometers and wrapping boards.

NSF Certified.

The SMB has been NSF Certified to ANSI/NSF standard 7.

DOE 2017 Energy Efficiency Compliant Husmann refrigerated merchandisers configured for sale for use in the United States meet or surpass the requirements of the DOE 2017 energy efficiency standards.

NOTE: These merchandisers are designed for use in stores when temperature and humidity do not exceed 75°F and 55% R.H.

NOTE: We reserve the right to change or revise specifications and product design in connection with any feature of our products. Such changes do not entitle the buyer to corresponding changes, improvements, additions, or replacements for equipment previously sold or shipped.

For additional resources, contact your representative or visit www.husmann.com.

HUSSMANN®

Husmann Corporation
12999 St. Charles Rock Rd.
Bridgeton, MO 63044-2483
Ph: 314.291.2000

www.husmann.com