

**HUSSMANN®**

---



---

# SMGT

Excel Service Merchandiser with Tilt Up  
Straight Glass and Gravity Coil for Meat and Deli

- NSF Certified

---

[www.hussmann.com](http://www.hussmann.com)

# Husmann Excel Service Merchandiser with Tilt Up Straight Glass and Gravity Coil for Meat and Deli Applications

## SMGT - Tilt Up Straight Glass with Gravity Coil

Available in 8' and 12' lengths. Contact your sales rep for information on possible availability of additional case lengths.

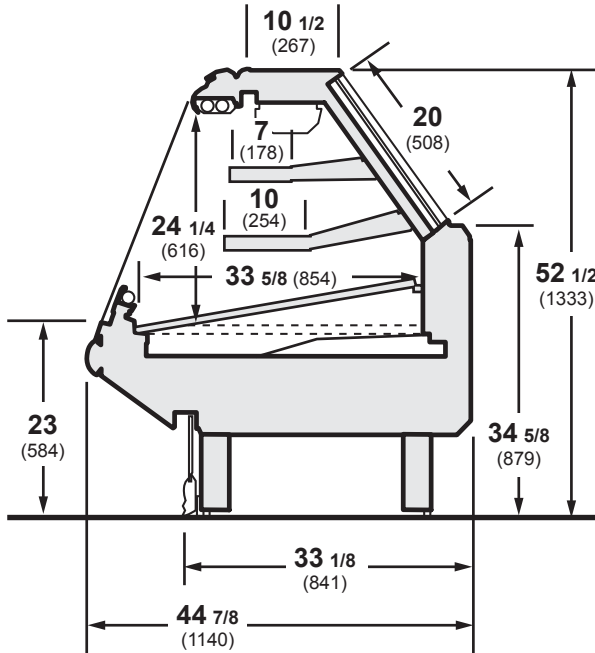

## Plan View

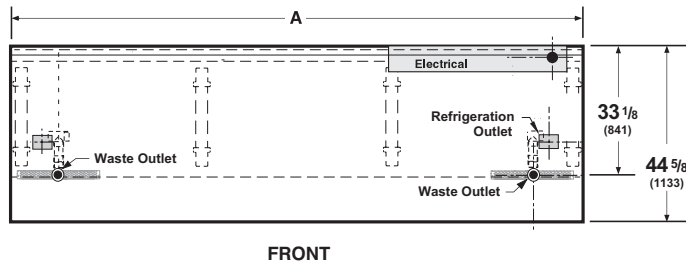

Dimensions	8 FT	12 FT
A	96 3/8 (2448)	144 1/2 (3670)

### Notes:

Overall case length without ends or partitions. Contact your sales representative for information on possible availability of additional case lengths.

### Note

Use Husmann's technical data sheets to get precise dimensions for all store layout purposes.

## Tilt Up Straight Glass.

Straight front glass tilts up for easy stocking and cleaning. 10" stainless flat non-movable top is standard. A large 20" rear door opening has an increased angle to improve reach and ergonomics.

## Advanced Design.

The SMGT incorporates advanced features and benefits, including modular coils, superior energy efficiency, modular case design, durable bumper, factory pre-adjusted expansion valves, and seamless polystyrene "bathtub" bottoms for quick, easy cleaning.

## Reduced Refrigerant, Fewer Leaks.

Patented Husmann modular coils require 50% to 60% less refrigerant. Also, all return bend solder joints have been eliminated, which greatly reduces the possibility of refrigerant leaks.

## Options.

Options include mezzanine shelves, scale stands, thermometers, wrapping boards, and non-glare glass.

## NSF Certified.

The SMGT has been NSF certified to ANSI/NSF standard 7.



Husmann refrigerated merchandisers configured for sale for use in the United States meet or surpass the requirements of the DOE 2017 energy efficiency standards.

NOTE: These merchandisers are designed for use in stores when temperature and humidity do not exceed 75°F and 55% R.H.

NOTE: We reserve the right to change or revise specifications and product design in connection with any feature of our products. Such changes do not entitle the buyer to corresponding changes, improvements, additions, or replacements for equipment previously sold or shipped.

For additional resources, contact your representative or visit [www.husmann.com](http://www.husmann.com).

**HUSMANN®**

**Husmann Corporation**  
12999 St. Charles Rock Rd.  
Bridgeton, MO 63044-2483  
Ph: 314.291.2000

[www.husmann.com](http://www.husmann.com)