

HUSSMANN®



SMGV

Excel Service Merchandiser with Straight Glass
and Gravity Coil for Meat and Deli

- NSF Certified

www.hussmann.com

Husmann Excel Service Merchandiser with Straight Glass and Gravity Coil for Meat and Deli Applications

SMGV - Straight Glass with Gravity Coil and Small Blower Coil

Available in 8' and 12' lengths. Contact your sales rep for information on possible availability of additional case lengths.

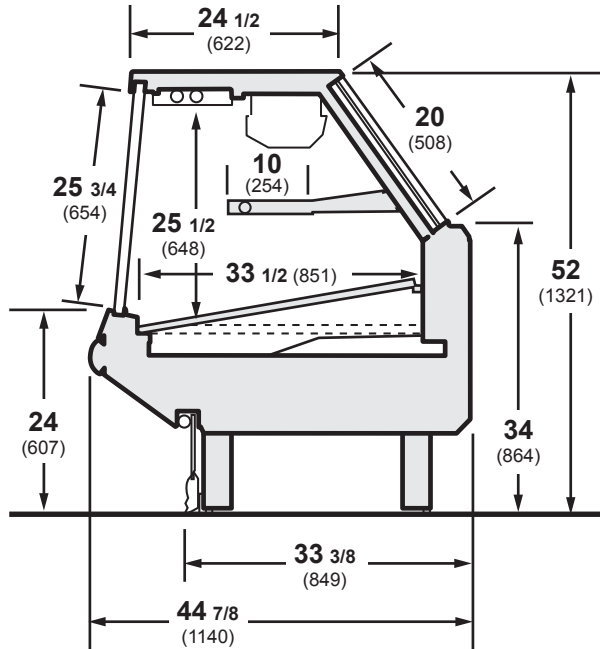

Plan View

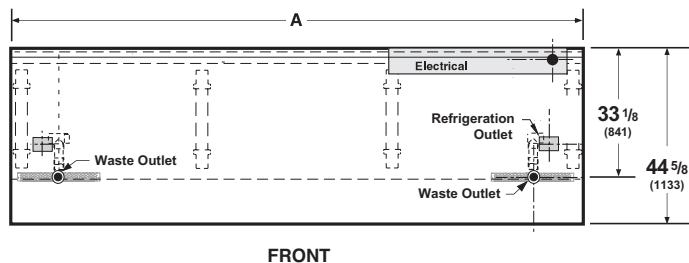

Dimensions	8 FT	12 FT
A	96 3/8 (2448)	144 1/2 (3670)

Notes:

Overall case length without ends or partitions. Contact your sales representative for information on possible availability of additional case lengths.

Note

Use Husmann's technical data sheets to get precise dimensions for all store layout purposes.

Straight Glass with Large, Stainless Steel Top Display Surface.

The SMGV offers a traditional straight glass design with a large, stainless steel display surface on top. This provides plenty of extra room for customer service and/or for displaying signs or related products.

Advanced Design.

The SMGV incorporates advanced features and benefits, including modular coils, superior energy efficiency, modular case design, durable bumper, and factory pre-adjusted expansion valves.

Reduced Refrigerant, Fewer Leaks.

Patented Husmann modular coils require 50% to 60% less refrigerant. Also, all return bend solder joints have been eliminated, which greatly reduces the possibility of refrigerant leaks.

Options.

Options include third row canopy lights, mezzanine shelves, scale stands, thermometers and wrapping boards.

NSF Certified.

The SMGV has been NSF certified to ANSI/NSF standard 7.

DOE 2017 Energy Efficiency Compliant Husmann refrigerated merchandisers configured for sale for use in the United States meet or surpass the requirements of the DOE 2017 energy efficiency standards.

NOTE: These merchandisers are designed for use in stores when temperature and humidity do not exceed 75°F and 55% R.H.

NOTE: We reserve the right to change or revise specifications and product design in connection with any feature of our products. Such changes do not entitle the buyer to corresponding changes, improvements, additions, or replacements for equipment previously sold or shipped.

For additional resources, contact your representative or visit www.husmann.com.

HUSMANN®

Husmann Corporation
12999 St. Charles Rock Rd.
Bridgeton, MO 63044-2483
Ph: 314.291.2000

www.husmann.com