

HUSSMANN®

Specialty



Entyce Family

TY4-5

4 Levels • 5' Width

Self-Service Shop Around Island Merchandiser
Deli, Dairy, Sandwiches, Cheese, Grab-n-Go, Beverage, Produce

Entyce *Your Shoppers*

www.hussmann.com

Hussmann Self-Service Shop Around Island Merchandiser Deli, Dairy, Sandwiches, Cheese, Grab-n-Go, Beverage, Produce

TY4-5



Exceptional merchandising
with open, cascading product presentation.

Entyce your Shopper

Designed to guide your shopper around to see everything and inspire impulse buying.

EcoShine II Plus LEDs (Standard)

- Saves 66% energy over T8s
- 85+ CRI for bringing out natural colors
- Diffused lighting eliminates pixilation and hot spots on product packaging



More Pack-Out

High pack out in small footprint.

Island Merchandisers

Remote - 7' (TY4-5X-7I-R), **9'** (TY4-5X-9I-R), **11'** (TY4-5X-11I-R), **13'** (TY4-5X-13I-R), **15'** (TY4-5X-15I-R), **17'** (TY4-5X-17I-R)

TY4-5 Entyce 4 level 5' wide island

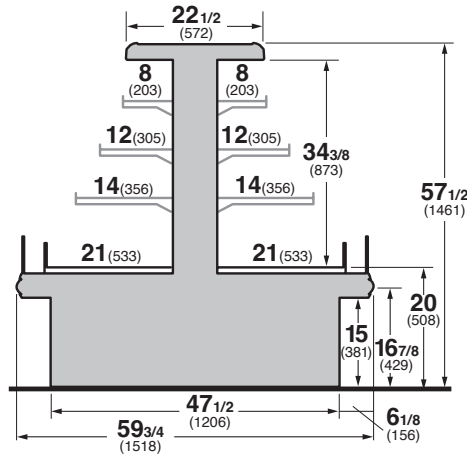

TY3-5, TY4-5 5' wide Island Merchandiser

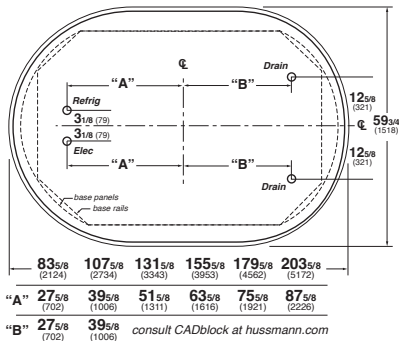

Entyce Family

Flexible layouts to meet your store planning needs with multiple levels, widths, lengths, and styles

Entyce	PRODUCT LEVELS	FOOTPRINT	SHAPE
has a solution for you.			



Product Temp Enhancement

Developed for more stringent ambient conditions - Balanced air distribution and advanced coil technology.



New Adjustable Shelving System

Merchandising flexibility with vertical shelf height adjustments.

Features.

- painted exterior
- radius perimeter
- LED EcoShine II canopy lighting
- black metal deck and back wall,
- 2" black vinyl cart bumper
- energy efficient fan motors.
- dual forced air refrigeration coils
- Hussmann colors
- DOE and ETL approved, and FDA compliant
- Please reference Color Chart for choice of standard Hussmann paint and finish options (www.hussmann.com)

Options.

- optional base heights
- special stainless steel tube bumper
- 8", 10", 12", 14" shelves
- LED shelf lighting
- solid surface top inlay
- stainless or white interior
- liquid line shut-off valve
- custom lengths and options* (consult your Hussmann sales representative)



Hussmann refrigerated merchandisers configured for sale for use in the United States meet or surpass the requirements of the DOE 2017 energy efficiency standards.

* Some optional features may need to be certified by UL, NSF, and/or other 3rd party certification agencies. Contact Hussmann for verification or questions for availability.

NOTE: These merchandisers are designed for use in stores when temperature and humidity do not exceed 75°F and 55% R.H. We reserve the right to change or revise specifications and product design in connection with any feature of our products. Such changes do not entitle the buyer to corresponding changes, improvements, additions, or replacements for equipment previously sold or shipped.

For additional resources, contact your representative or visit www.hussmann.com.



Intertek

Intertek

Note.
Use Hussmann's technical data sheets to get precise dimensions for all store layout purposes.

HUSSMANN®

Hussmann Specialty
13770 Ramona Avenue
Chino, California 91710-5423
Ph: 1-800.395.9229

www.hussmann.com