

PARTS LIST

Item	Quantity		Description
	Wall	Island	
1.	1	1	Gasket 1/2 x 1/2 x 120
2.	1	0	Gasket 1/2 x 15/8 x 180
3.	4	5	Cap Screw 5/16 -18 x 1 1/4
4.	5	7	Flat Washer 5/16
5.	4	5	Lock Washer 5/16
6.	1	2	Hex Nut 5/16 -18
7.	1	1	Silicone
8.	1	4	Butyl Tape
9.	1	2	Splashguard Joint Support
10.	4	8	Screw, Hex Head SM #8 x 1/2

Note: Nut retainers are factory installed in the left end, and alignment pins are factory installed in the right end of merchandiser.

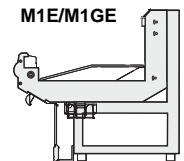
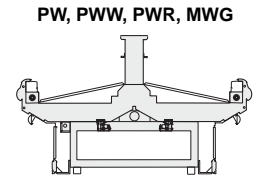

NOTE: Be sure merchandisers have been leveled according to the installation instructions to assure good fit and finish of the lineup. Be sure factory-installed nut retainers and alignment pins are in place.

- 1 Remove shelves (if installed), display racks, pans, front shelf supports and front air grilles from the right end as shown in Figure 1.

Remove and discard shipping braces and associated hardware.

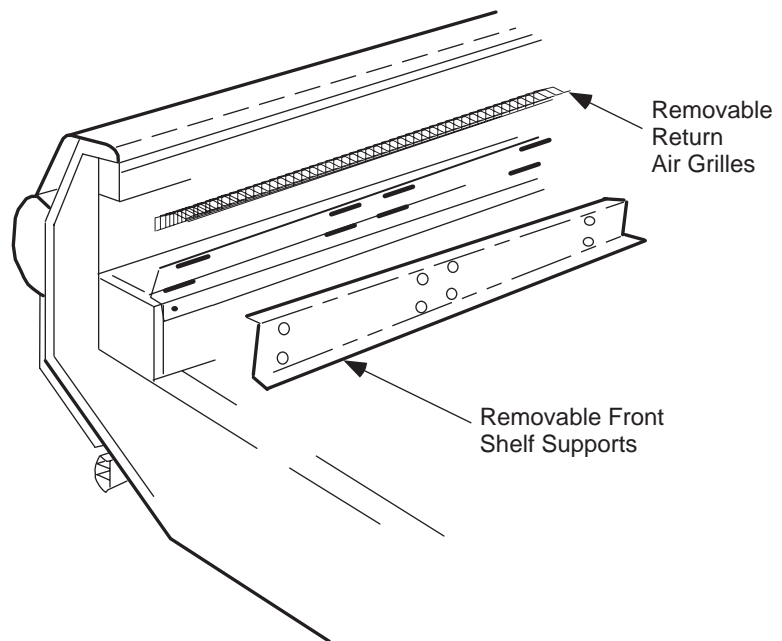

Figure 1. Removing Shelf Supports and Return Air Grilles

P/N 0376452D
January, 2003

Wall Case: Use a narrow ($\frac{3}{32}$ or smaller) rod to lift the honeycomb and remove it from its retainer as shown in Figure 2.

Remove the back panel from the right end by lifting up from its bottom edge and out. Do not use sharp tools.

Island Case: Use a small screwdriver to lift and remove the discharge grilles from both sides of center flue as shown in Figure 3.

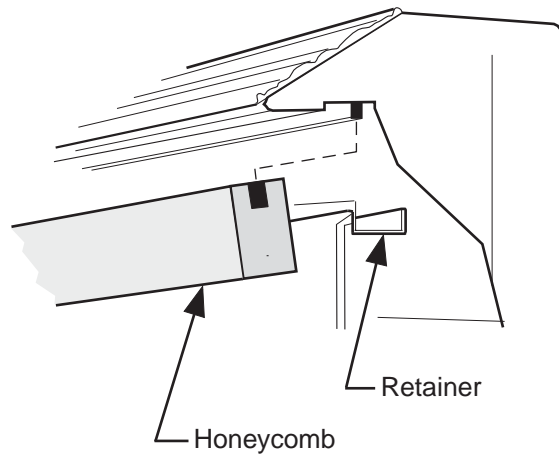

Figure 2. Removing Honeycomb

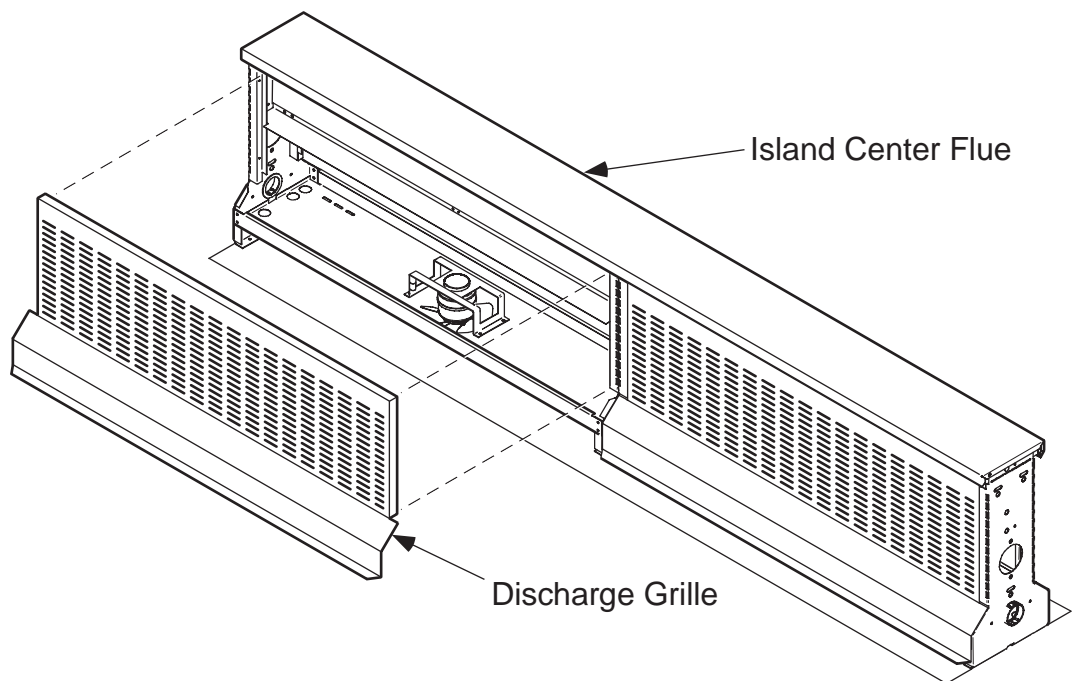
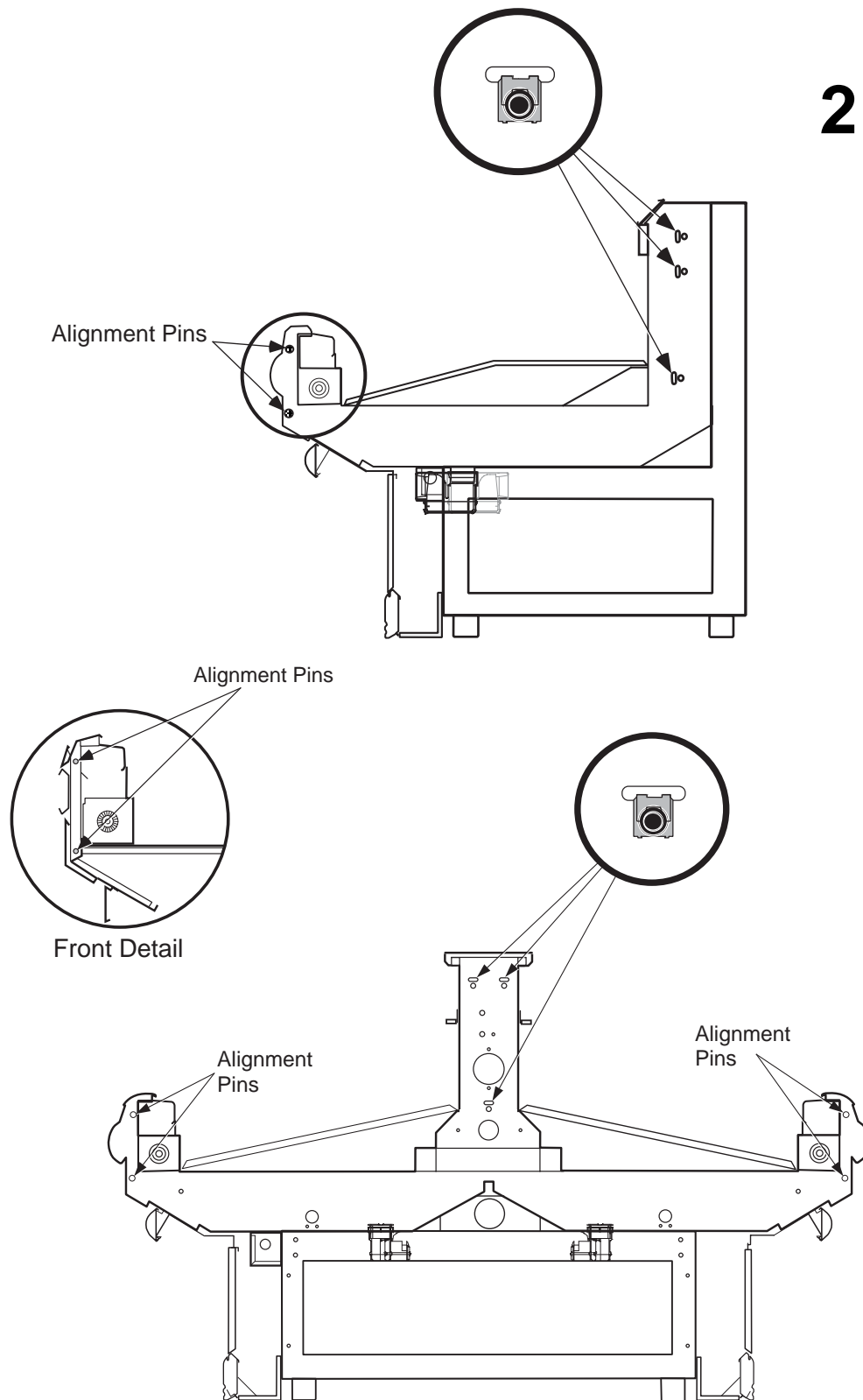

Figure 3. Removing Discharge Grilles



2 Verify that nut retainers and alignment pins are installed in the right-hand end of the left merchandiser in the locations shown in Figure 4.

Figure 4. Retainer and Alignment Pin Locations

3 Apply **Gasket – 1** in the horizontal recess across the bottom and up front to **cover slots**, including glass front (if applicable). Apply **Gasket – 2** to **cover foam-to-metal gap** at rear and across top as shown in Figure 5.

- Lap gaskets at lower corners.
- Check that there are no gaps between gasket and merchandiser.
- Do not stretch gasket, especially around corners.
- Do not butt gaskets; always lap joints.
- Remove paper backing after gasket is applied.

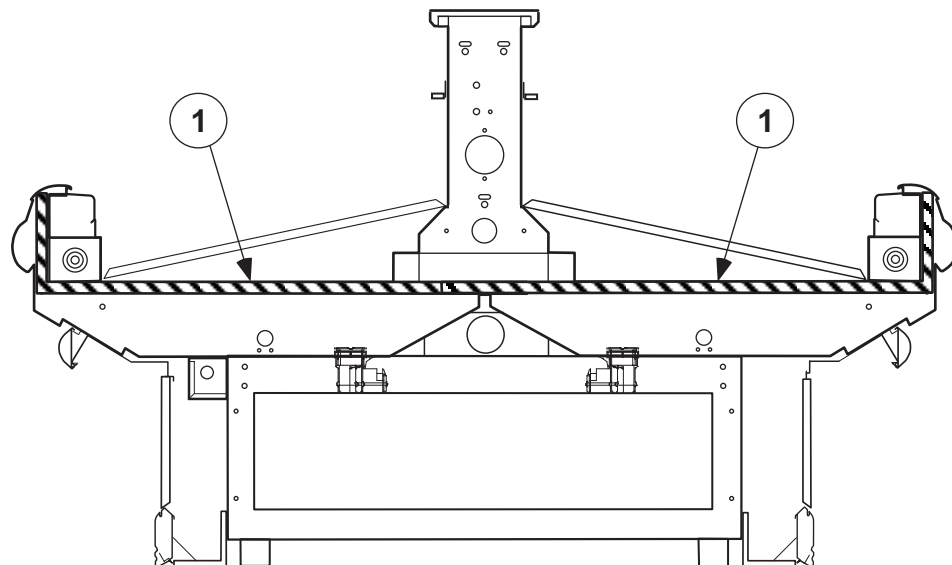
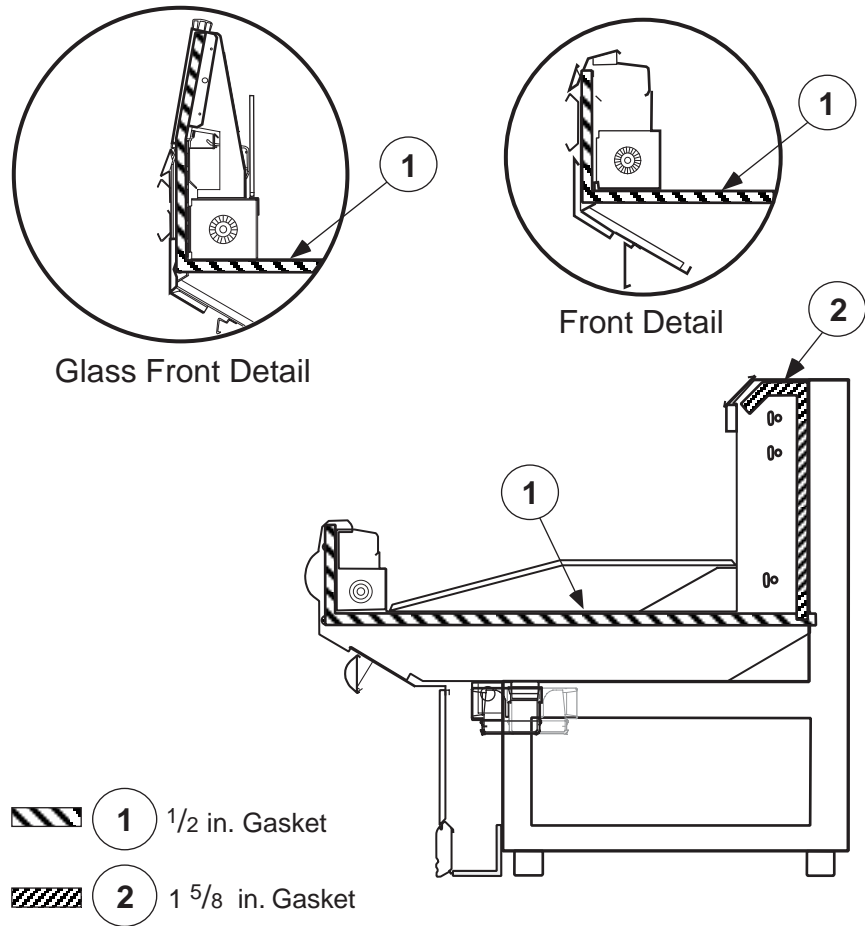

Figure 5. Installing Gaskets/Silicone

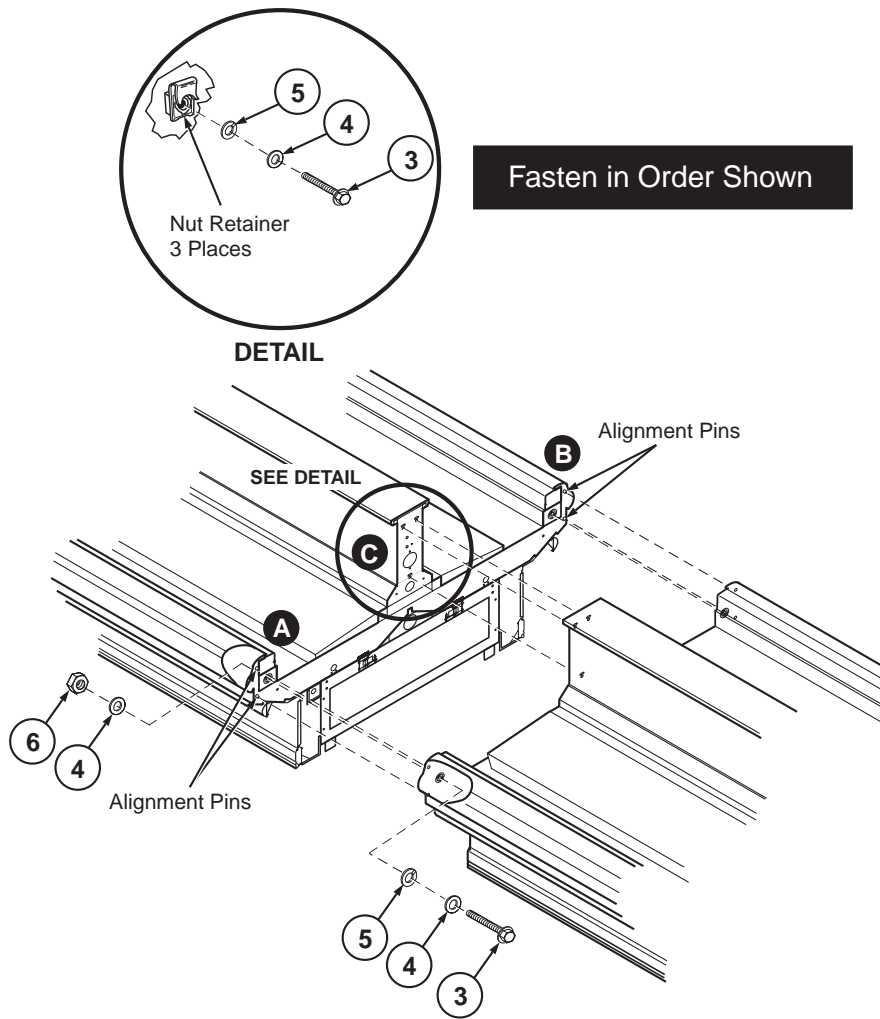

Figure 6. Joining Island Cases

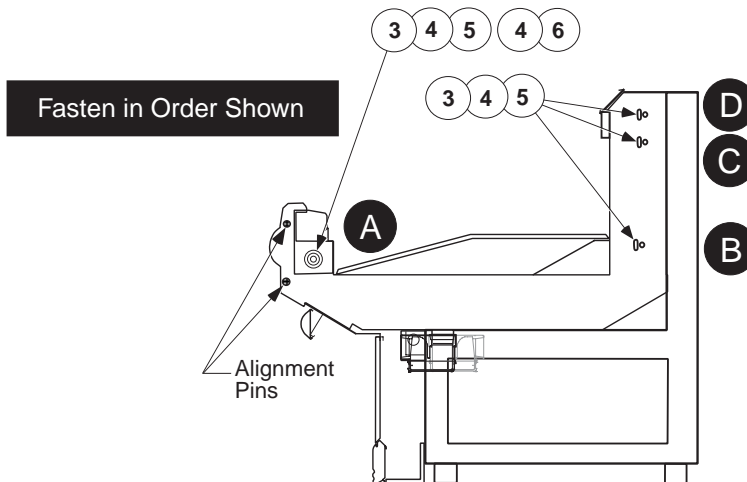

Figure 7. Joining Wall Cases

4 Move second Merchandiser against first, mating alignment pins with corresponding holes. Always push merchandisers together, *do not pull together*.

Using the front support bracket holes, fasten fronts together using

Cap Screw – 3,
Flat Washers – 4,
Lock Washers – 5, and
Hex Nut – 6.

Tighten only until front panels touch. Do not tighten fully.

Island Case: Use **Cap Screws – 3** with **Flat Washers – 4** and **Lock Washers – 5** to draw merchandisers together using nut retainers at center flue as shown in Figure 6. Tighten until gaskets are compressed.

Wall Case: Use **Cap Screws – 3** with **Flat Washers – 4** and **Lock Washers – 5** to draw merchandisers together using nut retainers at rear as shown in Figure 7. Start at the bottom, below the coil baffle, working your way up to the top; tighten until gaskets are compressed.

5 Apply **Silicone – 7** to area across front support brackets and down, stopping at bottom joint, as shown in the Front Details in Figure 8.

Apply **Butyl Tape – 8** across bottom joint, as shown in Figures 8 and 9.

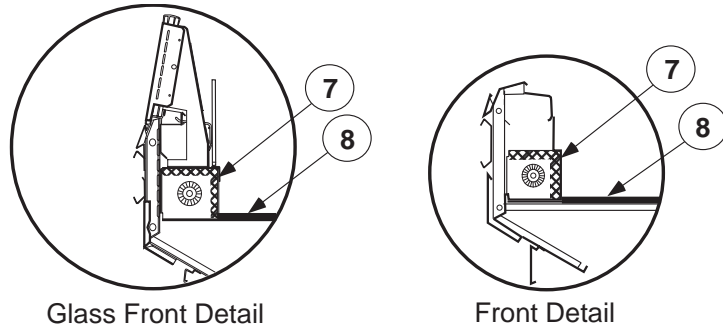

Glass Front Detail

Front Detail

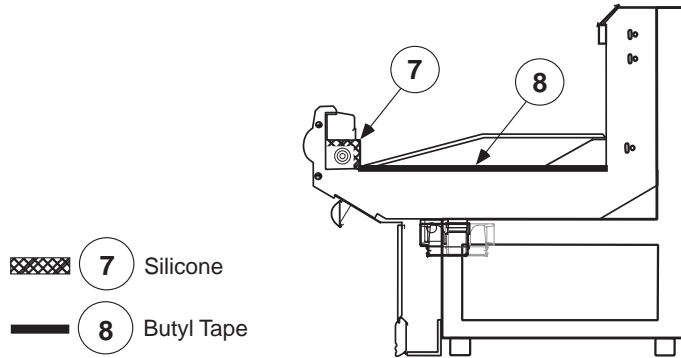

-  7 Silicone
-  8 Butyl Tape

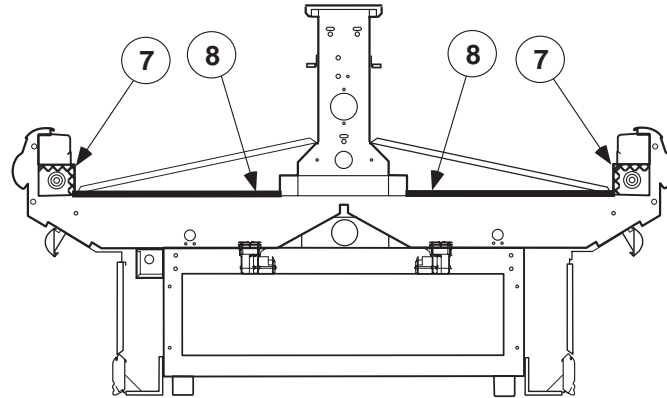

Figure 8. Applying Silicone

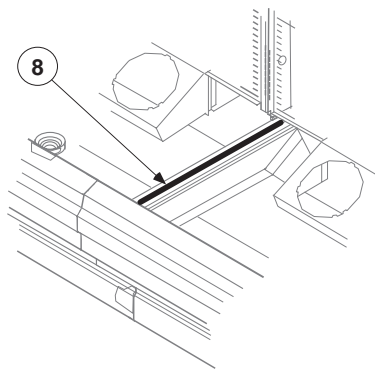

Figure 9. Applying Butyl Tape

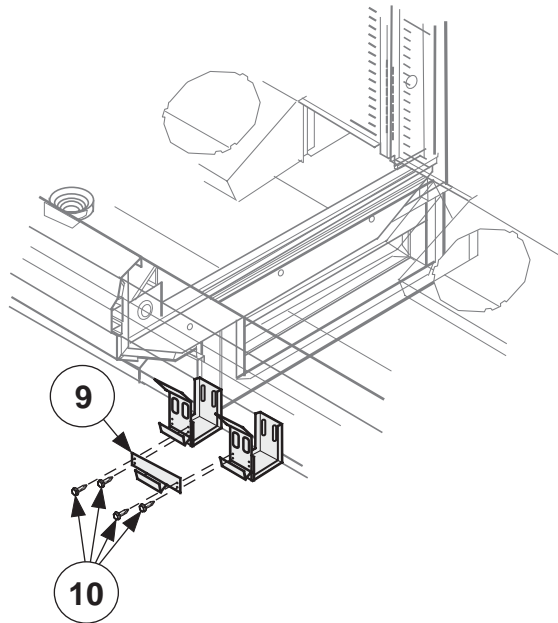

Figure 9. Installing Splashguard Joint Support

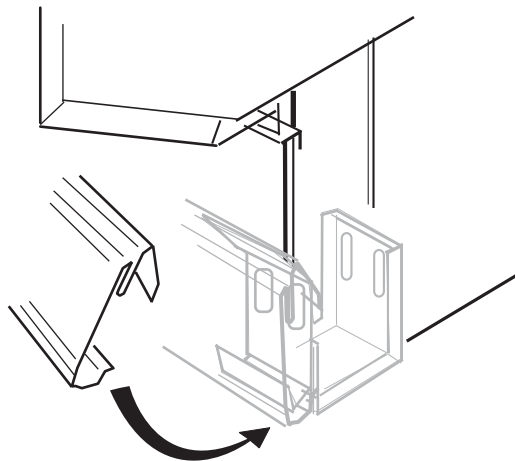

Figure 10. Installing Splashguard

6 Refer to Installation & Operations manual to install splashguard brackets.

Install **Splashguard Joint Support – 9** using **Screws – 10**. Install splashguards and lower front panels according to Installation & Operations manual and shown in Figure 9. Install Splashguard as shown in Figure 10.

7 Refer to Installation & Operations manual 0378414 to remove/install and offset top rail and bumpers.