

# HUSSMANN® **IMPACT™**

*Meat, Produce & Dairy*

*Single Deck  
& Multi-Deck  
Contour End Kit*

## Parts List

Item	Quantity		Description
	Single Deck	Multi Deck	
1.	2	4	Nut Retainers ( <b>RIGHT ENDS ONLY</b> )
2.	1	1	Gasket 1/2 x 1/2 x 120
3.	1	1	Gasket 1 5/8 x 1/2 x 180
4.	1	1	End Assembly
5.	3	5	Cap Screw 5/16-18 x 1 1/4
6.	3	5	Flat Washer 5/16
7.	1	1	Split Lockwasher 5/16
8.	1	1	Hex Nut 5/16-18
9.	3	5	Plug Button
10.	12	12	Phillips Head Sheet Metal Screw #8 x 1/2
11.	2	2	End Splashguard Retainer Assembly
12.	1	1	End Splashguard Assembly
13.	1	1	Lower End Panel
14.	2	2	Internal Bumper Joint Trim ( <b>LEFT ENDS ONLY</b> )
15.	1	1	Upper Bumper Starter ( <b>LEFT ENDS ONLY</b> )
16.	1	1	Lower Bumper Starter ( <b>LEFT ENDS ONLY</b> )
17.	1	1	Top Rail Starter ( <b>LEFT ENDS ONLY</b> )

## Optional End Bumper

18.	1	1	End Bumper Retainer
19.	6	6	Hex Head Sheet Metal Screw #10-16 x 3/4
20.	2	2	Bumper End Cap
21.	1	1	End bumper

Note: Nut retainers are factory installed in the left end, and alignment pins are factory installed in the right end of each merchandiser.

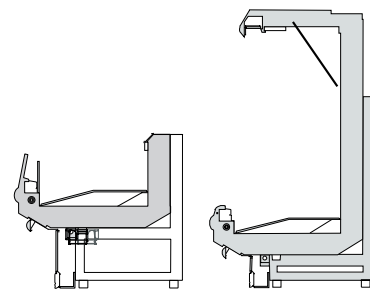

*P/N 376454C  
November, 1998*

**1** Remove shelves (if installed), display racks, pans, front shelf supports and front air grilles from the right end.

**Multideck Case:** Remove the rear panels at the end:

A. Remove the lower back panel first by lifting up from its bottom edge and out. Do not use sharp tools.

B. Lift the upper back panel up and out.

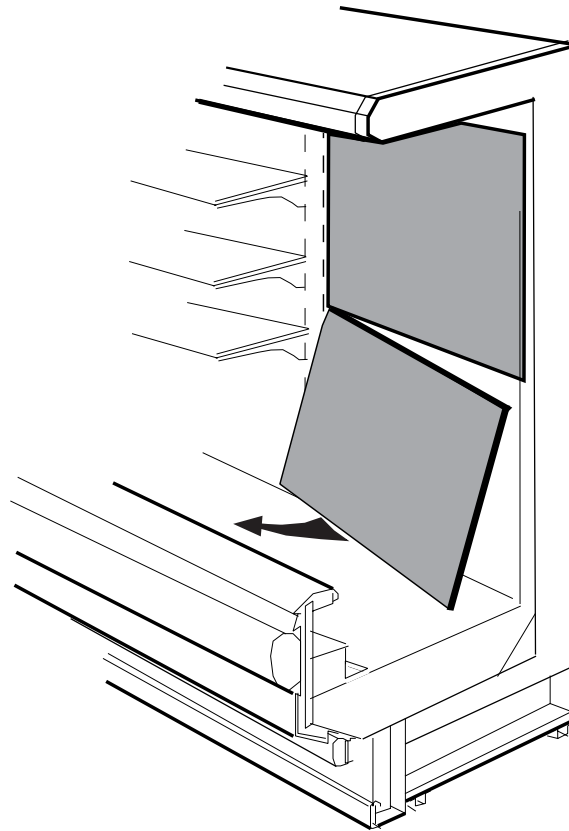

Removing Back Panels

**Single Deck Meat Case:** Use a narrow ( $\frac{3}{32}$  or smaller) rod to lift the honeycomb and remove it from its retainer.

**Single Deck Produce Case:** Use a small screwdriver to lift and remove the discharge grille.

Remove the back panel from the right end by lifting up from its bottom edge and out. Do not use sharp tools.

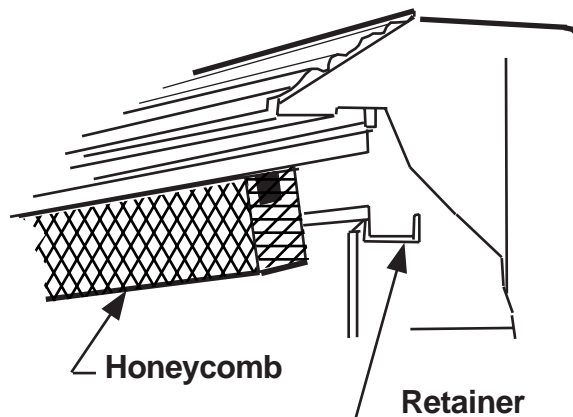

Removing Honeycomb

## Left End Only

**2** Remove factory installed top rails and bumpers from cases:

- a. To remove top rails, push rail toward the back of the case with one hand while lifting the top edge off the light channel with the other hand. See drawing below.
- b. Starting at one end, carefully peel bottom of top rail free of color panel and set the rail inside the case.
- c. Remove upper and lower bumpers by pulling bumper away from bumper retainers. Be careful not to lose the internal joint trims on the upper bumpers.

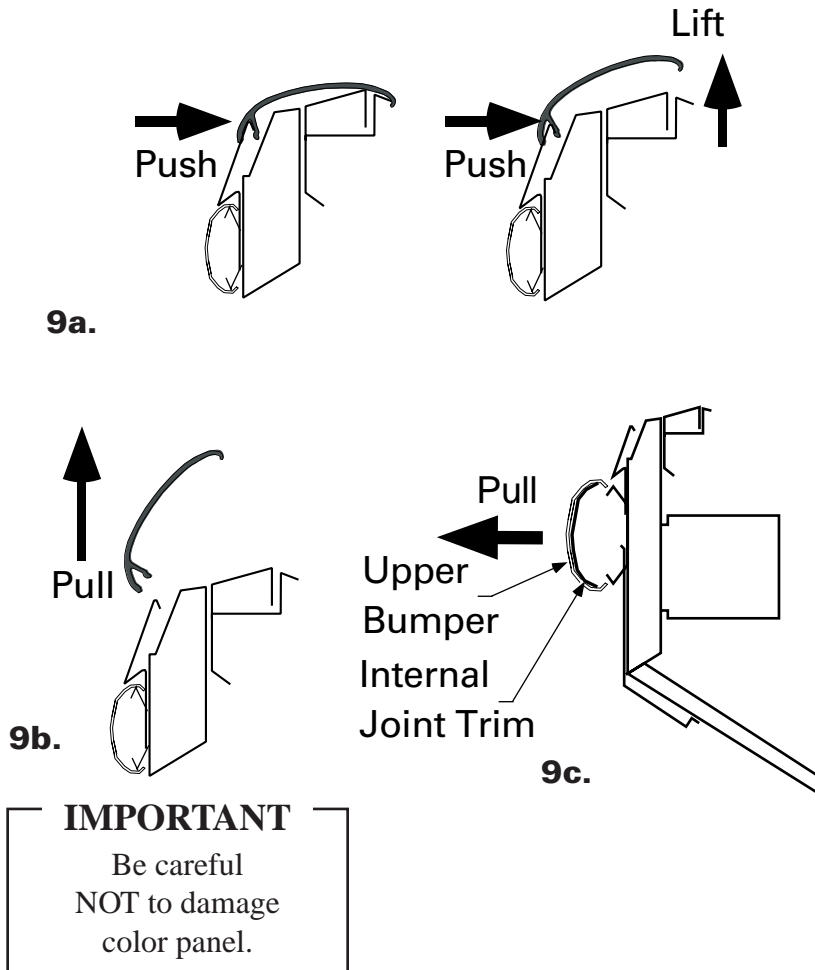

Removing Installed Top Rail and Bumpers

## Right End Only

- 3** Install **Nut Retainers - 1** into right end of merchandiser at locations shown. Check that factory-installed alignment pins are in place.

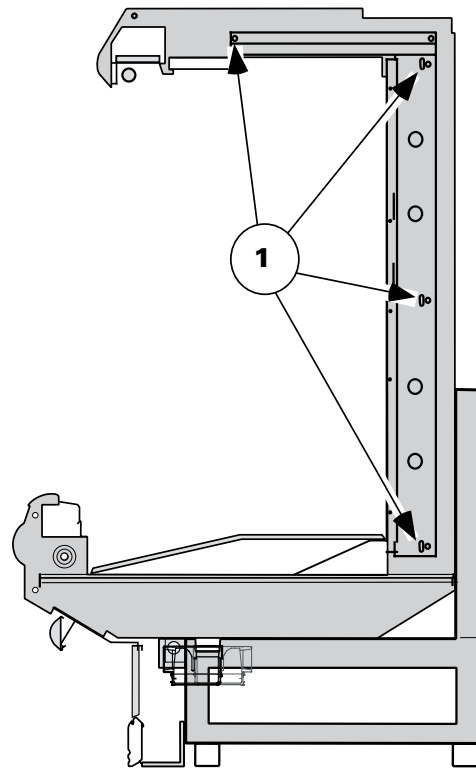

Installing Nut Retainers – Multideck

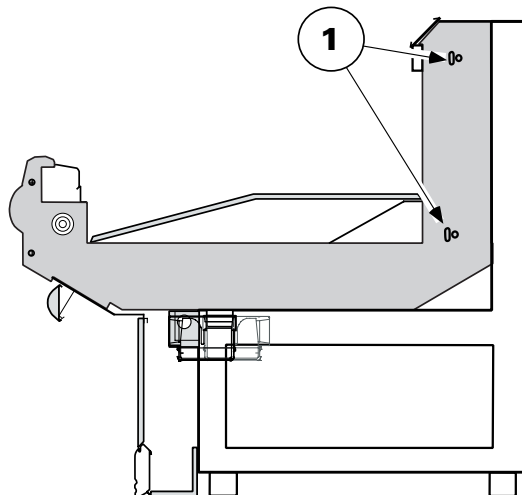

Installing Nut Retainers – Single Deck

Single Deck & Multideck  
Meat, Produce, & Dairy  
Contour End Kit

P/N 376454C

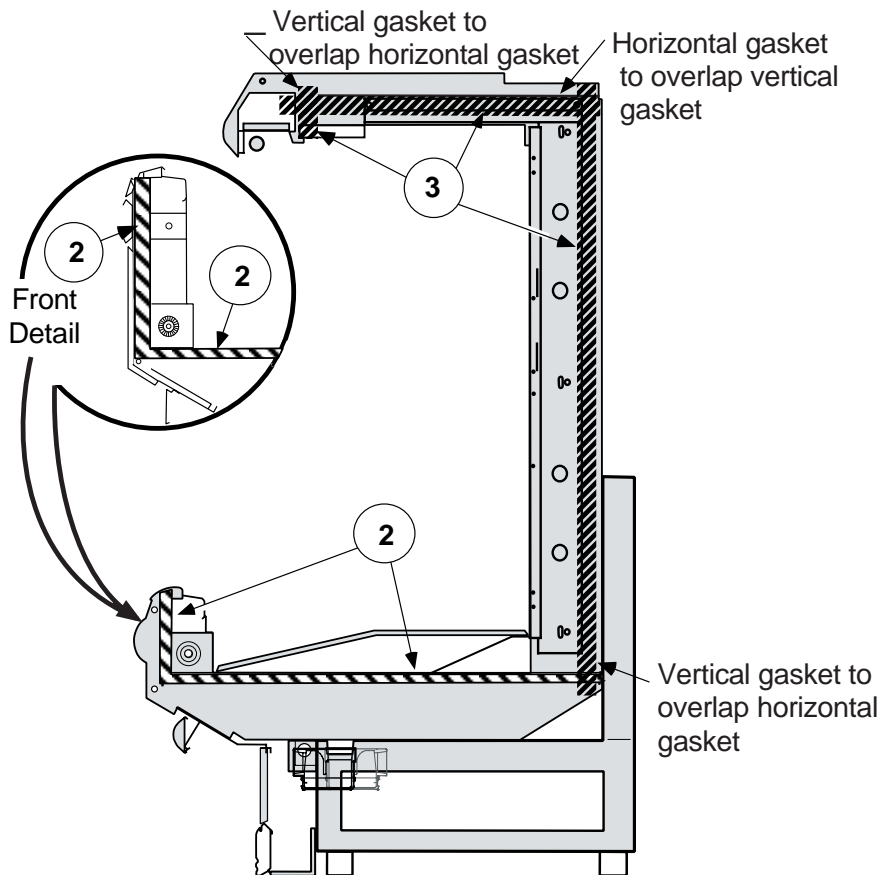

Applying Gaskets – Multideck

**4** Apply **Gasket – 2** in the horizontal recess across the bottom and up front, including glass front. Bend the gasket to cover the slots in the verticle brace.

Apply **Gasket – 3** to cover *foam-to-metal gap* at rear and across top. Lap gaskets at corners as shown. Check that there are no gaps between gasket and merchandiser.

- Do not stretch gasket, especially around corners.
- Do not butt gaskets; always overlap joints.
- Remove paper backing after gasket is applied.

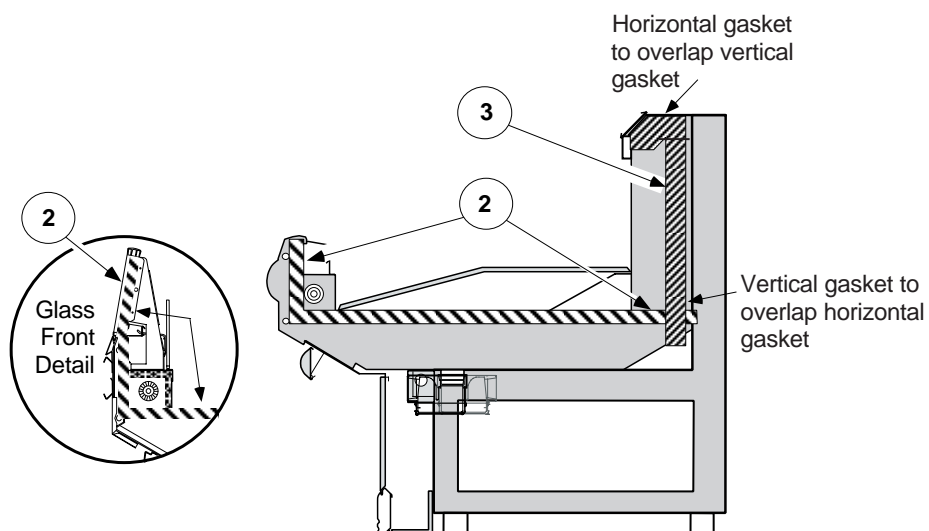

Applying Gaskets – Single Deck

**5** Fasten **End Assembly - 4** to merchandiser using **Cap Screws - 5** and **Washers - 6**.

Use **Lockwasher - 7** with **Hex Nut - 8** nut to secure front cap screw and washer.

After end assembly has been tightened, insert **Plug Buttons - 9**.

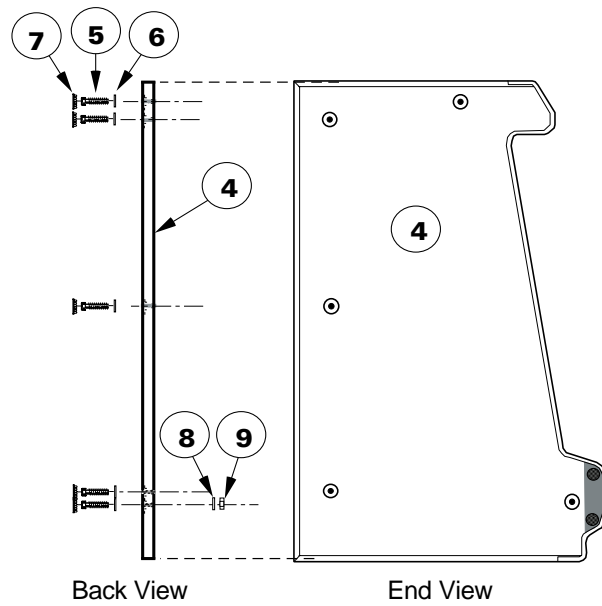

Installing Multideck Painted End (Low Front)

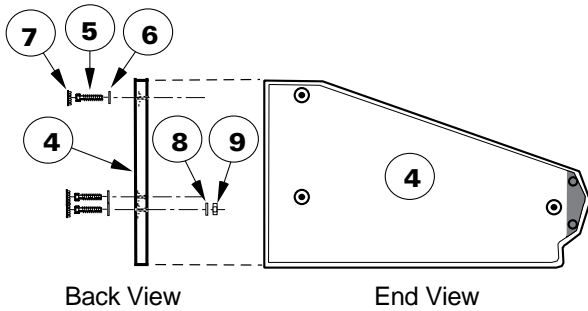

Installing Single Deck Painted End

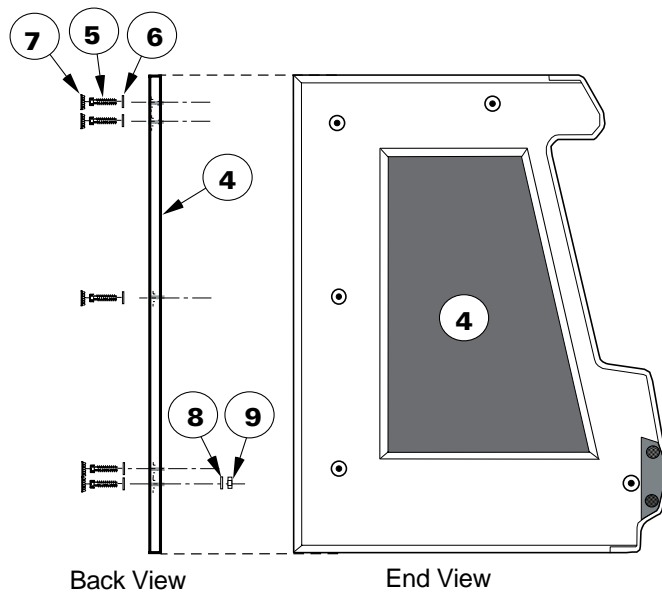

Installing Multideck Mirror End (High Front)

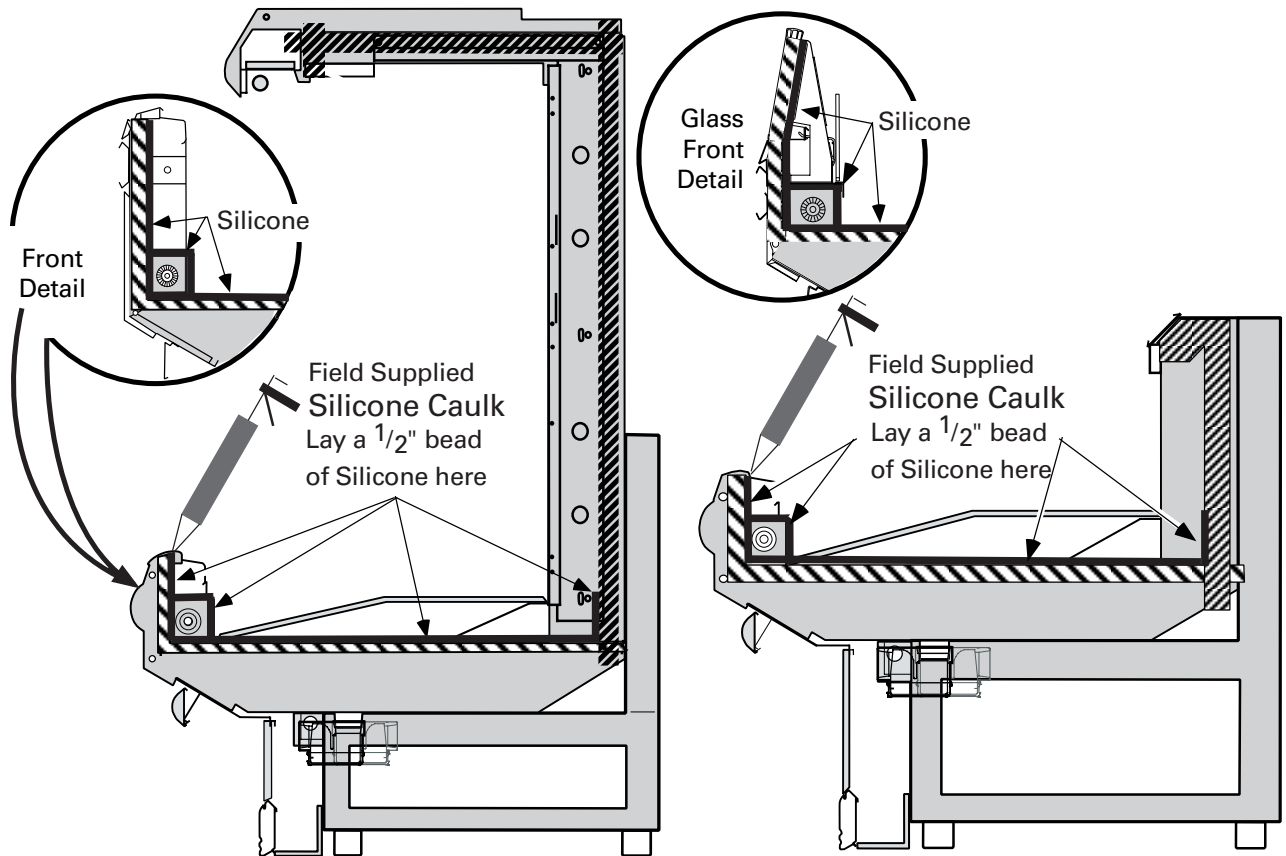

Applying Silicone

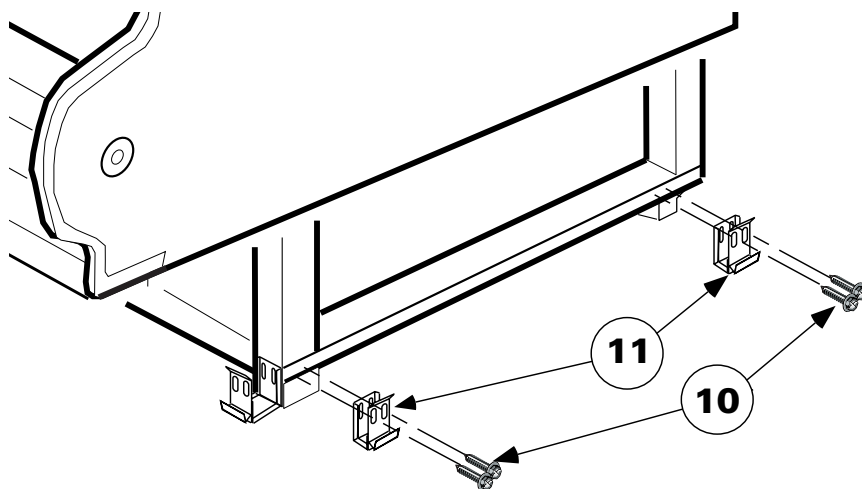

Installing End Splashguard Retainers

**6** Apply a  $\frac{1}{2}$ " bead of **Silicone** at the back starting at the first slot. Continue over the top of the gasket and up to the glass, as shown in drawings on this page. Use field-supplied silicone in any gap between front support bracket and end assembly.

**7** Use **Screw - 10** to attach **End Splashguard Retainer Assemblies - 11** to end frame. Retainer assemblies should rest on floor.

**8** Hook **End Splashguard Assembly - 12** under retainers and snap top into place.

Fasten to front splashguard retainer assembly using **Screw - 10**.

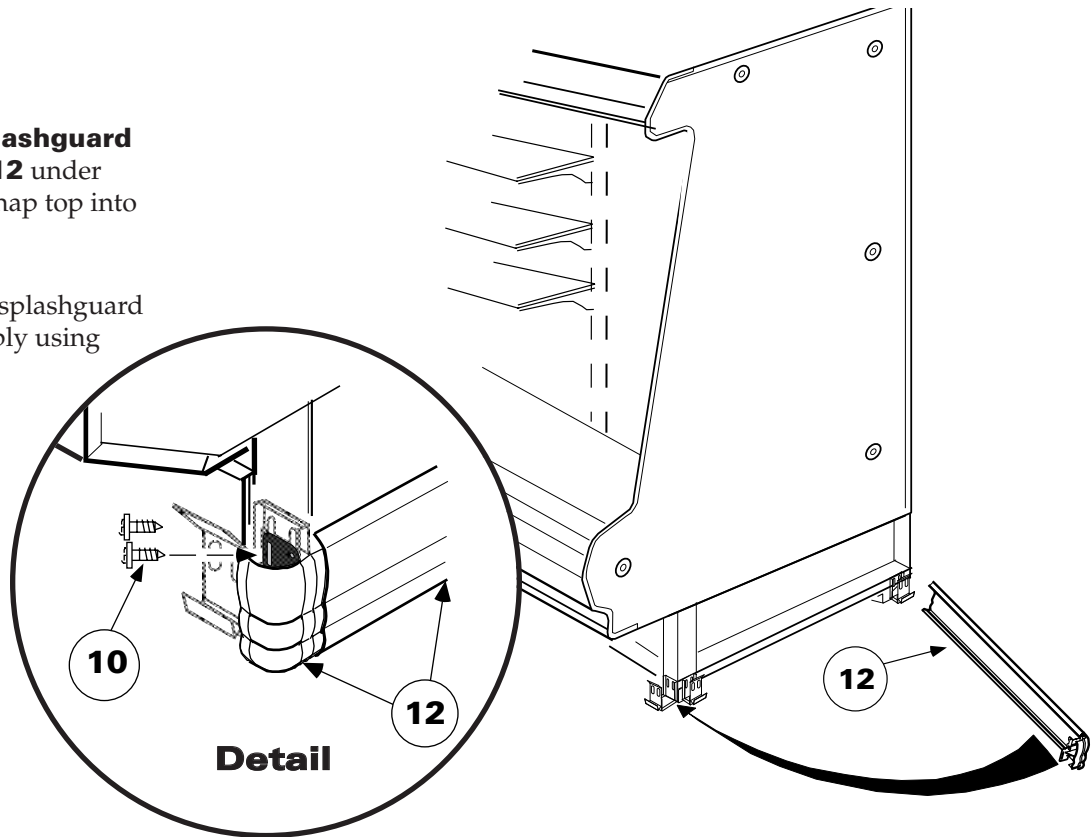

Installing End Splashguard Assembly

**9** Angle the **Lower End Panel - 13** up under the end assembly; then slip the lower edge into groove at top of splashguard. Panel front edge should be flush with lower front panel.

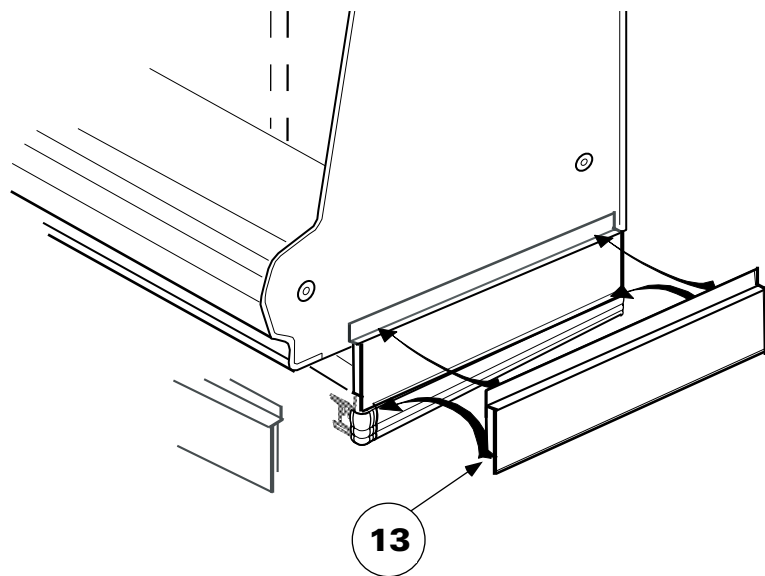

Installing Lower End Panel



## Left End Only

**10** Locate 2-foot starter bumpers and top rail; they are shipped with the left-end kit.

Starting at the left end of the line up, install the upper bumper starter section first:

Working left to right, position one **Internal Bumper Joint Trim - 14** over upper bumper retainer, butted against left end. Snap **Upper Bumper Starter - 15** over trim and push against end assembly.

Position second internal bumper trim under right end of starter.

Install full-length bumpers and internal trims offset across joints, making sure no gaps exist between sections. Hook bumpers at bottom and snap in place at top.

Do NOT install the last upper bumper section at this time. This section will be installed in the last step.

Install **Lower Bumper Starter - 16** butted up to left end. Install full-length lower bumpers offset across joint, making sure no gaps exist between sections. Simply push into place. There are no internal joint trims on the lower bumpers.

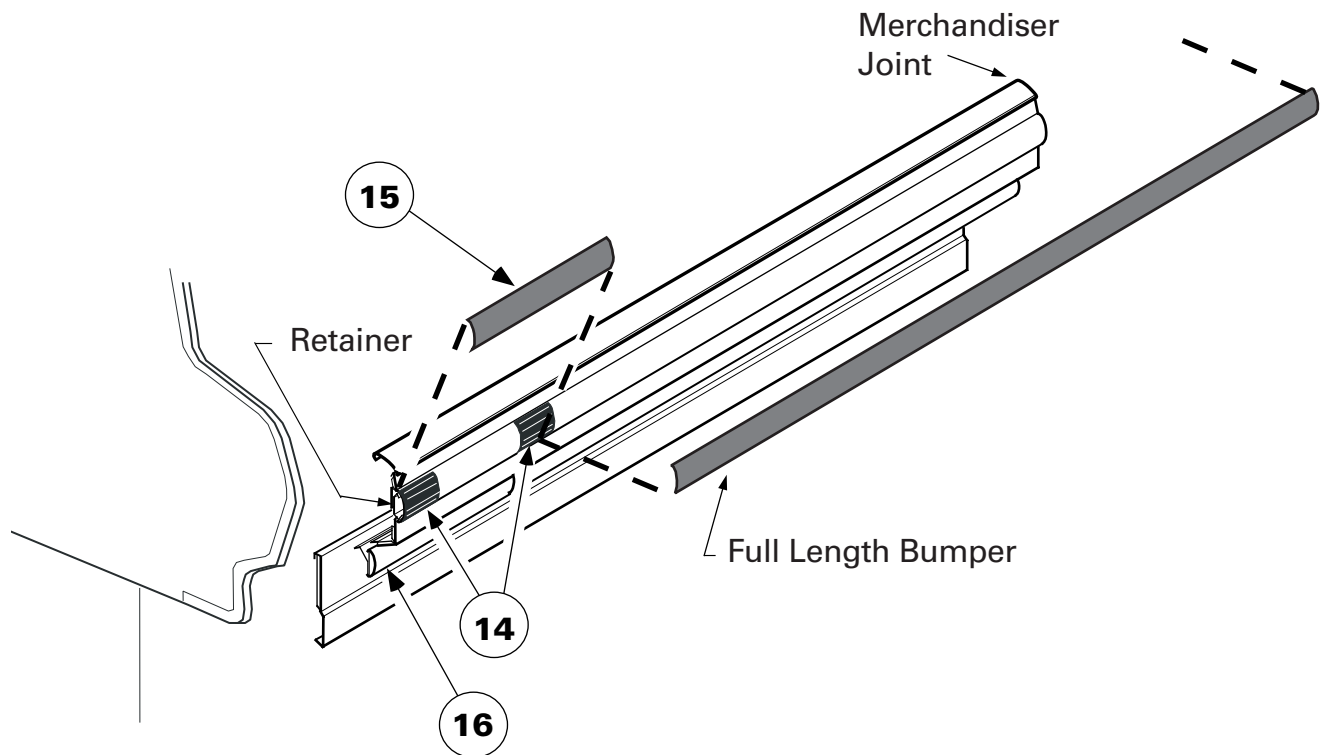

Installing Internal Bumper Joint Trim, and  
Upper and Lower Bumper Starters

## Left End Only

**11** Return to the left end of the line up

Position the **Top Rail Starter - 17** as shown.

**CAUTION:** The top rail should not be installed until the upper bumper is securely in place.

Push the bottom portion of the short top rail section down over the color panel. It helps if you lift the top with your other hand as shown. You will hear and feel the trim "snap" into place.  
**NOTE:** The trim must "snap" to be properly positioned.

Use one hand to push the top rail toward the rear of the case while using the other hand to "snap" the top section down over the edge of the light channel as shown. Again, **be sure it "snaps"** into place.

Install full length top rail flush with starter and offset across joint using the same procedures. Continue installing the top rails the length of the line up. **Do NOT install last section at this time.**

**CAUTION**  
Install the upper bumper before the top rail to prevent damage to the fasteners in the color panel.

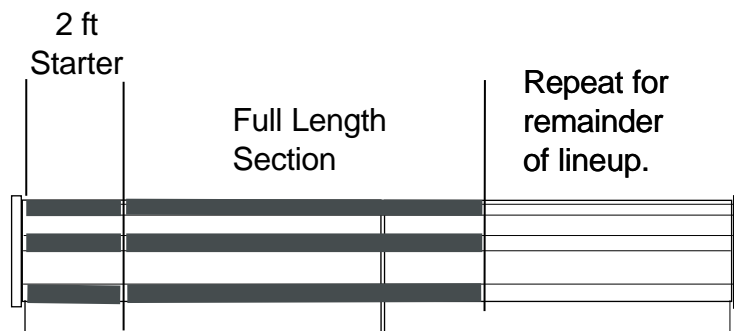
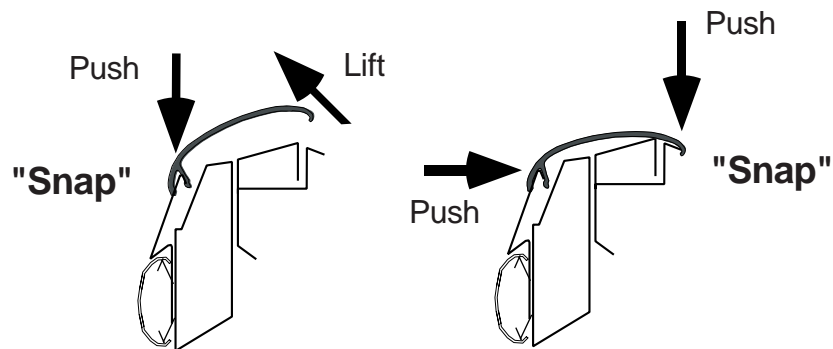
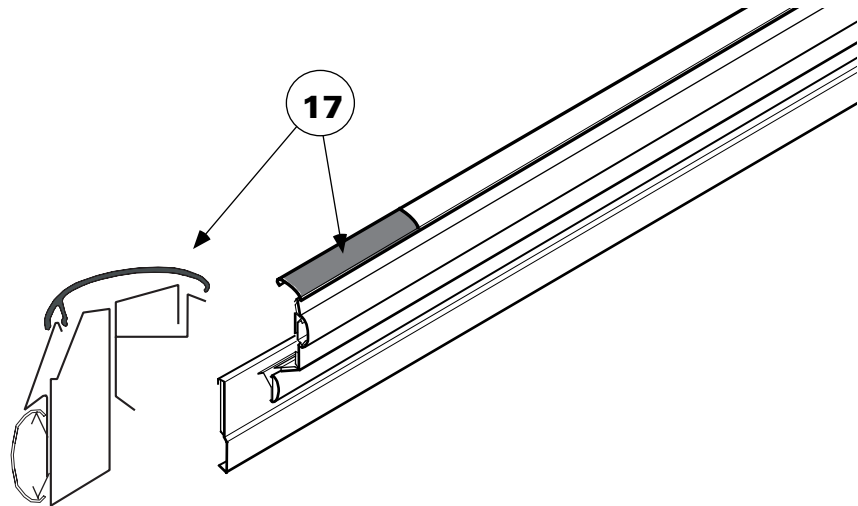

*Single Deck & Multideck  
Meat, Produce, & Dairy  
Contour End Kit*

P/N 376454C

Once all except the last sections of upper bumper and top rail have been installed refrigerate the case line up for at least six (6) hours.

**The last sections of upper bumper and top rail should be kept inside a refrigerated case or cooler during this time.** This will allow the bumpers and top rails to contract.

Go to the right end of the line up and tap the top rail and bumpers to close any gaps.

Measure between *right* end and installed rail or bumper. Cut the last sections of top rail and bumpers. Use a miter box and fine-toothed saw to cut last bumpers and top rail to length. Install internal trim flush to right end, then install cut top bumper. Install the last section of lower bumper and top rail.

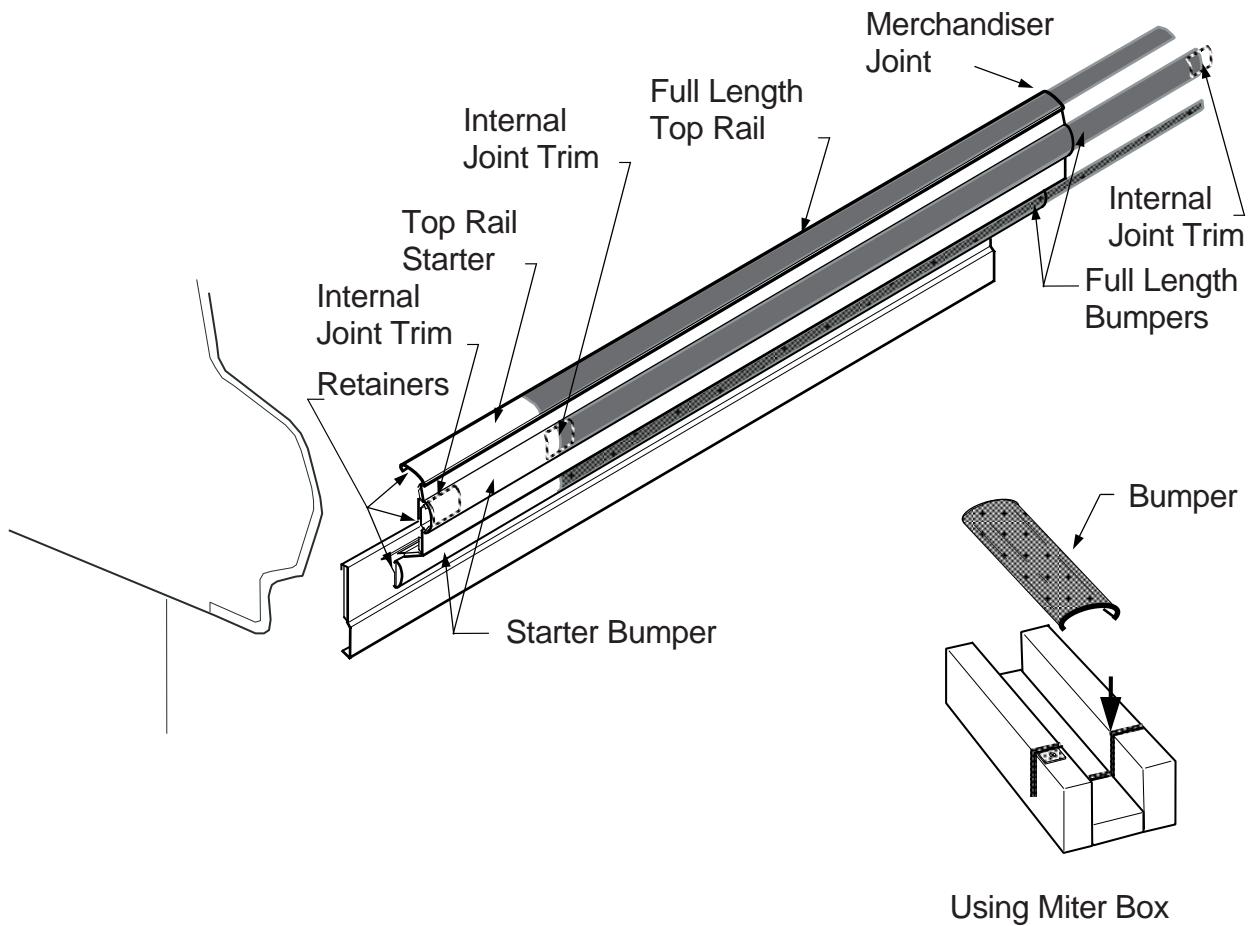

Optional End Bumper

- 1** Position **Bumper Retainer – 18** 5 3/8 inch forward of back edge of end assembly and level.

**ALL MEAT AND PRODUCE, D5L AND D6L:** Centerline groove of Retainer must be 9 3/4 inches above bottom edge of End Assembly.

**D5 AND D6:** Centerline groove of Retainer must be 13 1/16 inches above bottom edge of End Assembly.

**D5H:** Centerline groove of Retainer must be 17 1/16 inches above bottom edge of End Assembly.

Fasten with self-drilling **Screws – 19.**

- 2** Place **Bumper End Cap – 20** over each end of Retainer. Fasten with self-drilling **Screw – 19.**

- 3** Hook **End Bumper – 21** under retainer and snap into place at top.

Use a miter box and fine-toothed saw to trim bumper if installation is too tight.

