

Item	Part #	Description	Wiring Item #	Item	Part #	Description	Wiring Item #
FAN ASSEMBLIES AND THERMOSTATS				LAMPS AND BALLASTS			
A.	<u>9W Fan Assembly</u>		(1)	D.	0376409	Ballast, Electronic 2 lamps	(4)
	0047000	Fan Motor, Evaporator		D.	0376410	Ballast, Electronic 3 lamps	(4)
	0315470	Fan Blade embossing toward motor		E.		Fluorescent Lamp <i>Replace with like fixtures</i>	(5)
B.	<u>0411744</u>	Standard Non-adjustable Defrost Thermostat	(2)				
C.	0137880	Optional Adjustable Refrigeration Thermostat	(3)				

Note: Changed items have been underlined.

Engineering Plan Views



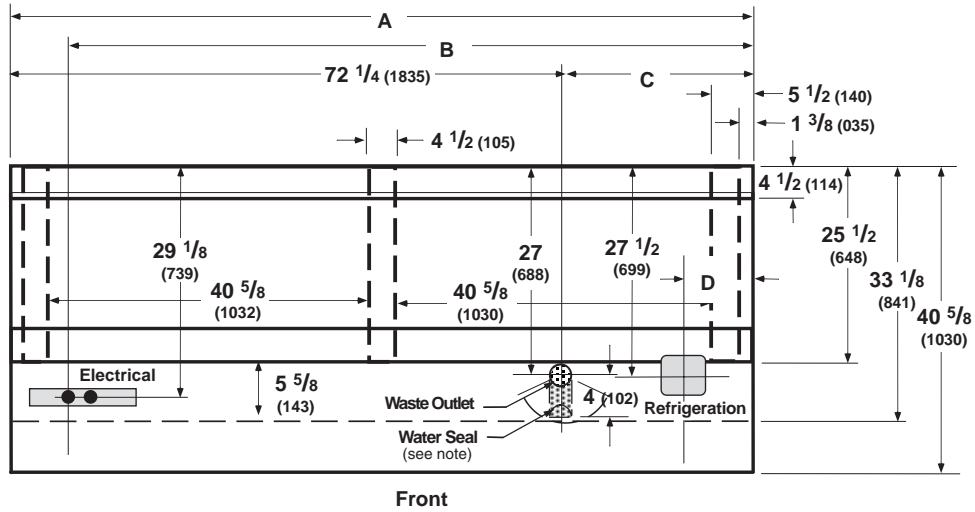

Dimensions shown as in. and (mm).

Narrow Dairy & Delicatessen

04-2003



Front

	8 ft	12 ft
General		
(A) Case Length (<i>without ends or partitions</i>)	96 ³ / ₈ (2448)	144 ¹ / ₂ (3670)
Maximum O/S dimension of case back to front (<i>includes bumper</i>)	40 ⁵ / ₈ (1030)	40 ⁵ / ₈ (1030)
Back of case to front of splashguard	33 (840)	33 (840)
Back of case to O/S edge of front skid rail	25 ¹ / ₂ (648)	25 ¹ / ₂ (648)
Width of skid rail	4 ¹ / ₂ (114)	4 ¹ / ₂ (114)
RH end of case to outside edge of external support	5 ¹ / ₂ (140)	5 ¹ / ₂ (140)
Distance between edges of external support and center support	40 ⁵ / ₈ (1032)	40 ⁵ / ₈ (1032)
Distance between edges of center supports	NA	44 (1118)
Stub-up area between front skid rail and splashguard	5 ⁵ / ₈ (143)	5 ⁵ / ₈ (143)
Electrical Service  (<i>Electrical Field Wiring connection point</i>)		
(B) RH End of case to center of farthest knockout	88 ³ / ₈ (2245)	136 ¹ / ₂ (3467)
Back of case to center of knockout	29 ¹ / ₈ (739)	29 ¹ / ₈ (739)
Length of electrical raceway	34 ⁵ / ₈ (878)	34 ⁵ / ₈ (878)
Waste Outlet 		
(C) RH End of case to the center of waste outlet	24 ¹ / ₈ (613)	72 ¹ / ₄ (1835)
LH End of case to the center of waste outlet	72 ¹ / ₄ (1835)	72 ¹ / ₄ (1835)
Back O/S of case to center of waste outlet	27 (686)	27 (686)
Water Seal 		
Edge of water seal to center of waste outlet	4 (102)	4 (102)
Outside diameter of the drip pipe	1 ¹ / ₂ (38)	1 ¹ / ₂ (38)
<i>NOTE: Water seal outlet must clear front skid rail; water seal rotation in forward direction only due to low base.</i>		
Refrigeration Outlet 		
Back of case to center of refrigeration outlet	27 ¹ / ₂ (699)	27 ¹ / ₂ (699)
(D) RH end of case to center of refrigeration outlet	9 (230)	9 (230)

Dimensions shown as in. and (mm).

Impact D6L
Dairy & Delicatessen

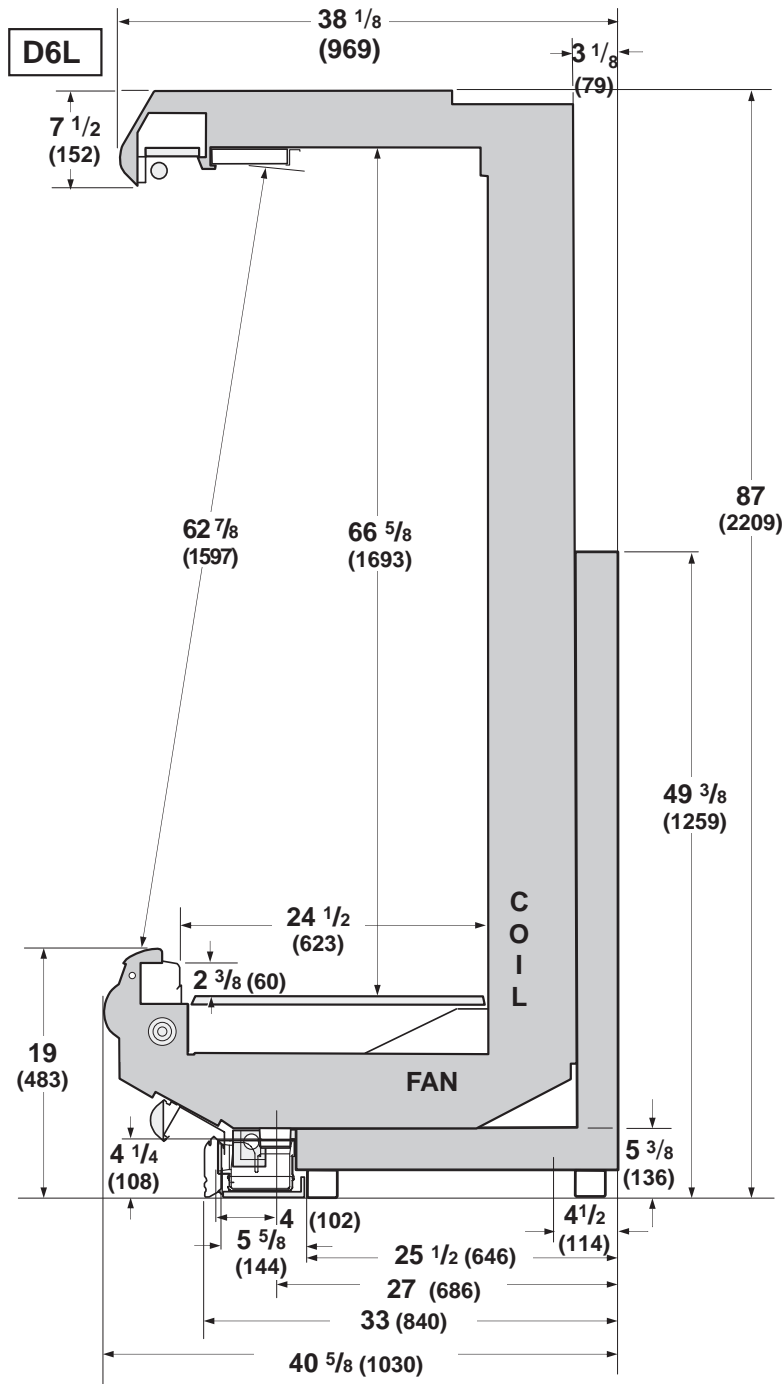

NOTE: The bumpers are 4 in. (102 mm) wide. The center of the top bumper is 18 1/8 in. (460 mm) from the floor, and the center of the lower bumper is 6 1/8 in. (155 mm) from the floor.

NSF Certification

These merchandisers are manufactured to meet ANSI / National Sanitation Foundation (NSF®) Standard #7 requirements.

REFRIGERATION DATA

Note: This data is based on store temperature and humidity that does not exceed 75°F and 55% R.H.

	D6L	D6LE
Discharge Air °F	31	32
Evaporator °F	21	24
Unit Sizing °F	19	22
Btu/hr/ft*	D6L	D6LE
LIT & UNLIT SHELVES		
Parallel	1550	1490
Conventional	1660	1595
HUSSMANN PEG SHELVES (DELI ONLY)		
Parallel	1755	1685
Conventional	1855	1785

*For all refrigeration equipment other than Hussmann, use conventional Btu values.

DEFROST DATA

Frequency Hrs	6	6
Defrost Water (lb/ft/day)	10.50	
(± 15% based on case configuration and product loading).		
OFFTIME	D6L	D6LE
Temp Term °F	48	48
Failsafe Minutes	30	35

ELECTRIC OR GAS Not Recommended

Standard Defrost Thermostat

Close on rise: close 48°F — open 33°F

CONVENTIONAL CONTROLS

Low Pressure Backup Control

CI/CO**	D6L	D6LE
	14°F / 4°F	17°F / 7°F

Indoor Unit Only, Pressure Defrost

Termination** 48°F

**Use a Temperature Pressure Chart to determine PSIG conversions.

PHYSICAL DATA

Merchandiser Drip Pipe (in.)	1 1/2
Merchandiser Liquid Line (in.)	3/8
Merchandiser Suction Line (in.)	7/8

Estimated Charge (lb)***

	D6L	D6LE
8 ft	2.3	2.7
12 ft	3.3	3.9

***This is an average for all refrigerant types. Actual refrigerant charge may vary by approximately half a pound.

Length Added to Lineup by

Each End (in.)	1 1/2
Each Insulated Partition (in.)	1 1/2

Impact D6L Dairy & Delicatessen
--

Electrical Data

Number of Fans	8 ft	12 ft		
Refrigeration – 9W	4	6		
Export – 9W	4	6		
	Amperes		Watts	
Merchandiser	8 ft	12 ft	8 ft	12 ft
Fans (Refrigeration)				
Standard (120V 60Hz)	2.80	4.20	<u>210</u>	<u>320</u>
Energy Efficient (120V 60Hz)	<u>1.52</u>	<u>2.28</u>	<u>100</u>	<u>150</u>
Export (230V 50Hz)	<u>1.52</u>	<u>2.28</u>	<u>228</u>	<u>342</u>
Constant On Anti-sweat Heaters	NA	NA	NA	NA
Cycling Anti-sweat Heaters	NA	NA	NA	NA
Minimum Circuit Ampacity				
With Standard Fans (120V 60Hz)	3.00	4.40		
With Energy Efficient Fans (120V 60Hz)	<u>1.72</u>	<u>2.48</u>		
With Export Fans (230V 50Hz)	<u>1.72</u>	<u>2.48</u>		
Maximum Over Current Protection 120V	20	20		
Export (230V 50Hz)	<u>15</u>	<u>15</u>		
Electric Defrost Heaters (208V 1Φ)	NA	NA	NA	NA
Gas Defrost Heaters (208V)	NA	NA	NA	NA
Standard Lighting	8 ft	12 ft	8 ft	12 ft
1 Row Canopy	0.51	0.77	59	85
Optional Lighting				
1 Row Canopy and 1 Row Rail	1.02	1.54	118	170
2 Rows Canopy	1.02	1.54	118	170
2 Rows Canopy and 1 Row Rail	1.53	2.31	177	255
Optional Shelf Lighting				
1 Row Shelves	0.51	0.77	59	85
2 Rows of Shelves	1.02	1.54	118	170
3 Rows of Shelves	1.53	2.31	177	255
4 Rows of Shelves	2.04	3.08	236	340
5 Rows of Shelves	2.55	3.85	295	425

Fan Wiring Offtime Defrost

4 & 6 Fans

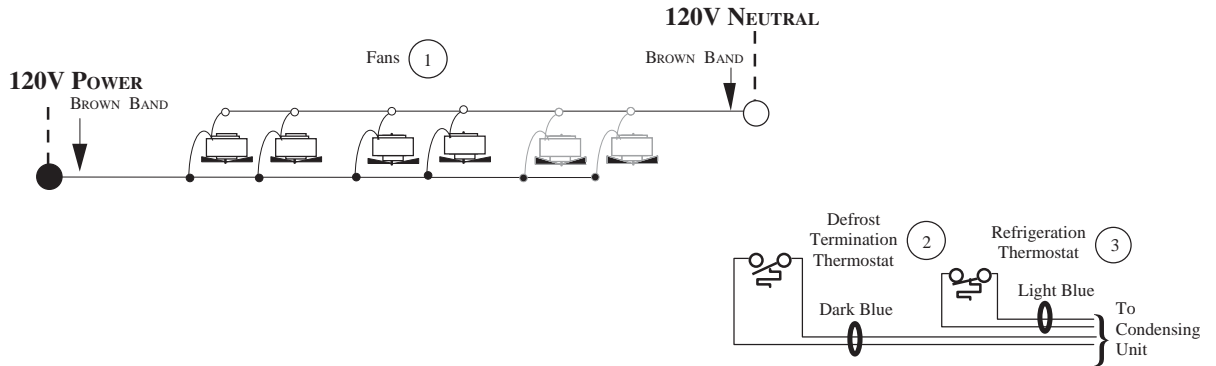

Optional Shelf Harness and Light Circuits for One Row of Shelves

Shelf Lighting

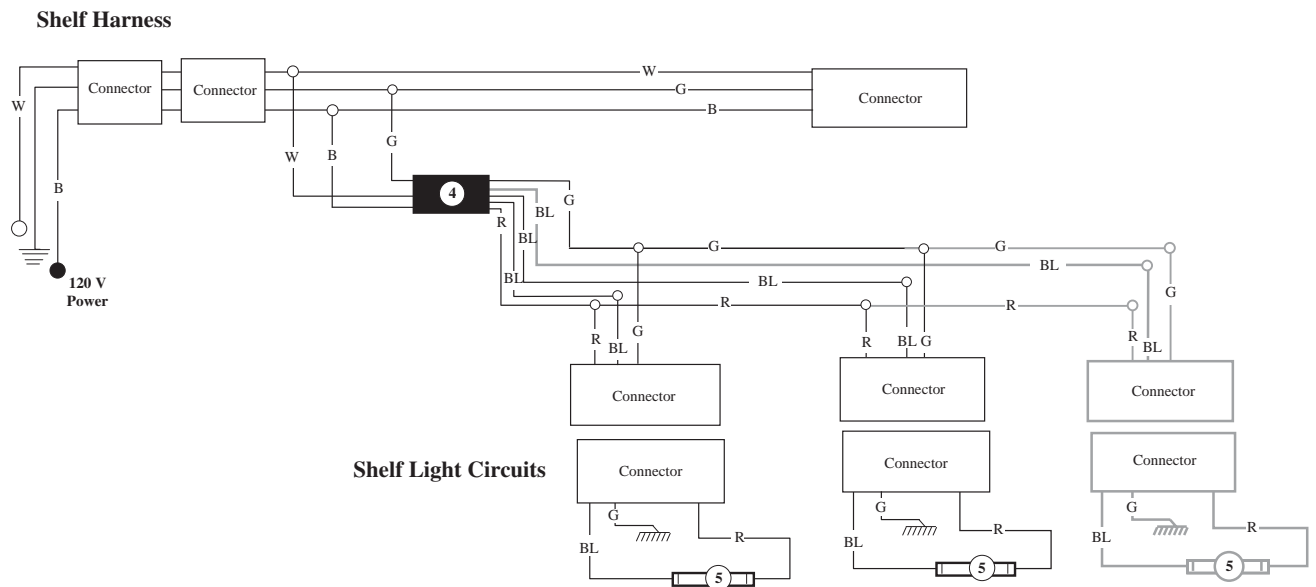

WARNING

All components must have mechanical ground, and the merchandiser must be grounded.

CIRCLED NUMBERS = PARTS LIST ITEM NUMBERS

Grayed components in 12 foot models only.

R = Red Y = Yellow G = Green BL = Blue B = Black W = White

● = 120V POWER ○ = 120V NEUTRAL ≡ = FIELD GROUND ≡ = CASE GROUND

Light Circuits

Standard Lighting 1 Row Canopy or Optional 1 Row Rail

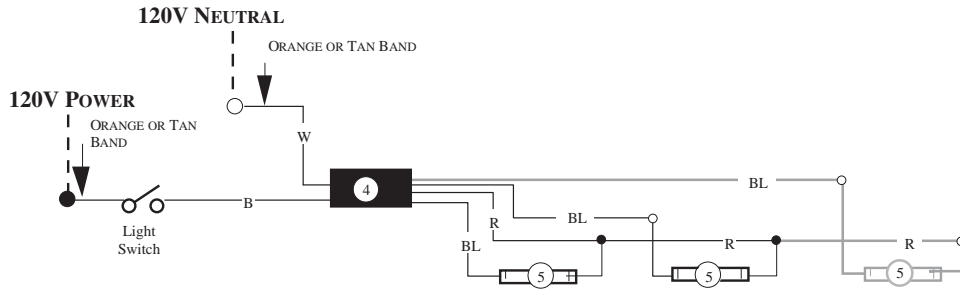

Optional Lighting 2 Rows Canopy

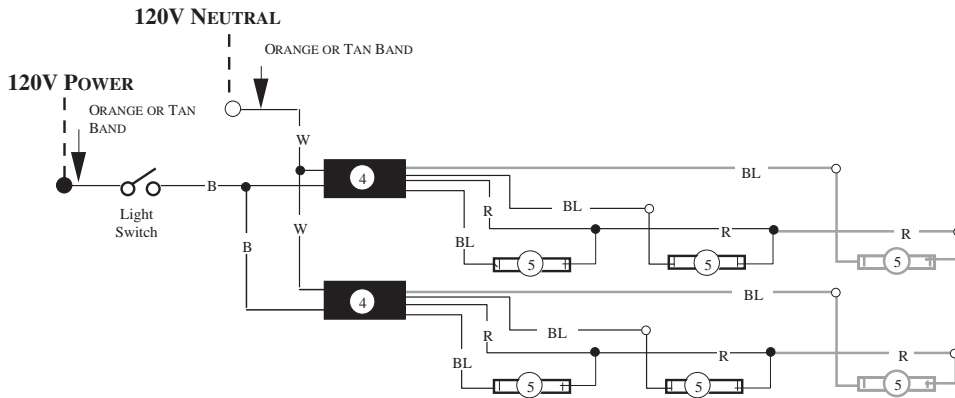

Optional Lighting 3 Row Canopy

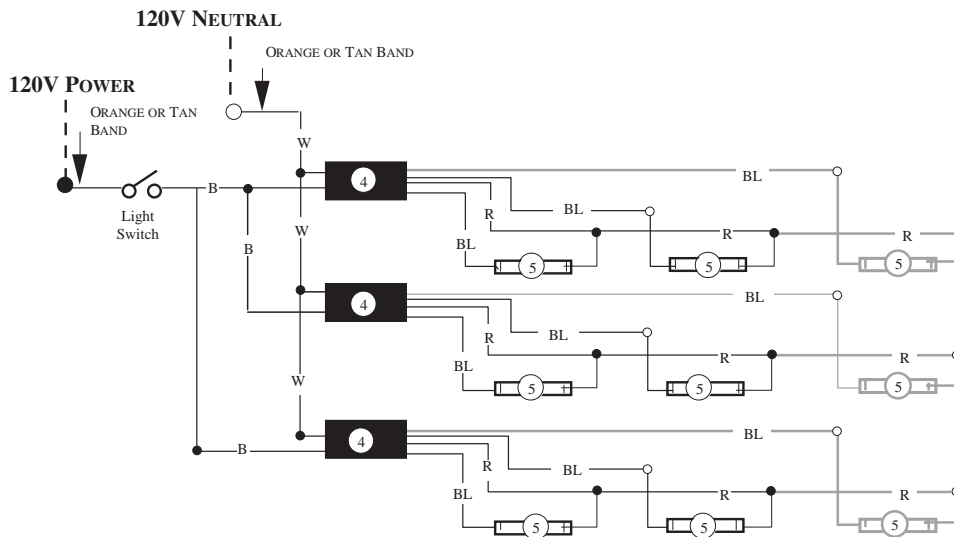

WARNING

All components must have mechanical ground, and the merchandiser must be grounded.

CIRCLED NUMBERS = PARTS LIST ITEM NUMBERS

Grayed components in 12 foot models only.

R = Red Y = Yellow G = Green BL = Blue B = Black W = White

● = 120V POWER ○ = 120V NEUTRAL