

We reserve the right to change or revise specifications and product design in connection with any feature of our products. Such changes do not entitle the buyer to corresponding changes, improvements, additions or replacements for equipment previously sold or shipped.

Item	Part #	Description	Wiring Item #	Item	Part #	Description	Wiring Item #
FAN ASSEMBLIES AND THERMOSTATS				LAMPS AND BALLASTS			
A.	6W Fan Assembly		(1)	D.	0428648	Ballast, Electronic 2 lamps	(4)
	0058698	Fan Motor, Evaporator		D.	0428649	Ballast, Electronic 3 lamps	(4)
	0142780	Fan Blade embossing toward motor		E.		Fluorescent Lamp <i>Replace with like fixtures</i>	(5)
B.	0411744	Standard Non-adjustable Defrost Thermostat	(2)				
C.	0137880	Optional Adjustable Refrigeration Thermostat	(3)				

The M2G has been discontinued.

Note: Changed items have been underlined.

Engineering Plan Views

Dimensions shown as inches and (mm).

Meat, Delicatessen and Precut Produce

M2GE

08-2003

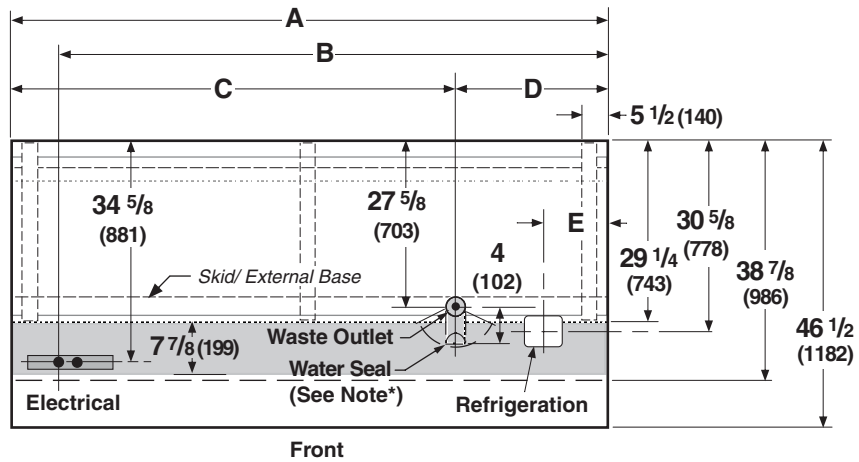

General	8 ft	12 ft
(A) Case Length (<i>without ends or partitions</i>)	96 3/8 (2448)	144 1/2 (3670)
Maximum outside dimension of case back to front (<i>includes bumper</i>)	46 1/2 (1182)	46 1/2 (1182)
Back of case to front of splash guard	38 7/8 (986)	38 7/8 (986)
Back of case to outside edge of front skid rail	29 1/4 (743)	29 1/4 (743)
Width of skid rail	4 1/2 (114)	4 1/2 (114)
Right-hand end of case to inside edge of external support	5 1/2 (140)	5 1/2 (140)
Distance between edges of external support and center support	40 5/8 (1032)	40 5/8 (1032)
Distance between edges of center supports	NA	44 (1118)
Stub-up area between front skid rail and splash guard	7 7/8 (199)	7 7/8 (199)
Electrical Service (<i>Electrical Field Wiring connection point</i>)		
(B) Right-hand end of case to center of farthest knockout	88 3/8 (2245)	136 1/2 (3467)
Back outside of case to center of knockout	34 5/8 (881)	34 5/8 (881)
Length of electrical raceway	34 1/2 (878)	34 1/2 (878)
Waste Outlet		
(C) Left-hand end of case to the center of waste outlet	72 1/4 (1835)	72 1/4 (1835)
(D) Right-hand end of case to the center of waste outlet	24 1/8 (613)	72 1/4 (1835)
Back outside of case to center of waste outlet	27 5/8 (702)	27 5/8 (702)
Water Seal		
Edge of water seal to center of waste outlet	4 (102)	4 (102)
Outside diameter of the drip pipe	1 1/2 (38)	1 1/2 (38)
*Note: Water seal outlet must clear front skid rail. M2E & M2GE water seal rotation in forward direction only, due to low base.		
Refrigeration Outlet		
(E) Right-hand end of case to center of refrigeration outlet	9 (230)	9 (230)
Back of case to center of refrigeration outlet	30 5/8 (778)	30 5/8 (778)

Multi-deck, 3 or 4 Display Levels, with Front Glass

The M2G has been discontinued.

**Impact M2GE
Meat, Delicatessen,
and Pre-cut Produce**

Dimensions shown as inches and (mm).

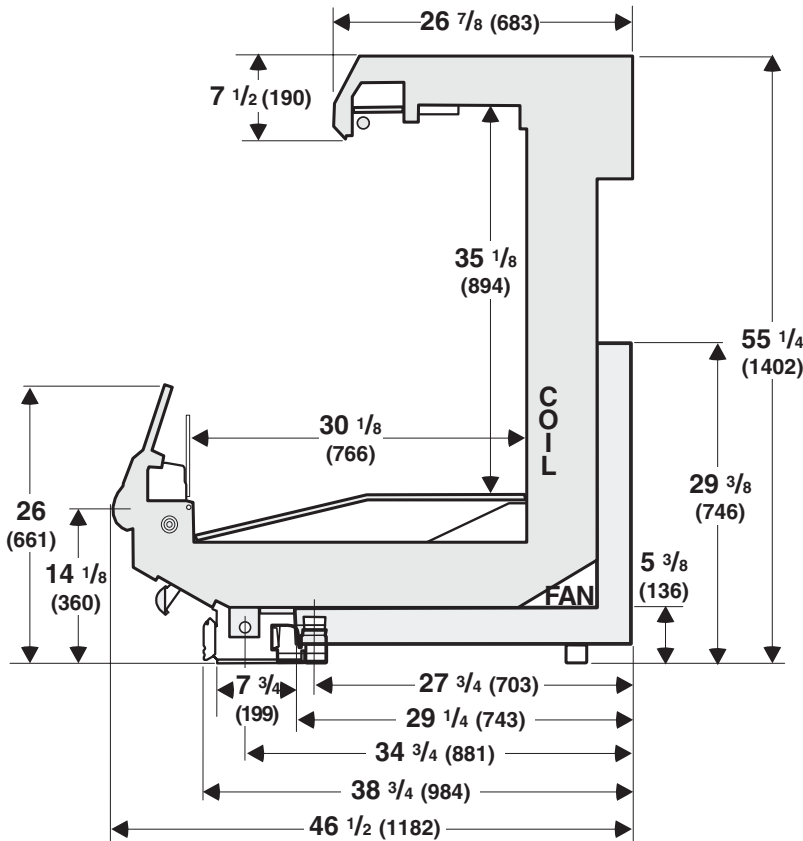

REFRIGERATION DATA

Note: This data is based on store temperature and humidity that does not exceed 75°F and 55% R.H.

	M2GE
Discharge Air (°F)	29
Evaporator (°F)	21
Unit Sizing (°F)	19

Btu/hr/ft*	M2GE
Parallel	915
Conventional	985

*For all refrigeration equipment other than Hussmann, use conventional Btu values.

DEFROST DATA

	M2GE
Frequency (hr)	6
Defrost Water (lb/ft/day)	6
($\pm 15\%$ based on case configuration and product loading).	

OFFTIME	M2GE
Temp Term (°F)	48°F
Failsafe (minutes)	30

ELECTRIC OR GAS Not Recommended

Standard Defrost Thermostat

Close on rise: close 48°F — open 33°F

CONVENTIONAL CONTROLS

Low Pressure Backup Control

	M2GE
CI/CO**	14°F / 4°F

Indoor Unit Only, Pressure Defrost

Termination** 48°F

**Use a Temperature Pressure Chart to determine PSIG conversions.

PHYSICAL DATA

Merchandiser Drip Pipe (in.)	1 1/2
Merchandiser Liquid Line (in.)	3/8
Merchandiser Suction Line (in.)	7/8

Estimated Charge (lb)***

8 ft	2.3
12 ft	3.3

***This is an average for all refrigerant types.

Actual refrigerant charge may vary by approximately half a pound.

Length (in.) added to Lineup by Each End or Insulated Partition 1 1/2

NSF Certification

These merchandisers are manufactured to meet ANSI /National Sanitation Foundation (NSF®) Standard #7 requirements.

Impact M2GE Meat, Delicatessen and Pre-cut Produce

Electrical Data

	8 ft	12 ft		
Number of Fans – 6W	2	3		
	Amperes		Watts	
Merchandiser	8 ft	12 ft	8 ft	12 ft
Fans (Refrigeration)				
Standard (120V 60Hz)	<u>1.00</u>	<u>1.50</u>	<u>78</u>	<u>117</u>
Energy Efficient (120V 60Hz)	<u>0.52</u>	<u>0.78</u>	<u>36</u>	<u>54</u>
Export (230V 50Hz)	<u>0.56</u>	<u>0.84</u>	<u>88</u>	<u>132</u>
Cycling Anti-sweat Heaters	NA	NA	NA	NA
Minimum Circuit Ampacity				
With Standard Fans (120V 60Hz)	<u>1.20</u>	<u>1.70</u>		
With Energy Efficient Fans (120V 60Hz)	<u>0.72</u>	<u>0.98</u>		
With Export Fans (230V 50Hz)	<u>0.76</u>	<u>1.04</u>		
Maximum Over Current Protection 120V	20	20		
Maximum Over Current Protection 230V	15	15		
Standard Lighting	8 ft	12 ft	8 ft	12 ft
1 Row Canopy	0.51	0.77	59	85
Optional Lighting				
1 Row Canopy and 1 Row Rail	1.02	1.54	118	170
2 Row Canopy	1.02	1.54	118	170
2 Row Canopy and 1 Row Rail	1.53	2.31	177	255
3 Row Canopy	1.53	2.31	177	255
3 Row Canopy and 1 Row Rail	2.04	3.08	2.36	3.40
Optional Shelf Lighting				
1 Row of Shelves	0.51	0.77	59	85
2 Rows of Shelves	1.02	1.54	118	170
3 Rows of Shelves	1.53	2.31	177	255

Fan Wiring Offtime Defrost

2 & 3 Fans

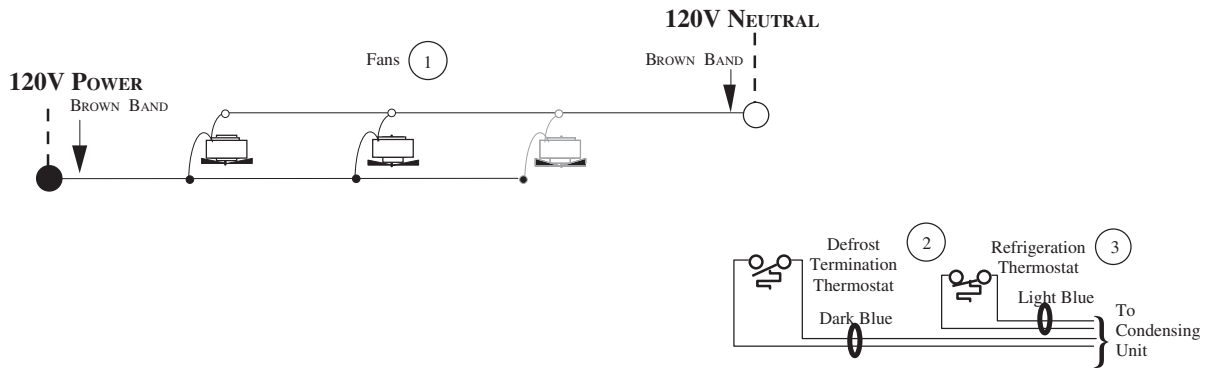

Optional Shelf Harness and Light Circuits for One Row of Shelves

Shelf Lighting

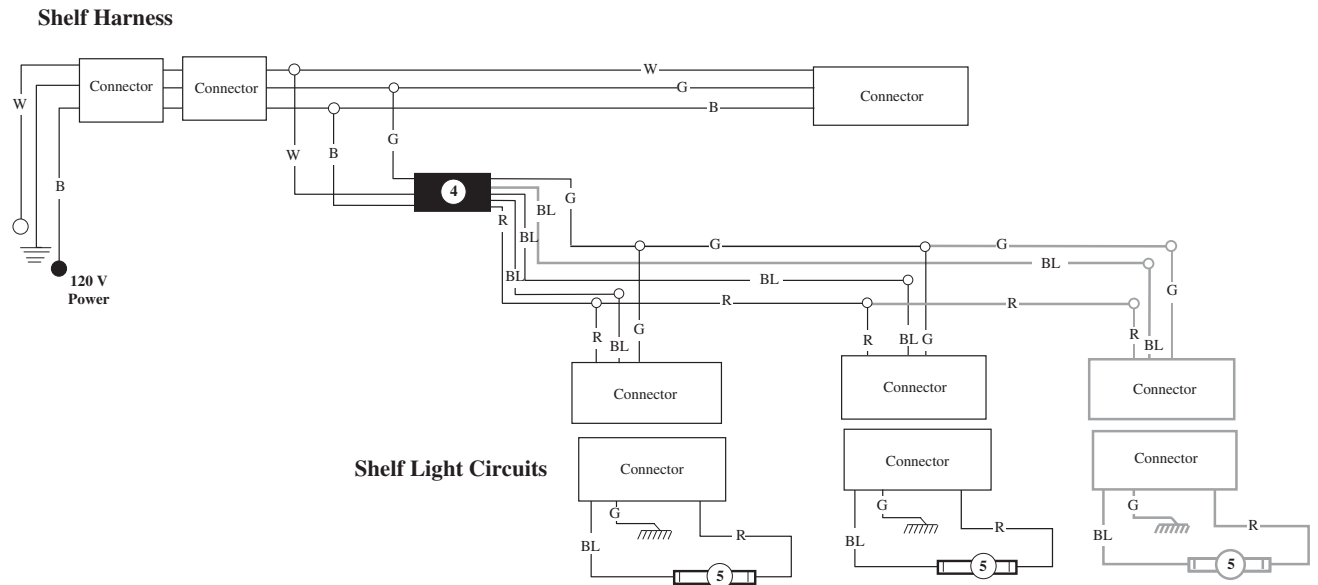

WARNING

All components must have mechanical ground, and the merchandiser must be grounded.

CIRCLED NUMBERS = PARTS LIST ITEM NUMBERS

Grayed components in 12 foot models only.

R = Red Y = Yellow G = Green BL = Blue B = Black W = White

● = 120V POWER ○ = 120V NEUTRAL ≡ = Field Ground ≡ = Case Ground

Light Circuits

Standard Lighting 1 Row Canopy or Optional 1 Row Rail

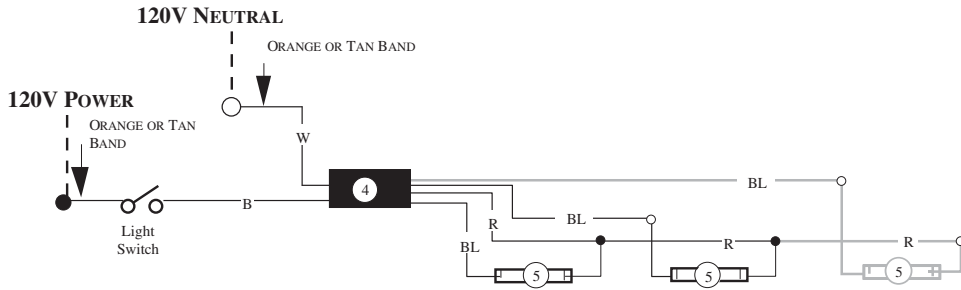

Optional Lighting 2 Row Canopy

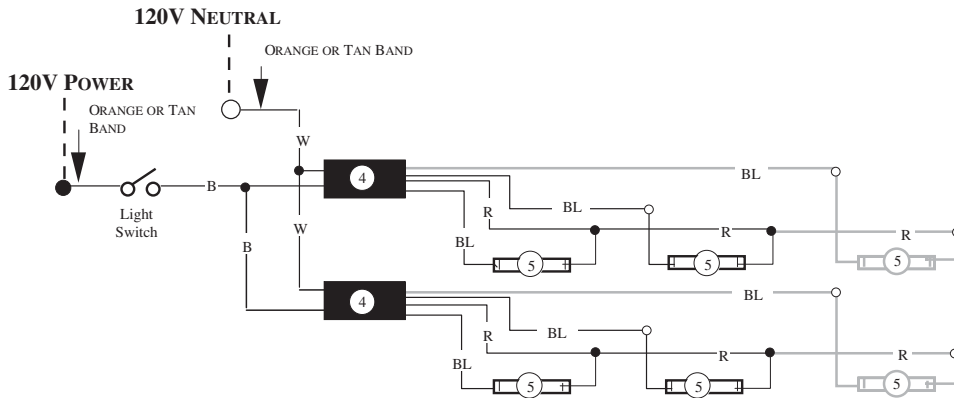

Optional Lighting 3 Row Canopy

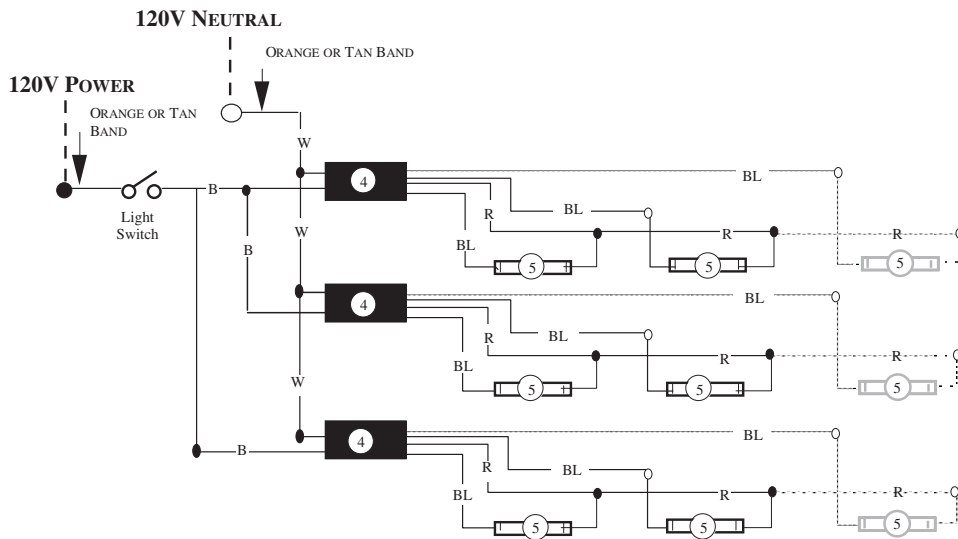

WARNING

All components must have mechanical ground, and the merchandiser must be grounded.

CIRCLED NUMBERS = PARTS LIST ITEM NUMBERS

Grayed components in 12 foot models only.

R = Red Y = Yellow G = Green BL = Blue B = Black W = White

● = 120V POWER ○ = 120V NEUTRAL

The shelf configuration of these merchandisers is critical!

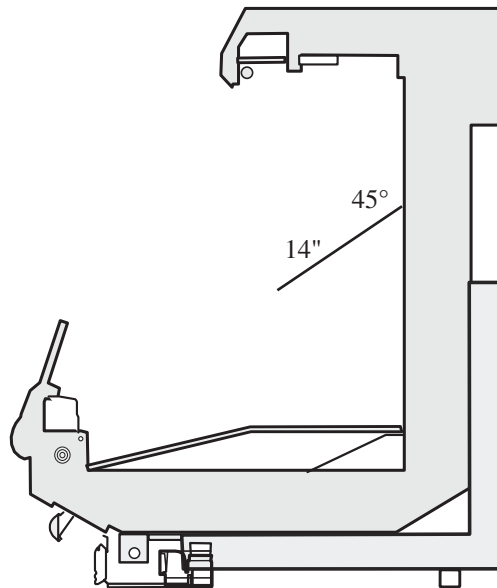

Shelf Configuration for M2GE

Top shelf must be 14 inches wide and placed at a 45° angle.

These shelf positions apply to all product applications.