

HUSSMANN®



Reach-in Merchandisers

Medium and Low Temperature



Installation & Operation Manual

Shipped With Case Data Sheets

P/N 0387183_Q

May 2015

IMPORTANT

**Keep in store for
future reference!**

MANUAL- I/O REACH-IN

English P/N 0387183

Spanish P/N 0517045

French P/N 0527085

Table of Contents

INSTALLATION

NSF Certification 1-1
Location 1-1
Shipping Damage 1-1
Exterior Loading 1-2
Merchandisers Shipped With End Installed..... 1-2
Shipping Braces 1-2
Moving Through Narrow Entrances..... 1-3
Leveling 1-6
Joining 1-8
Splashguards 1-23
Installing Bumpers..... 1-24

REFRIGERATION / ELECTRICAL

Refrigerant 2-1
Refrigerant Piping..... 2-1
Insulation 2-2
Branch Line Piping 2-3
Expansion Valve Adjustment 2-4
Refrigeration Thermostat 2-4
Defrost Termination Thermostat 2-5
Control Settings 2-7
Merchandiser Electrical Data 2-9
Field Wiring 2-9
Electrical Connections 2-9
Identification of Wiring 2-9
Wiring Color Code 2-10

DRIP PIPING AND SPLASHGUARDS

Waste Outlet and Water Seal 3-1
Installing Drip Piping 3-1
Drip Piping Lineup Arrangements 3-4
Installing Splashguards 3-5
Sealing Splashguard to Floor 3-5

START UP / OPERATION

Start up 4-1
Stocking 4-1
Load Limits 4-1
Load Limit Profiles..... 4-1
Installing FDA/NSF Required Thermometer 4-2

MAINTENANCE

Care and Cleaning..... 5-1
Cleaning Honeycomb Assemblies..... 5-2
Cleaning Under Merchandisers 5-2
Removing Scratches from Bumper 5-2

SERVICE

Replacing Fan Motors and Blades 6-1
Replacing Electric Defrost Heaters 6-3
Replacing Drain Pan Heater 6-5
RLT with Gas Defrost Only: Replacing
Slave Plate Heater 6-6
Servicing Vertical Lighting 6-7
Servicing Doors and Frames 6-7
Replacing Door or Door Frame Parts 6-7
Replacing Damaged Drain Fitting 6-7
Repairing Aluminum Coils 6-8

WARRANTY

IMPORTANT
KEEP IN STORE FOR FUTURE REFERENCE

Quality that sets industry standards!

This merchandiser is NSF® certified.

12999 St. Charles Rock Road • Bridgeton, MO 63044-2483

U.S. & Canada 1-800-922-1919 • Mexico 1-800-890-2900

www.hussmann.com

© 2015 Hussmann Corporation

INSTALLATION TOOL LIST

Unloading From Trailer:

Lever Bar (also know as a Mule,
Johnson Bar, J-bar, Lever Dolly,
and pry lever)
Moving Dolly

Setting Case Line-Up:

Level, 4 ft suggested
Ratchet
1/4 in. Socket
5/16 in. Socket
1/2 in. Socket
Battery Drill/Screw Gun
Caulking Gun
10 in. Adjustable Crescent Wrench

ANSI Z535.5 DEFINITIONS



• **DANGER** – Indicate[s] a hazardous situation which, if not avoided, will result in death or serious injury.



• **WARNING** – Indicate[s] a hazardous situation which, if not avoided, could result in death or serious injury.



• **CAUTION** – Indicate[s] a hazardous situation which, if not avoided, could result in minor or moderate injury.

• **NOTICE** – Not related to personal injury – Indicates[s] situations, which if not avoided, could result in damage to equipment.

REVISION HISTORY

REVISION Q — MAY 2015

1. Redesigned manual to 1/2 letter size

REVISION P — OCTOBER 2014

1. California Warning Statement, Page 1-2; changed to 2 in. partition kit, Page 1-7; Shim location, Page 1-6; End Caps, Page 1-8; Removed screws, Page 2-2; Time Termination, Page 2-8, 2-9; No thread sealer, Page 3-2, 3-3; RLT load limit drawing, Page 4-2; Ammonia cleaners, Page 5-3; Number 11, Page 6-1, 6-2; Heater drawings, Page 6-4, 6-5; Removed number 2 teflon tape, Page 6-7.

REVISION N — APRIL 2013

1. Inserted Joining Instructions, Pages 1-8 - 1-22

REVISION M — MARCH 2013

1. Revised caution note on page 1-1; added to Page 4-1.

REVISION L — AUGUST 2012

1. Updated instructions for moving case through small doors, Section 1.

REVISION K — JULY 2012

1. Included instructions for clearing smaller store entrances, Section 1. Ice cream note added to Page 4-1.

REVISION J — APRIL 2012

1. Corrected Table of Contents, page iii.

REVISION I — NOT ISSUED

REVISION H — MARCH 2012

1. Amended Installing Drip Piping procedure, Page 3-2.

REVISION G — MARCH 2010

1. Revised Installing Drip Piping procedure, Pages 3-1 through 3-6.

REVISION F — DECEMBER 2009

1. Changed shimming drawing, Page 1-3.
2. Updated drip piping pitch, Page 3-1.
3. Added page division lines for thermometer, Page 4-3.
4. Added cleaning stainless steel rails, Page 5-2.
5. Added heater front and rear drawing, Page 6-3.
6. Updated warnings and cautions throughout
7. Added new back cover

REVISION E — JANUARY 2009

1. Added page division lines for thermometer, Page 4-3.
2. Added heater front and rear drawing, Page 6-3.
3. Changed shimming drawing, Page 1-3.

REVISION D — SEPTEMBER 2007

1. Added front panel text and illustration, Page 1-2.
2. Clarified shimming directions, Page 1-3.
3. Added RLT information throughout.
4. Added note to remove bumper protective film, Page 1-6.
5. Added information on Always*Clear™ glass, page 5-1.
6. Removed reference to Anthony doors, Page 6-5.
7. Added repairing aluminum coil, Page 6-12.
8. Changed warranty page.
9. Added Installation Tool List, Page iv.
10. Added revision history, Page iv.

REVISION C — JUNE 2002

1. Added NSF information, Pages 1-1,4-2 through 4-4.
2. Sections 2 through 6 are completely rewritten.
3. Changed warranty to March 15,2002.

INSTALLATION

NSF CERTIFICATION

These merchandisers are manufactured to meet ANSI / National Sanitation Foundation (NSF[®]) Standard #7 requirements. Proper installation is required to maintain certification. Near the serial plate, each case carries a label identifying the type of application for which the case was certified.

ANSI/NSF-7 Type I – Display Refrigerator / Freezer
Intended for 75°F / 55%RH Ambient Application

ANSI/NSF-7 Type II – Display Refrigerator / Freezer
Intended for 80°F / 55%RH Ambient Application

ANSI/NSF-7 – Display Refrigerator
Intended for Bulk Produce

LOCATION

These merchandisers are designed for displaying products in air conditioned stores where temperature is maintained at or below the ANSI/NSF-7 specified level and relative humidity is maintained at or below 55%.

Placing refrigerated merchandisers in direct sunlight, near hot tables or near other heat sources could impair their efficiency.

Like other merchandisers, these are sensitive to air disturbances. Air currents passing around merchandisers will seriously impair their operation. Do NOT allow air conditioning, electric fans, open doors or windows, etc. to create air currents around the merchandisers.

To prevent sweating on the exterior surfaces of merchandisers, there must be A MINIMUM CLEARANCE OF 4 INCHES (102 MM) between the merchandisers and other fixtures or walls.

Product should always be maintained at proper temperature. This means that from the time the product is received, through storage, preparation and display, the temperature of the product must be controlled to maximize the life of the product.

SHIPPING DAMAGE

All equipment should be thoroughly examined for shipping damage before and during unloading.

This equipment has been carefully inspected at our factory. Any claim for loss or damage must be made to the carrier. The carrier will provide any necessary inspection reports and/or claim forms.

Apparent Loss or Damage

If there is an obvious loss or damage, it must be noted on the freight bill or express receipt and signed by the carrier's agent; otherwise, carrier may refuse claim. The carrier will supply necessary forms.

Concealed Loss or Damage

When loss or damage is not apparent until after equipment is uncrated, a claim for concealed damage is made. Upon discovering damage, make request in writing to carrier for inspection within 15 days and retain all packing. The carrier will supply inspection report and required claim forms.



EXTERIOR LOADING

Do NOT walk on top of merchandisers or damage to the merchandisers and serious personal injury could occur. THEY ARE NOT STRUCTURALLY DESIGNED TO SUPPORT EXCESSIVE EXTERNAL LOADING such as the weight of a person. Do not store items or flammable materials atop the unit.

For California Businesses:



This warning is the result of the California State law known as the California Safe Drinking Water and Toxic Enforcement Act of 1986, which is commonly referred to as “Proposition 65.”

This warning does not mean that Hussmann products will cause cancer or reproductive harm, or is in violation of any product-safety standards or requirements. As clarified by the California State government, Proposition 65 can be considered more of a ‘right to know’ law than a pure product safety law. When used as designed, Hussmann believes that our products are not harmful. We provide the Proposition 65 warning to stay in compliance with California State law. It is your responsibility to provide accurate Proposition 65 warning labels to your customers when necessary. For more information on Proposition 65, please visit the California State government website.

MERCHANDISERS SHIPPED WITH END INSTALLED

If the case was shipped with the end installed, two long bolts were used to hold the shipping brace to the end. If the shipping bolts are reinserted after removing the brace, they will extend into the product area and may damage the coil. THEREFORE, BE SURE TO REPLACE THESE BOLTS WITH THE SHORTER BOLTS PROVIDED.

Be careful not to damage the factory-installed end while moving the merchandiser. Make sure that tools are positioned past the end and beneath the merchandiser’s support bar.

SHIPPING BRACES

Move the merchandiser as close as possible to its permanent location and then remove all packaging. Check for damage before discarding packaging. Remove all separately packed accessories such as kits and shelves.

Locate the shipping block in the center of the heat exchanger (see illustration), and remove it before piping the merchandiser. This block was installed to minimize shipping vibration.

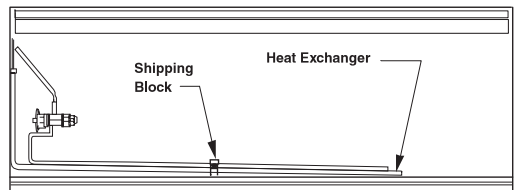

Top View of Merchandiser

MOVING MERCHANDISER THROUGH NARROW STORE ENTRANCES

Some exterior merchandiser parts may be disassembled for transit access through small doors or passage ways. This procedure takes approximately 30 minutes to assemble and reassemble one case. Contact your Hussmann representative to see if store merchandisers have this kit option. The case height without these components installed on top is 82.75 in. (2102 mm). Case depth is 35.5 in. with handles, wireway pan and external frames removed.

Follow the steps below to decrease the merchandiser profile for narrow access:

1. Remove the door handles.



2. Remove the front bumper. Pull from the bottom and set aside.



3. Remove the lower front panel to access the wireway.

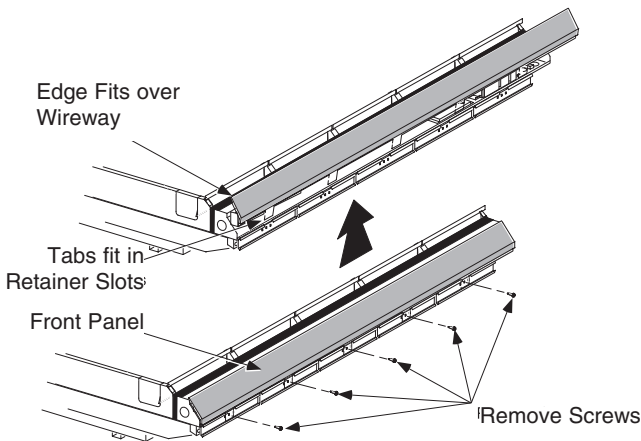

4. Remove the screws that attach the wireway pan to the bottom assembly.

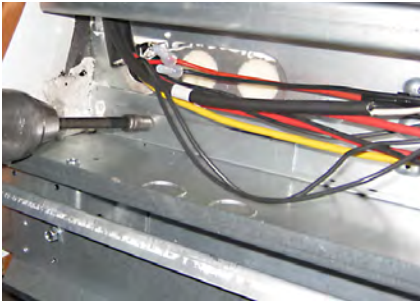

5. Detach the rubber and plastic gromets from the wireway pan.



6. Remove the screws that attach the grounding lug to the wireway pan.



7. Slide the wireway pan out, and remove it from the case. Bumper brackets and supports are attached to wireway pan. Removing the pan will remove the entire assembly.

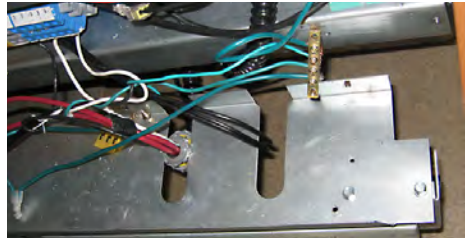

8. Remove the back, external braces from the rear of the case as shown below. Braces will slide straight back away from the case when nuts and screws are removed.



6 nuts and 1 bottom screw per external brace

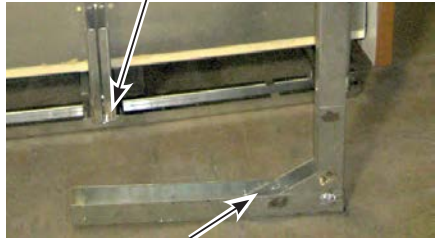

Bottom screw is located approximately 10 inches inboard from the rear of the case. Bottom screw location on removed rear brace.

Check the following before the rear of the case is positioned at its final location according to the store plan:

1. The external braces must be reinstalled with (6) nuts per brace, torqued to 24 foot pounds.



CAUTION

**Do not walk on top of merchandiser.
Do not store items or
flammable materials atop the unit.”**

FINAL LOCATION

Once the case reaches its final location, reassemble the wireway and door handles as follows:

1. Reinstall wireway pan in reverse order of removal.
2. **The ground lug must be reinstalled using the screws provided.**
3. **Replace the conduit connectors and plastic grommets to the wireway pan.**
4. Replace wireway cover, bumper and door handles.

LEVELING

Merchandisers must be installed level to ensure proper operation of the refrigeration system and to ensure proper drainage of defrost water. When leveling merchandisers, use a carpenter's level as shown.

Metal leveling shims or wedges are provided with each merchandiser for use if needed.



CAUTION

**Rear external frames must be
reinstalled securely before setting
or unloading shelves.
DO NOT WALK ON TOP OF THE MERCHANDISER.
DO NOT PLACE HEAVY OBJECTS ON CASE.**

LEVELING

Merchandisers must be installed level to ensure proper operation of the refrigeration system and to ensure proper drainage of defrost water. When leveling merchandisers, use a carpenter's level as shown.

Metal leveling shims or wedges are provided with each merchandiser for use if needed.

NOTE: BEGIN LINEUP LEVELING FROM THE HIGHEST POINT OF THE STORE FLOOR.

Place shims under the rail and make sure that they are positioned at a base component (crossbar). This transfers the weight directly from the loaded case through to the floor.

Placing shims at other locations will cause uneven distribution of weight leading to piping leaks, as well as sagging or wracked doors.

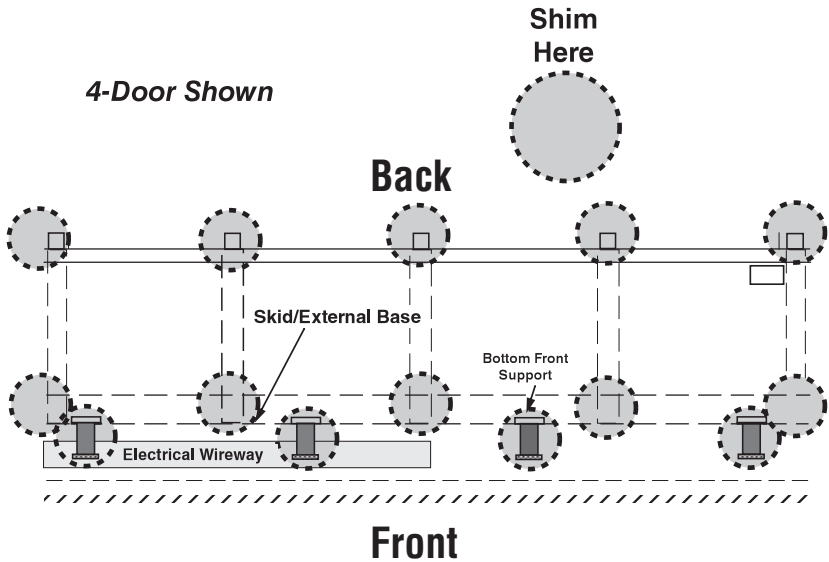
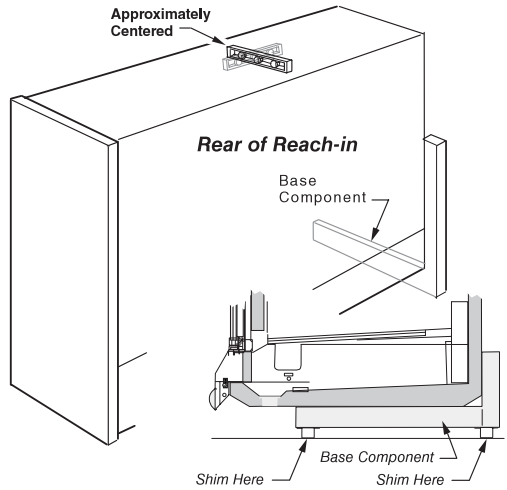

DOOR ADJUSTMENT

After leveling and joining the merchandisers, adjust and level doors according to manufacturer's instructions shipped with each product. Factory settings may be lost due to vibration during shipment.

JOINING

Sectional construction means that two or more merchandisers may be joined in line yielding one long continuous display requiring only one pair of ends. Joining kits and instructions are shipped with each merchandiser.

To join like fixtures, a joining kit is required. To join unlike fixtures, or like fixtures operating at different temperatures, a 2 inch (51 mm) partition kit is required. To join same temperature merchandisers on different defrost cycles, a plexiglass partition kit is required.

ALL JOINTS MUST BE AIR-TIGHT TO PREVENT FORMATION OF ICE OR CONDENSATION.

Refer to the instructions on the next page.

**RL / RM / RMF, RLT
RLN / RMN / RLNI / RLNIE
Joining Instructions**

Joining Instructions

Splashguard brackets must be installed before piping or wiring case.

PARTS LIST

Item

Quantity

Description

	RL/RM RM/RMF	RLN RMN	RLNI RLNIE	RLT	
1.	2	2	4	2	Donut Gasket
2.	1	1	2	2	Gasket, 1 x 1/2 x 180 in.
3.	1	1	2	1	Gasket, 1/2 x 1/4 x 180 in.
4.	8	8	14	6	Cap Screw 5/16 -18 x 1 1/4
5.	8	8	14	6	Split Lock Washers 5/16
6.	1	1	2	1	Joint Molding
7.	5	5	10	5	Binder Post and Screw
8.	1	1	2	1	Splice Connector

NOTE: Be sure first merchandiser has been leveled according to the main installation instruction. Carefully unpack and inspect the joining parts listed above to verify completeness and that there is no damage.

1 Prepare cases for joining (both sides of islands) as shown in Figure 1.

- A. Remove bumpers, rails, packing materials, and splashguards from the both cases.
- B. Remove shelves (if installed).
- C. Remove display racks and pans from ends to be joined.
- D. Remove rear shelf supports.

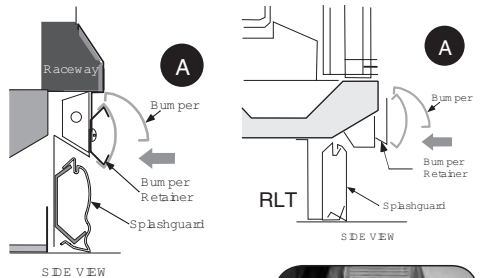
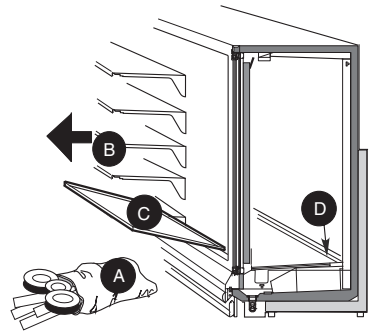
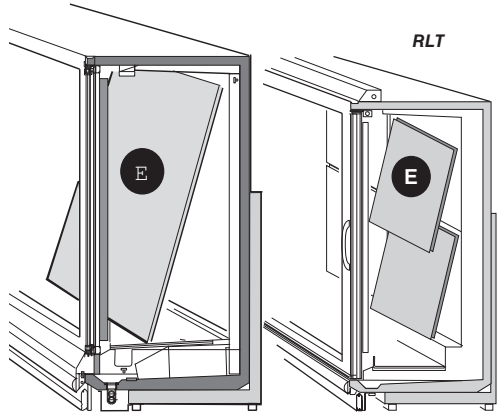

Figure 1. Prepare Cases

**RL / RM / RMF
RLN / RMN
and RLNI**

E. Remove back panels from ends to be joined by lifting up and out near the bottom. No tools are necessary. The RLT models have upper and lower back panels that must be removed.



F. Remove joint molding from any door frames that will be joined to another case.



G. RLNI Only: Remove screws and interior top panel on both sides of the island case end to be joined (see Figure 1).



RLNI Only

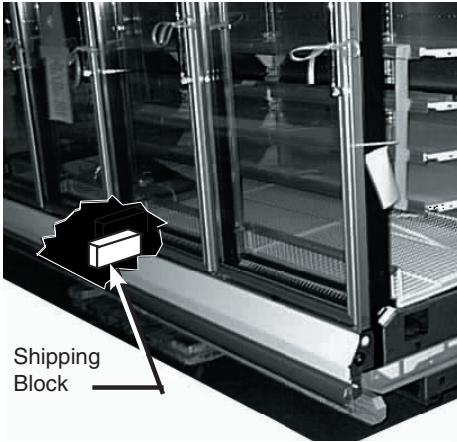

Figure 2. Remove Shipping Block
(One From Each Side of Island Models)

2 Locate and remove the shipping block in the center of the heat exchanger in the interior bottom of each case, see Figure 2.

Snap a chalk line on the floor to use as a guide for positioning the front of the cases in the line-up. The front base frame should be on the chalk line.

3 Once cases are close to final placement, remove the shipping braces from the ends to be joined, see Figure 3. Discard bolts and flat washers used to hold shipping braces. Bolts are too long to be used for joining.



DO NOT USE SHIPPING BOLTS TO JOIN CASES!

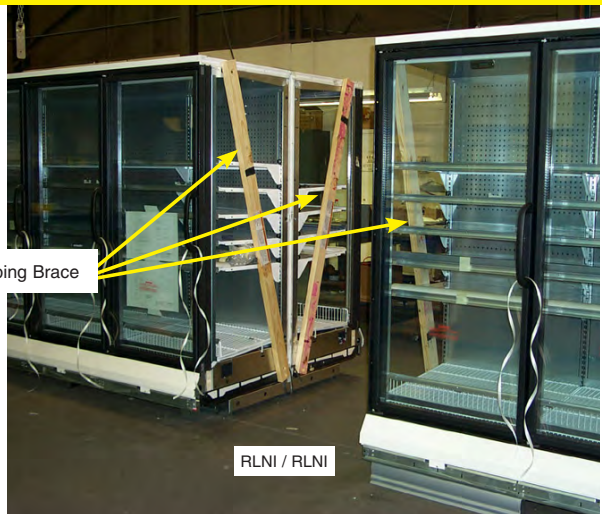

Figure 3. Remove Shipping Braces

4 If not already installed make sure Nut Retainers and Alignment Pins are in place in the right end frame as shown in Figure 4A or 4B.

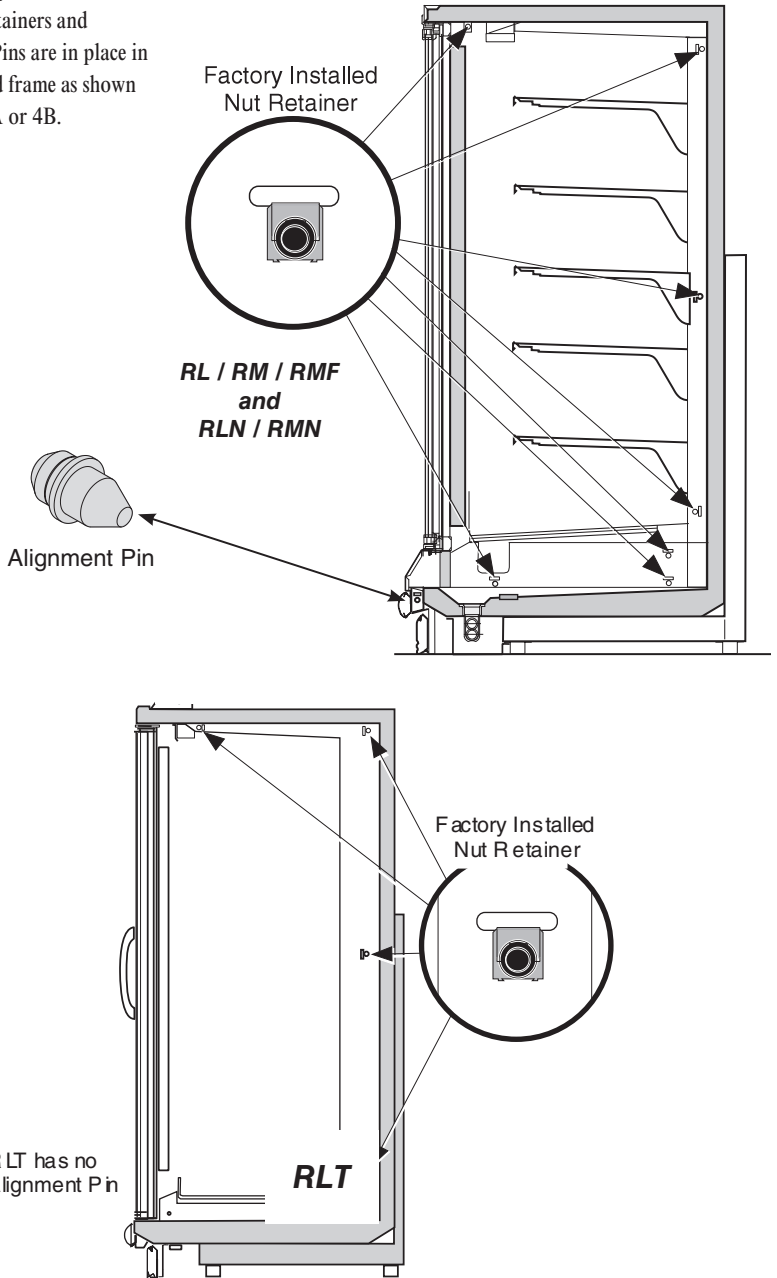
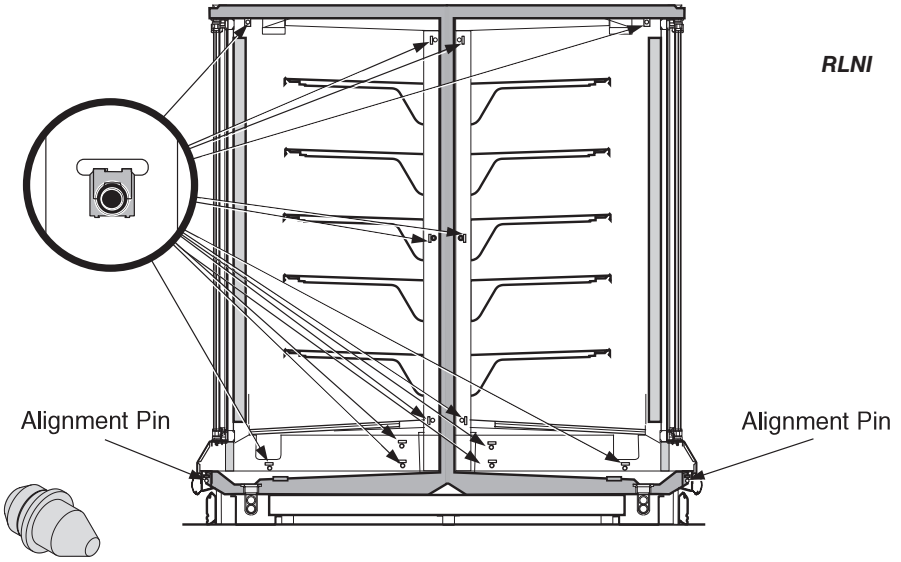

Figure 4A. Verify Nut Retainer Installation



5 Apply Donut Gasket – 1 in recess around both left end as shown in Figure 5A, Part 1; 5B or 5C, Part 1, and right end frames as shown in Figure 5A, Part 2; 5B or 5C, Part 2.

Apply the wider Foam Tape Gasket — 2 around the right end frame as shown in Figure 5A, Part 2, 5B or 5C, Part 2.

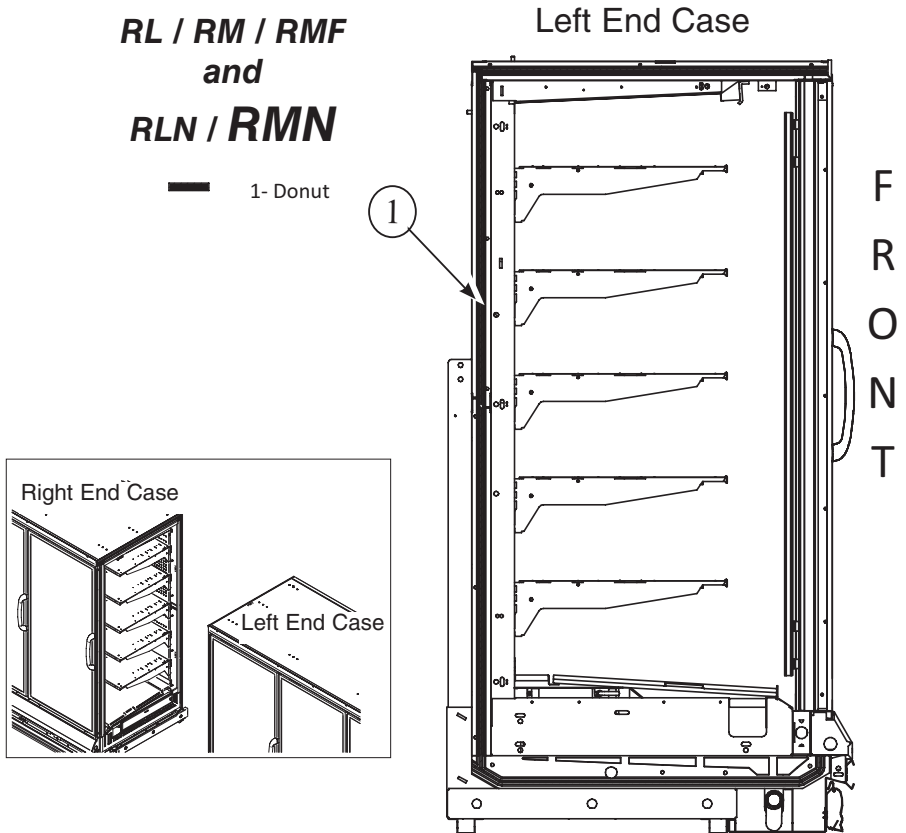





Figure 5A, Part 1. Apply Gasket to Left End of RL/RM/RMF and RLN/RMN

Apply Pad Shoe Sealer first, then apply the narrower Foam Tape Gasket — 3 around the perimeter of the right end frame outside of the donut gasket as shown in Figure 5A, Part 2, 5B or 5C, Part 2.

- Lap gaskets at lower corners.
 - Check that there are no gaps between gasket and case.
 - Do not stretch gasket, especially around corners.
- To make sharp corners, paper backing can be torn without removing from gasket.
- Do not butt gaskets; always lap

- joints.
- Remove paper backing after gasket is applied to keep gasket free of debris.
- Gasket has high tack adhesive and must be properly placed the first time.

-  1- Donut
-  2- 1 in x 1/2 in
-  3- 1/2 in x 1/4 in

**RL / RM /
RMF
and
RLN / RMN**

Use all three gaskets
When applying an end
assembly.

NOTES:

1. The perimeter gasket, ITEM 3, is required by NSF.
2. Butyl is NOT an acceptable substitute for donut or foam gasket.

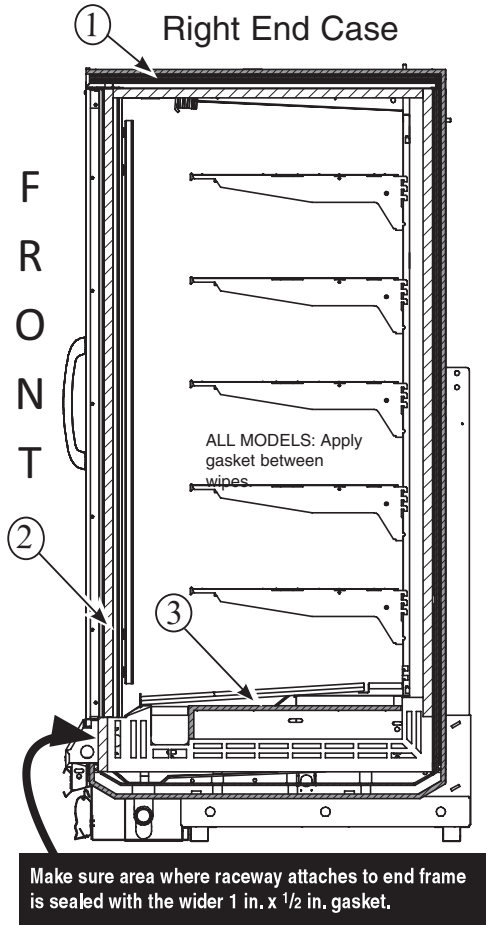

Figure 5A, Part 2. Apply Gaskets to Right End of RL/RM/RMF and RLN/RMN

RLNI

Left End Case

— (1) Donut

Gaskets
Must Be
Applied As
Shown

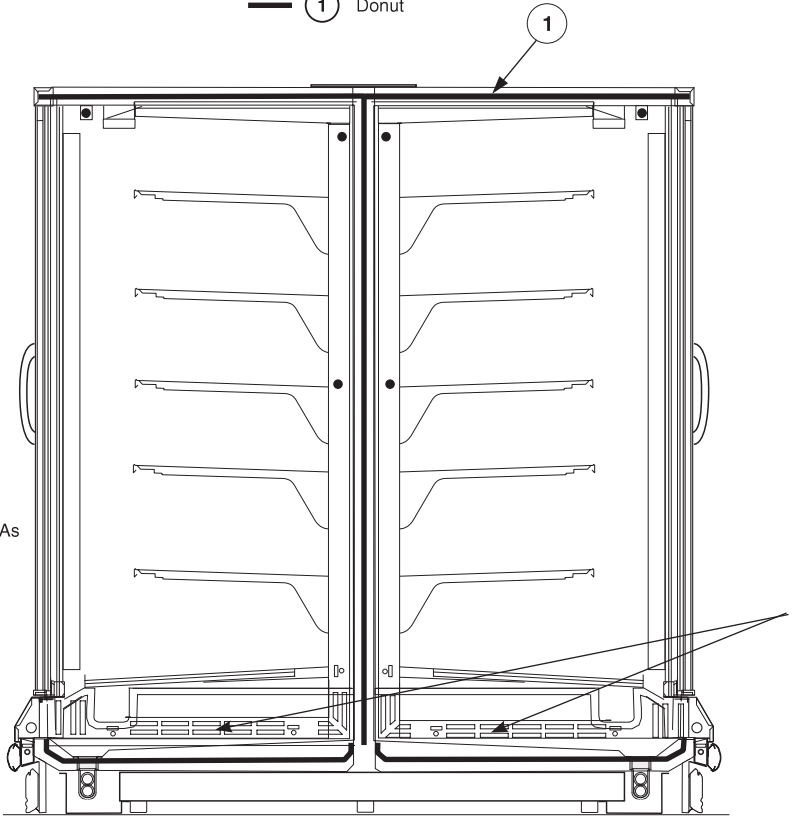

Figure 5A. Apply Gaskets to Left End of RLNI

RLNI

Right End Case

- Gaskets Must Be Applied As Shown
- 1 Donut
 - 2 1 in. x 1/2 in.
 - 3 1/2 in. x 1/4 in.

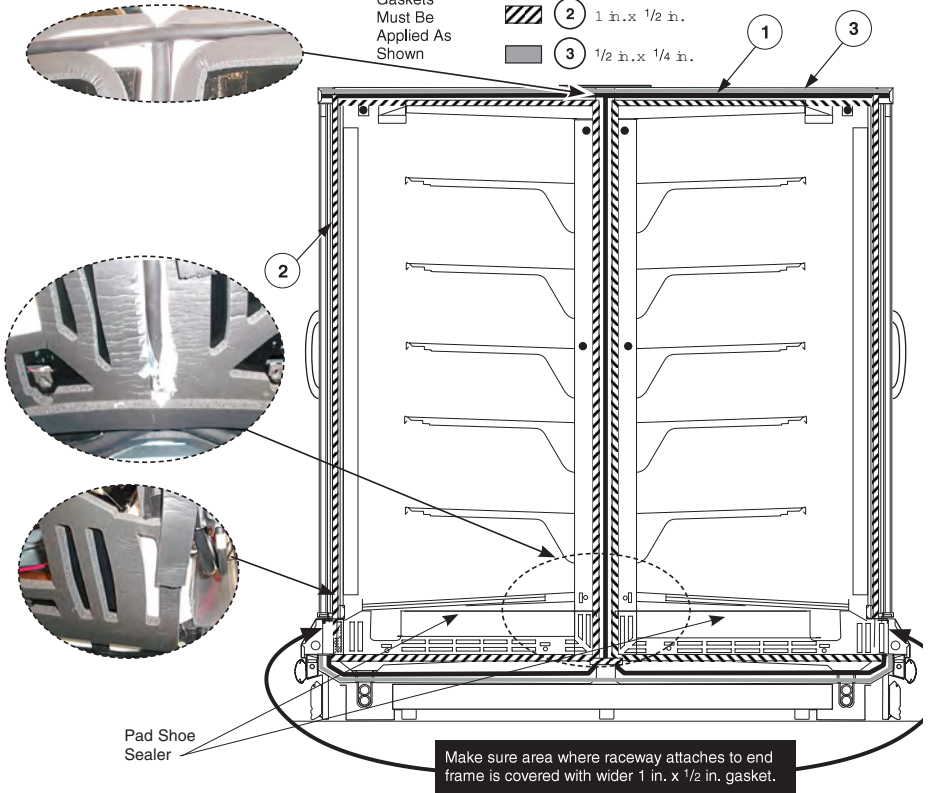

Figure 5B. Apply Gaskets to Right End of RLNI

RLT

Left End Case

1- Donut

1

F
R
O
N
T

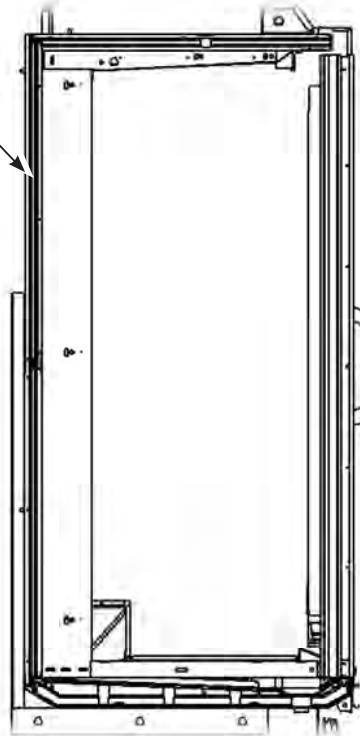
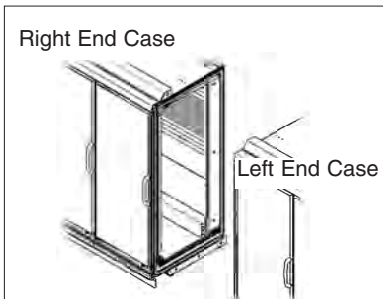





Figure 5C, Part 1. Apply Gasket to Left End of RLT

6 Move the second merchandiser against first, mating alignment pins with corresponding holes. Use care when pushing the cases together.

RL / RM / RLN / RMN / RLNI: Do not to cut wires routed along the front bumper retainer. See detail in Figure 6.

The RLT has no alignment pin and the wireway is at the top front.

RLT

-  1- Donut
-  2- 1 in x 1/2 in
-  3- 1/2 in x 1/4 in

Use all three gaskets
When applying an end assembly

Right End Case

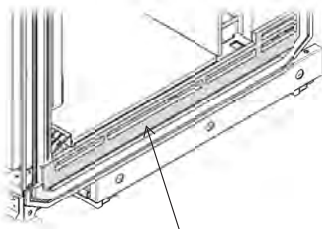

Pad Shoe Sealer

Apply Pad Shoe Sealer

F
R
O
N
T

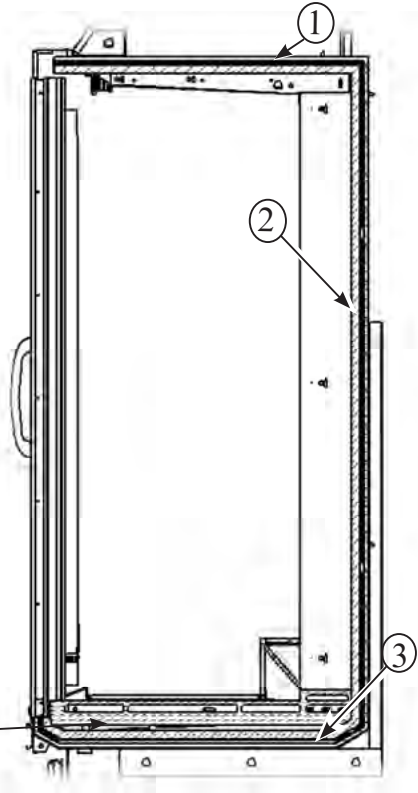

Figure 5C, Part 2. Apply Gasket to Right End of RLT

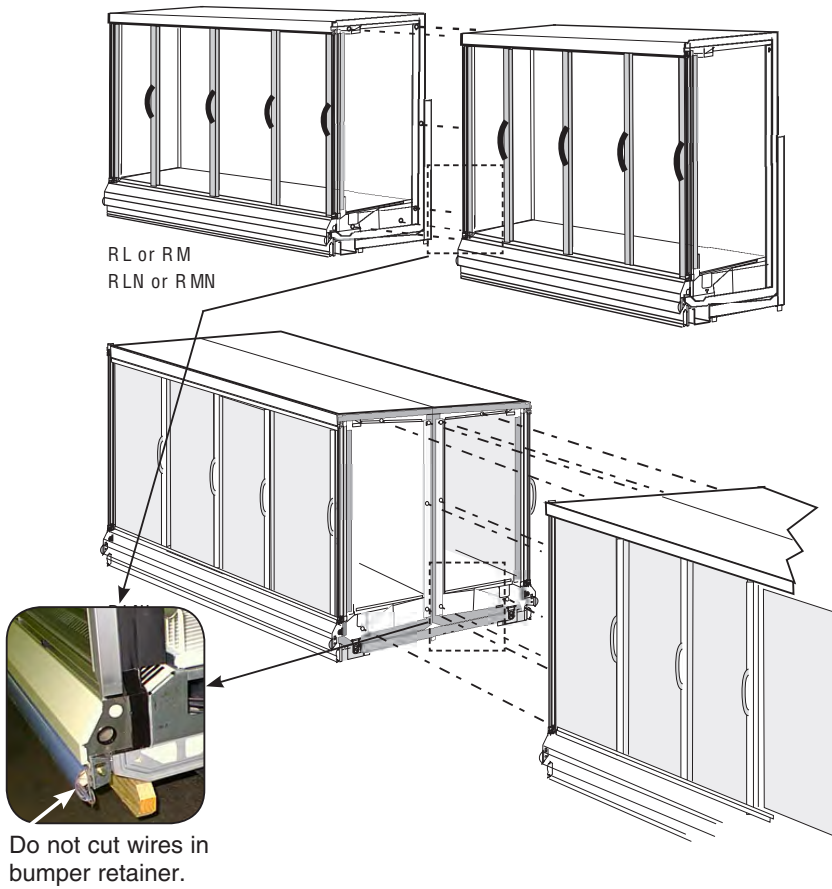

Figure 6. Move Cases Together

RL, RM, RMF, RLN, RMN

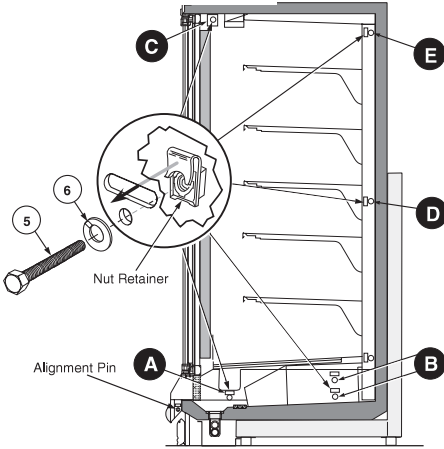

Figure 7A. Joining Sequence for RL, RM, RMF, RLN and RMN Cases

RLT

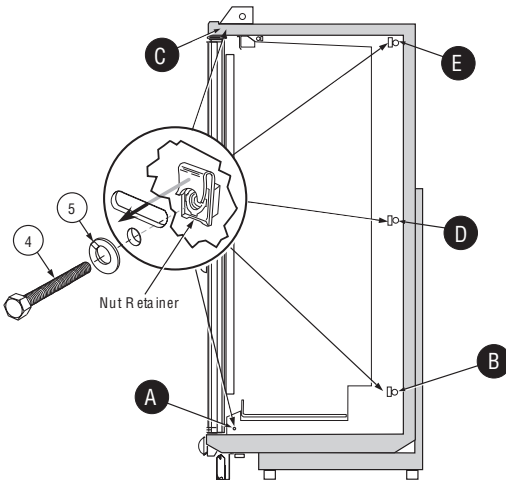

Figure 7B. Joining Sequence for RLT Cases

7 Loosely insert Cap Screw – 5 with Lock Washer – 6 into each nut retainer following the sequence shown in Figures 7A and 7B.

Do not tighten fully.

A. Fasten bottom fronts together, but tighten only until front panels touch.

B. Move to the bottom back position and join (2 places).

C. Join at the top front position.

D. Go to the middle back wall position and join.

E. Join at the lower back wall.

F. Finally, join at the top back wall position.

Following the same sequence, tighten each cap screw fully until the merchandisers are joined with a snug fit and gaskets are compressed.

When joining two RLNIE models, nut retainers and alignment pins are used on one case only.

8 Refer to Section 1 of the Reach-In Installation and Service Manual to install splashguard brackets and bumpers. Section 3 provides direction for installing splashguards, including splashguard

Splice Connector – 8. shown in Figure 9.

Note that RLT cases have steel splashguards that do not use a splice connector.

RLNI

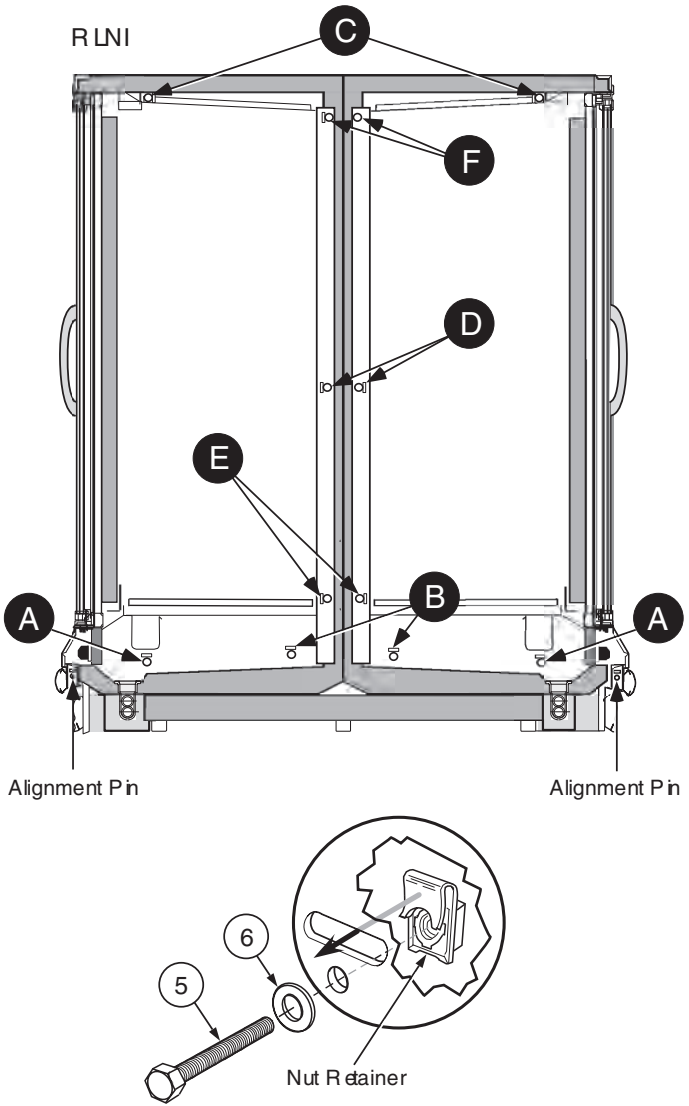

Figure 7C. Joining Sequence for RLNI Cases

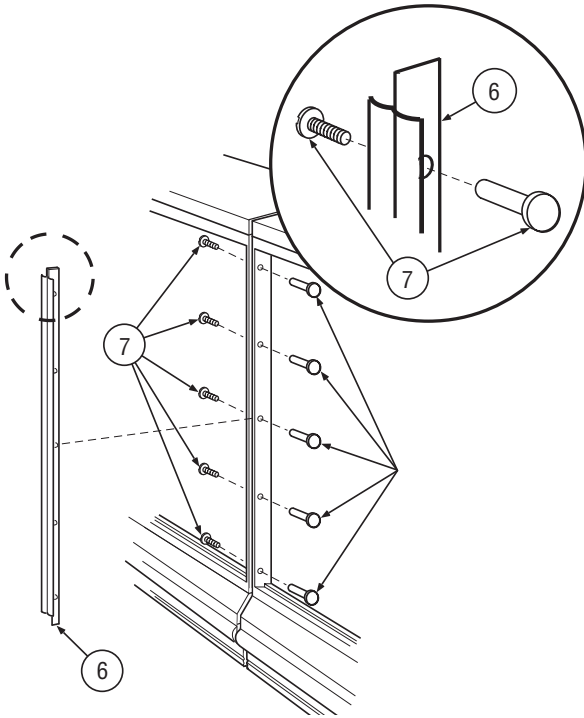

Figure 8. Installing "J" Molding

9 Align holes in frame with holes in Joint Molding – 6. Fasten cases together using Binder Post and Screws – 7 as shown in Figure 8.

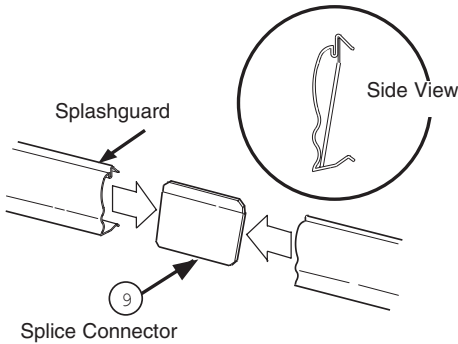

Figure 9. Installing Splashguard Splice Connector

10 Refer to Section 1 of the Reach-In Installation and Service Manual to install splashguard brackets and bumpers. Section 3 provides direction for installing splashguards, including splashguard

Splice Connector – 8, shown in Figure 9.

Note that RLT cases have steel splashguards that do not use a splice connector.

INSTALLING SPLASHGUARD BRACKETS

1. Attach splashguard retainer and splashguard retainer support to splashguard support bracket using two screws per bracket.

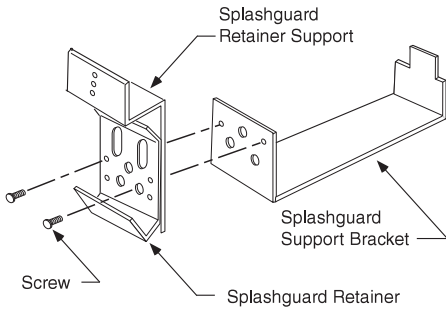

2. INSTALL SPLASHGUARD SUPPORT BRACKETS BEFORE PIPING CASE. The leveling brackets have a maximum extension of one (1) inch (25 mm) for uneven floors.

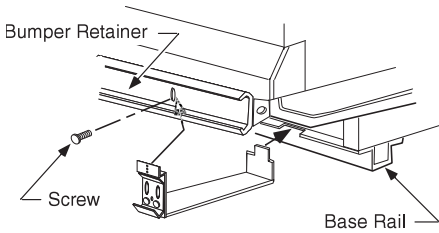

**DO NOT PLACE SHIMS UNDER
SPLASHGUARD BRACKETS.**

INSTALLING BUMPERS

Offsetting the bumpers and top rails helps to disguise the joint locations, giving the lineup a smoother look.

Begin at the left end of the line-up. A starter bumper is factory-installed with end kits. Insert the internal joint trim, then add the full-length bumper.

Align each bumper section with its retainer and push into place, working from the end of the lineup. Install full length bumpers and internal joint trims offset across joints. Make sure that no gaps exist between sections. Continue installing bumpers the length of the line up.

Do NOT install the last bumper sections at this time. These sections will be installed in the last step.

Once all except the last section of bumper have been installed, refrigerate the case line-up for at least six (6) hours. The last sections of bumper should be kept inside a refrigerated case or cooler during this time to allow the bumpers to contract.

Before installing the last full-length section, measure the remaining space. Use a miter box and fine-tooth saw to cut last bumper to length. Install the last section. Remove protective film from bumpers once installation is complete. Optional end bumpers are factory-installed.

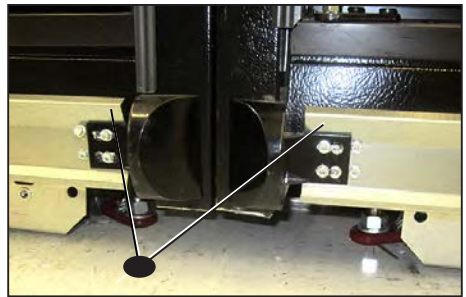
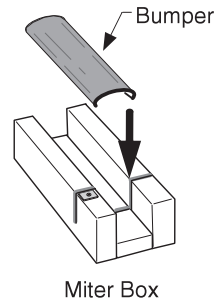
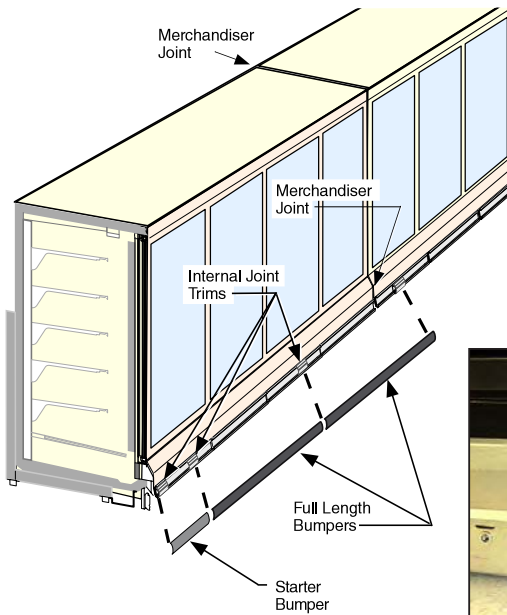

Bumper End Caps can be adjusted horizontally to eliminate gaps.

REFRIGERATION / ELECTRICAL

REFRIGERANT

The correct type of refrigerant will be stamped on each merchandiser's serial plate which is located on the left-hand end of the interior top liner.

WARNING

Refrigeration lines are under pressure. Depressurize and recover refrigerant before attempting any connection or repair.

Refrigerant vapor is hazardous to your health and can cause death. Avoid breathing refrigerant and lubrication vapor or mist. Exposure may irritate eyes, nose and throat. If accidental system discharge occurs, ventilate work area before resuming service.

Always wear safety goggles and protective gloves when working with refrigerants. Contact with refrigerant may cause injury. Disconnect hoses with extreme caution! All hoses may contain liquid refrigerant under pressure.

Be sure that any room where you are working is thoroughly ventilated, especially if a leak is suspected.

Read all safety information regarding the safe handling of refrigerant and refrigerant oil, including the Material Safety Data Sheet. MSDS sheets can be obtained from your refrigerant supplier.

CAUTION

When brazing pipes be sure to use the insulation blanket shipped with the merchandiser to prevent damage to the plastic case bottom.

REFRIGERANT PIPING

Standard Connection Location

The refrigerant line connections are at the right-hand end of merchandiser (end opposite the main serial plate) beneath the display pans. A sticker marks the location of the connection. The installer must saw a hole to exit the cases.

A refrigeration shroud ships with each case.

Before making connections, place the refrigeration shroud over refrigeration piping so that when the shroud is rotated into place, it will be in the upright position. The Figure 2-1 shows the correct orientation.

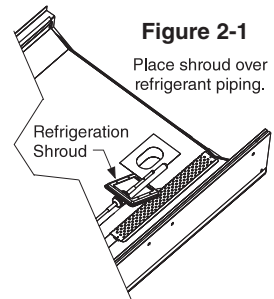

Be careful not to burn, scorch or overheat the shroud when making connections. Once connections have been made, apply silicone sealant to the bottom of the shroud as shown in Figure 2-2.

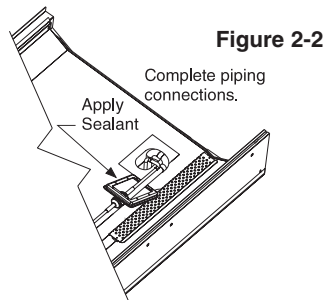

As shown in Figure 2-3, rotate and center the shroud over the refrigeration outlet foam pad.

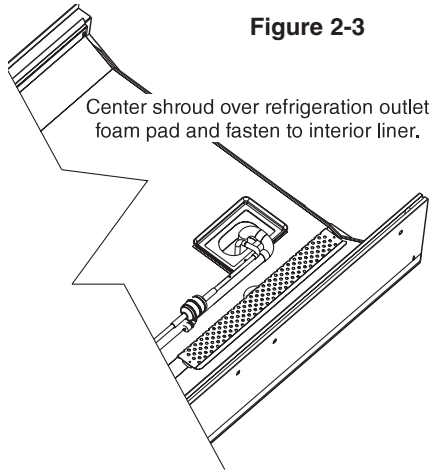

Seal this outlet thoroughly. Seal both the inside and the outside. We recommend using an expanding polyurethane foam insulation. Cover foam with silicone to prevent water from entering foam.

Optional Internal Top Piping Connections

A shroud should be used to seal outside pipe penetrations at the top of the merchandiser. Position the shroud over the case piping before making the final connection.

Once all connections are made and insulation has been applied to the piping, run a bead of sealant around the bottom of the shroud. Put the shroud into position and attach with six screws.

In the event the shroud was not placed over the piping prior to final connection, the shroud can be cut (carefully) and then installed with adhesive holding the shroud in place on top of the merchandiser.

After connections have been made, seal this outlet thoroughly. Seal both the inside and the outside. We recommend using an expanding polyurethane foam insulation. Cover foam with silicone to ensure seal around insulation and to prevent deterioration of foam.

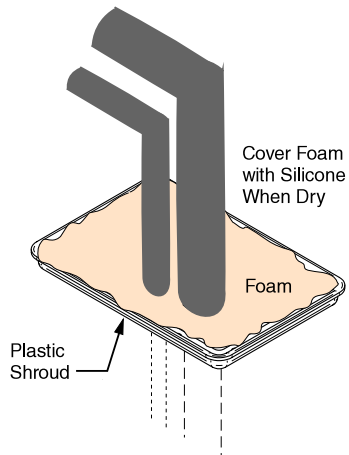
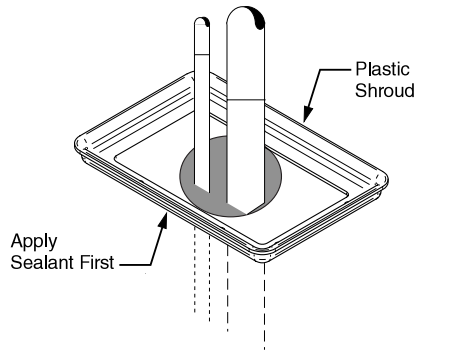

Multiplexing

Piping of merchandisers operating on the same refrigeration system may be run from merchandiser to merchandiser through the end frame saddles provided for this purpose. **DO NOT RUN REFRIGERANT LINES THROUGH MERCHANDISERS THAT ARE NOT ON THE SAME REFRIGERATION SYSTEM** as this may result in poor refrigeration control and compressor failure.

NOTE: If Gas defrost is used, the liquid line will need to be increased two sizes larger inside the merchandiser area. This is necessary to ensure even liquid drainage from all evaporators during defrost.

Line Sizing

Refrigerant lines should be sized as shown on the refrigeration legend that is furnished for the store or according to ASHRAE guidelines.

Oil Traps

P-traps (oil traps) must be installed at the base of all suction line vertical risers.

Pressure Drop

Pressure drop can rob the system of capacity. To keep the pressure drop to a minimum, keep the refrigerant line run as short as possible using a minimum number of elbows. Where elbows are required, **USE LONG RADIUS ELBOWS ONLY.**

INSULATION**With GAS Defrost**

The suction and liquid lines should **NOT** contact each other and should be insulated separately for a minimum of 30 ft (9144 mm) from the merchandiser.

With OTHER Than Gas Defrost

The suction and liquid lines should be clamped or taped together and insulated for a minimum of 30 ft (9144 mm) from the merchandiser.

With All Defrost

Additional insulation for the balance of the liquid and suction lines is recommended wherever condensation drippage is objectionable or the lines are exposed to ambient conditions.

CAUTION

The following information is applicable only for piping Hussmann merchandisers to Hussmann refrigeration equipment.

BRANCH LINE PIPING

Suction Line – All Defrosts

- Pitch in direction of flow.
- May be reduced by one size at one third of case run load and again after the second third. Do NOT reduce below evaporator connection size.
- Suction returns from evaporators enter at the top of the branch line.

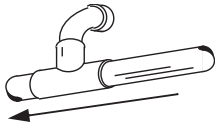

Suction Line Return

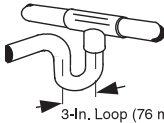

3-In. Loop (76 mm)

Liquid Line Take Off

Liquid Line – Off-time and Electric Defrost

- May be reduced by one size after one half the case load run. Do not reduce below evaporator connection size.
- Take-offs to evaporators exit the bottom of the liquid line. Provide an expansion loop for each evaporator take-off (minimum 3 in. (76 mm) diameter).

Liquid Line – Koolgas Defrost

- Maximum of 6 evaporators per Branch System.
- Increase the liquid line size inside the case by two sizes over the branch size.

Branch Size	In Case Size
1/2	7/8
5/8	1 1/8
7/8	1 3/8
1 1/8	1 5/8
1 3/8	2 1/8

- Take-offs to evaporators exit the bottom of the liquid line. Provide an expansion loop for each evaporator take-off (minimum 3 in. (76 mm) diameter).

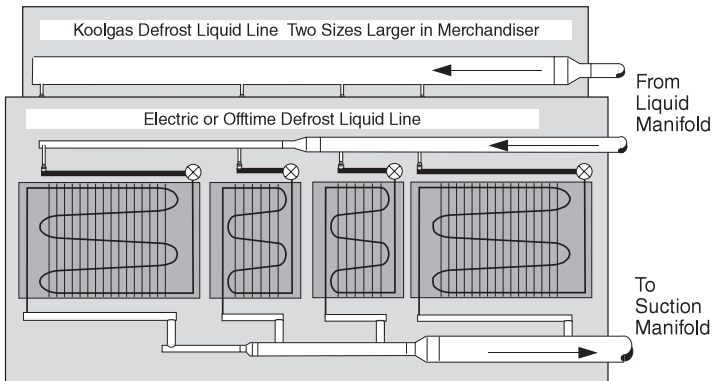

EXPANSION VALVE ADJUSTMENT

Expansion valves must be adjusted to fully feed the evaporator. Before attempting to adjust valves, make sure the evaporator is either clear or only lightly covered with frost, and that the merchandiser is within 10 deg F (6.5 deg C) of its expected operating temperature. Adjust valves as follows:

Attach two sensing probes (either thermocouple or thermistor) to the evaporator. Position one under the clamp holding the expansion valve bulb; securely tape the other to the coil inlet line.

Some "hunting" of the expansion valve is normal. The valve should be adjusted so that during the hunting THE GREATEST DIFFERENCE BETWEEN THE TWO PROBES IS 3-5 deg F (1.7-2.8 deg C). With this adjustment, during a portion of the hunting the temperature difference between the probes will be less than 3 deg F (1.7 deg C) and at times 0.

Make adjustments of no more than 1/4 turn for Balanced Port TEV and 1/2 turn at a time for other valve models. Wait at least 15 minutes before rechecking the probe temperature or making further adjustments.

REFRIGERATION THERMOSTAT

The thermostat body is located in the electrical raceway near the right-hand end of the merchandiser. Its sensing bulb is located behind the right end interior back panel.

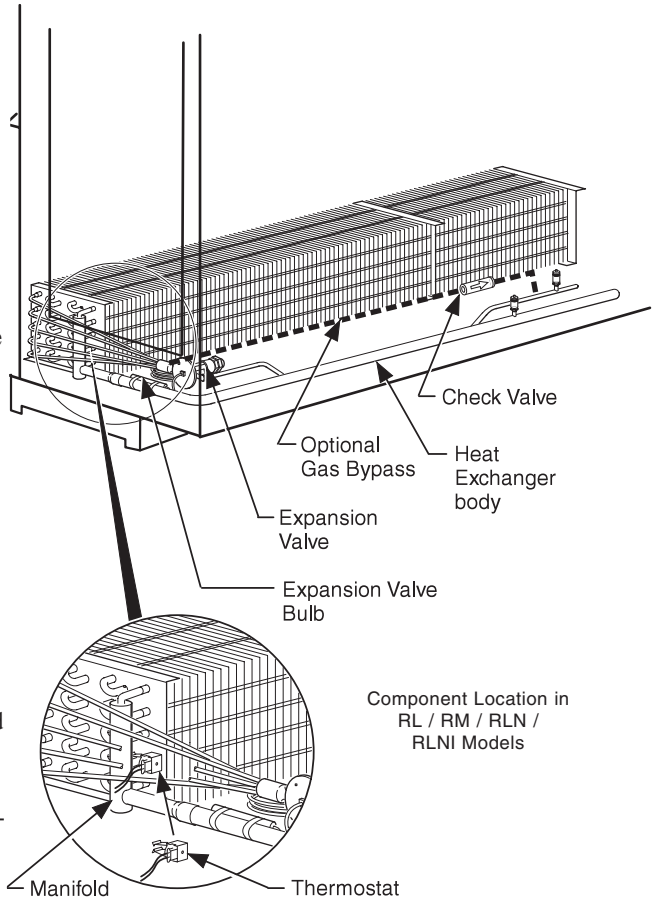

Component Location in RL / RM / RLN / RLNI Models

Component Location in RLT Models

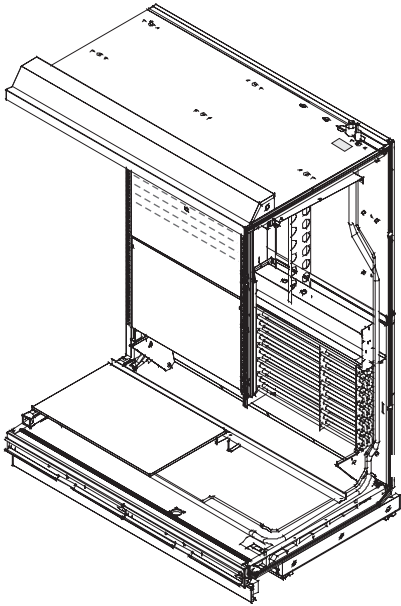

DEFROST TERMINATION THERMOSTAT

The standard disc type defrost termination thermostat is not adjustable.

On low-temperature merchandisers, the defrost termination thermostat or optional termination sensor is located on the right end of the coil at the bottom center return bend. If an optional adjustable thermostat is used, the bulb will be clamped to the suction line on the left end of the merchandiser.

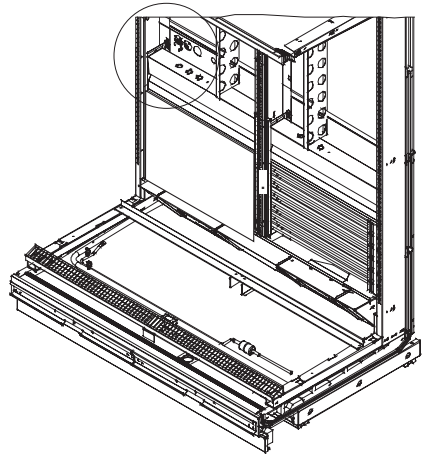
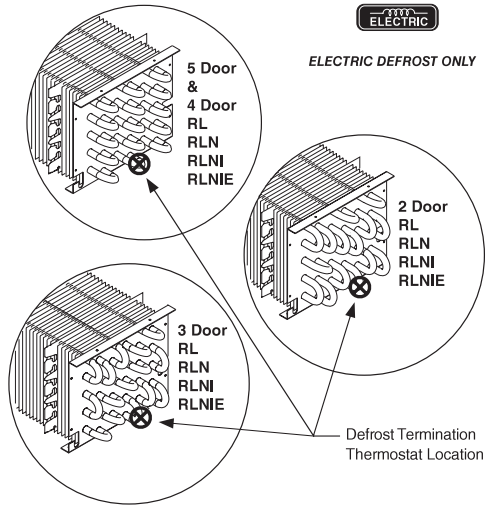
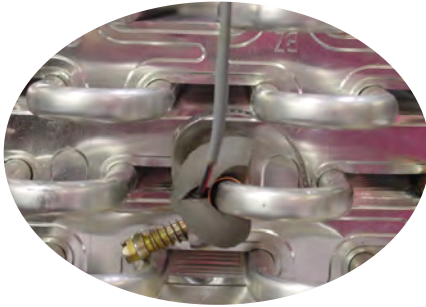

CONTROL SETTINGS MEDIUM TEMPERATURE

Conventional Single Compressor
Measure Discharge Air Temperature
at the center of the case
at the discharge honeycomb.

Merchandise temperature must be controlled by a thermostat or other device with a 3–6 deg F (1.7–3.3 deg C) differential. It will be wired to control the compressor motor contactor.

Standard Off Time defrost is time terminated. On outdoor units the defrost timer will control a liquid line solenoid beginning a defrost pumpdown 4 minutes before defrost.

The defrost frequency and lengths listed may require adjustment for specific store conditions. Factors include:

- Store temperature and humidity
- Low head pressure
- Long refrigerant line runs
- Seasonal changes
- Merchandise temperature lower than recommended

When practical, defrost when store is closed.

Low pressure control settings are applicable to outdoor condensing units where ambient does not fall below 0 deg F.

CONTROL SETTINGS LOW TEMPERATURE

Conventional Single Compressor
Measure Discharge Air Temperature
at the center of the case
at the discharge honeycomb.

Merchandise temperature must be controlled by a thermostat or other device with a 3–6 deg F (1.7–3.3 deg C) differential. It will be wired to control the compressor motor contactor.

Standard Electric defrost is temperature terminated. The defrost termination thermostats for all the merchandisers on one compressor are wired in series. Failsafe must not control defrost cycle length, especially when less than 208V power supply is used for defrost heaters, or if frost build up is heavy from shopping demands.

On outdoor units the defrost timer will control a liquid line solenoid beginning a defrost pumpdown 4 minutes before defrost.

Optional Gas defrost is time terminated and has fan cycling thermostat. The defrost frequency and lengths listed may require adjustment for specific store conditions.

Factors include:

- Store temperature and humidity
- Low head pressure
- Long refrigerant line runs
- Seasonal changes
- Merchandise temperature lower than recommended

Defrost after store closes when practical.

Low pressure control settings are applicable to outdoor condensing units where ambient does not fall below 0 deg F.

**CONTROL SETTINGS
MEDIUM TEMPERATURE**

Parallel Compressor Rack
Measure Discharge Air Temperature
at the center of the case
at the discharge honeycomb.

Merchandiser temperature must be controlled by a mechanical or electronic pressure regulator or thermostat that will be mounted on the rack.

Standard Off Time defrost is time terminated. The defrost frequency and lengths listed may require adjustment for specific store conditions. Factors include:

- Store temperature and humidity
- Low head pressure
- Long refrigerant line runs
- Seasonal changes
- Merchandiser temperature lower than recommended

Stagger defrosts to maintain stable compressor loading and sufficient defrost gas. When practical, defrost when store is closed.

**CONTROL SETTINGS
LOW TEMPERATURE**

Parallel Compressor Rack
Measure Discharge Air Temperature
at the center of the case
at the discharge honeycomb.

Merchandiser temperature must be controlled by a mechanical or electronic pressure regulator or thermostat that will be mounted on the rack.

Standard Electric defrost is temperature terminated. Failsafe must not control defrost cycle length, especially when less than 208V power supply is used for defrost heaters, or if frost build up is heavy from shopping demands.

Optional Gas defrost is time terminated and has fan cycling thermostat. The defrost frequency and lengths listed may require adjustment for specific store conditions. Factors include:

- Store temperature and humidity
- Low head pressure
- Long refrigerant line runs
- Seasonal changes
- Merchandiser temperature lower than recommended

Stagger defrosts to maintain stable compressor loading and sufficient defrost gas. When practical, defrost when store is closed.

MERCHANDISER ELECTRICAL DATA

Merchandiser data sheets for specific models are shipped with this manual. The data sheets provide merchandiser electrical data, standard electrical schematics, parts lists and performance data. Refer to the merchandiser data sheets and merchandiser serial plate for electrical information. Refer to the separate wiring diagrams shipped with the case for specific information about the merchandiser and any optional wiring kits that may have been applied.

FIELD WIRING

Field wiring must be sized for component amperes stamped on the serial plate. Actual ampere draw may be less than specified. Field wiring from the refrigeration control panel to the merchandisers is required for defrost termination thermostats and for optional refrigeration thermostats. When multiple merchandisers are on the same defrost circuit, the defrost termination thermostats are wired in series.

**ALWAYS CHECK THE
SERIAL PLATE FOR
COMPONENT AMPERES.**

Electric Defrost is standard for low temperature merchandisers and requires temperature termination. Gas defrost is optional. Off Time Defrost is standard for medium temperature merchandisers and is time terminated.

When two or more merchandisers with full length wireways are installed in line, remove the splashguards, end caps and wireway covers, and install the nipple and nuts (supplied) providing electrical passage from one merchandiser to the next. Following NEC and local codes is the responsibility of the electrical contractor.

ELECTRICAL CONNECTIONS

All wiring must be in compliance with NEC and local codes. All electrical connections are to be made to the terminal blocks in the electrical wireway behind the lower front panel at the right-hand end of the merchandiser (facing front).

IDENTIFICATION OF WIRING

Leads for all electrical circuits are identified by colored plastic bands. These bands correspond to the color code sticker (shown below) located inside the merchandiser wireway.

**WARNING**

Terminal block NOT for case-to-case wire connection.

WIRING COLOR CODE

Leads for all electrical circuits are identified by a colored plastic band: neutral wire for each circuit has either White insulation or a White plastic sleeve in addition to the color band.

**PINK REFRIG. THERMOSTAT LOW TEMP.
LIGHT BLUE. REFRIG. THERMOSTAT NORM TEMP.
DARK BLUE. DEFROST TERM. THERMOSTAT
PURPLE ANTI-SWEAT HEATERS
BROWN FAN MOTORS
GREEN* GROUND**

**ORANGE OR
TANLIGHTS
MAROON ..RECEPTACLES
YELLOW*..DEFROST HEATERS, 120V
RED*DEFROST HEATERS, 208V**

***EITHER COLORED SLEEVE OR COLORED INSULATION
ELECTRICIAN NOTE: Use copper conductor wire only.
CASE MUST BE GROUNDED**

THESE ARE MARKER COLORS WIRES MAY VARY.

DRIP PIPING AND SPLASHGUARDS

WASTE OUTLET AND WATER SEAL

The waste outlet location varies for each of the 1, 2, 3, 4, and 5-door merchandisers. Drip piping is located between the front merchandiser base and the splashguard fixture and runs parallel to the merchandiser (see Data Sheet for exact locations).

INSTALLING DRIP PIPING

Poorly or improperly installed drip pipes can seriously interfere with the merchandiser's operation and result in costly maintenance and product losses. Please follow the recommendations listed below when installing drip pipes to ensure proper installation.

- Never use drip piping smaller than the nominal diameter of the pipe or water seal supplied with the merchandiser.
- When connecting drip piping, the water seal must be used as part of the drip piping to prevent air leakage or insect entrance. Never use two water seals in series in any one drip pipe. **DOUBLE WATER SEALS IN SERIES WILL CAUSE AN AIR LOCK AND PREVENT DRAINING.**
- Pitch the drip piping in the direction of flow. There should be a minimum pitch of $\frac{1}{4}$ in. per ft (20 mm per 1 m).
- Avoid long runs of drip piping. Long runs make it impossible to provide the pitch necessary for good drainage.

CAUTION

Splashguard brackets MUST be installed before piping merchandiser.

(See Page 1-3)

Provide a suitable air break between flood rim of the floor drain and outlet of drip pipe. To meet code on low base merchandisers, it may be necessary to install a field-supplied drip pipe reducer. An alternative is to cut the last section of drip pipe at an angle.



- Prevent drip pipes from freezing sweating or freezing:
 - A. Do NOT install drip pipes in contact with uninsulated suction lines. Suction lines should be insulated with a non-absorbent insulation material.
 - B. Where drip pipes are located in dead air spaces, such as between merchandisers or between a merchandiser and a store wall, provide means to prevent drip pipe from sweating. External ventilation fans may be required to prevent sweating.

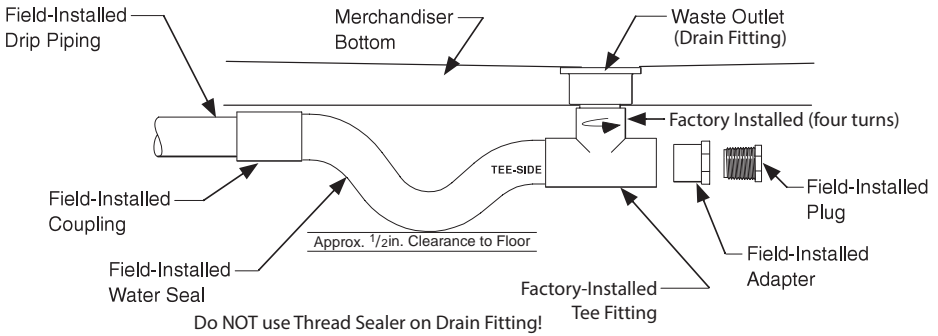

1. Tee is factory-installed. Do not overtighten threads, or the drain fitting or tee may become damaged.
2. Do NOT use thread sealer on ABS drain fitting. If sealer is used the ABS drain fitting may crack or leak! (If a tee needs to be installed it should be tightened no more than 4 turns.) Do not overtighten threads.

NOTE: It may be necessary to rotate water seal (trap) inside the tee a few degrees to ensure clearance at two locations. There must be clearance 1) between the bottom of the water seal and the floor, and 2) between the top of the water seal outlet and the bottom of the merchandiser. Do not over-rotate or gravity seal may be compromised. Always rotate trap bottom toward merchandiser support rail.

2. Dry fit the supplied water seal / trap to ensure approximately $\frac{1}{2}$ in. of clearance from the bottom of the trap to the floor as shown.

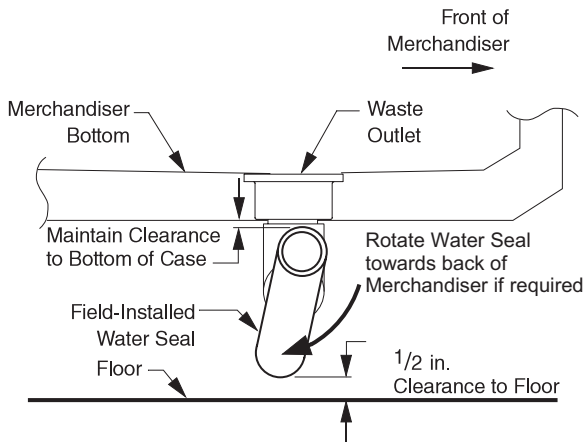

3. Install remaining PVC drain parts using recommended PVC cleaner, primer and cement per manufacturer's recommendations.
4. Thread plug into the adapter until snug but not to exceed four full rotations.
5. Installed drip piping may require additional support depending on the number and location of the hub floor drains. The installer should always provide adequate support to all drip piping arrangements to prevent excess stress on all drip piping components. The installer must provide additional support when "evac" type waste water systems are applied.

It is the installing contractor's responsibility to consult local agencies for local code requirements.

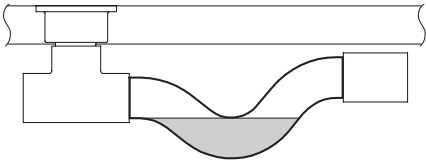

**Water Seal
Correct**

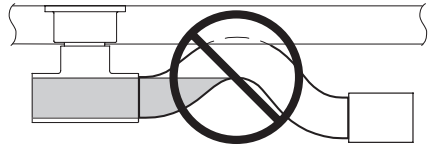

**Water Seal
NOT Correct**

DRIP PIPING LINEUP ARRANGEMENTS

The following illustrations below show typical arrangements for installing drip pipes for a lineup of merchandisers. Illustrations are for reference only. Piping may vary with location and access to hub drain(s). Each merchandiser waste outlet must be individually piped to a hub drain if $\frac{1}{4}$ in. drip piping pitch cannot be maintained.

NOTE: No more than two merchandiser are to be piped per water seal. Do not install water seal between two merchandiser waste outlets that are piped together. **(Double water seals in series will cause an air lock and prevent drainage.)**

RL, RLN Single Line Up (4 merchandisers shown)

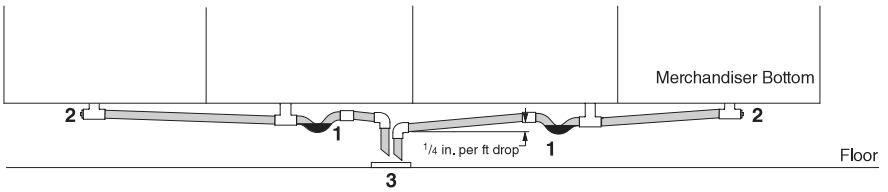

RL, RLN Single Line Up (4 merchandisers shown)

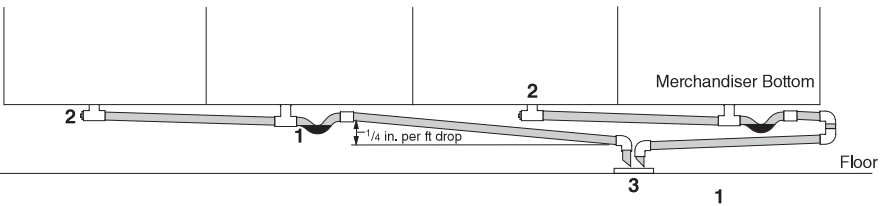

RLNI Cross Drip Piping (4 merchandisers shown)

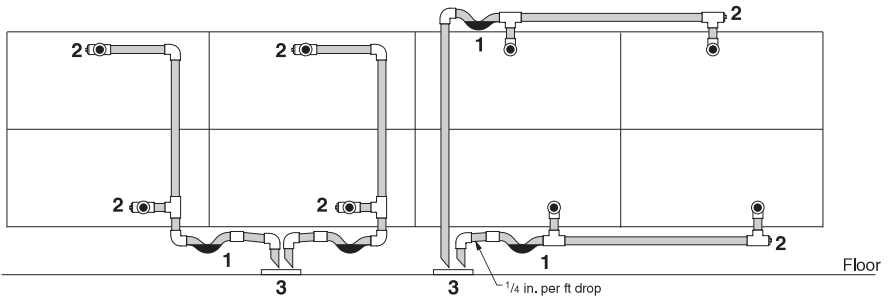

1 = Water Seal 2 = Clean Out Plug 3 = Hub Drain

INSTALLING SPLASHGUARDS

The splashguard is shipped inside each merchandiser. AFTER merchandisers have been leveled and joined, and all drip piping, electrical and refrigeration work has been completed, re-install the front color panel, then install the splashguards.

First, position top of splashguard over the top edge of the bracket; second, push the lower edge of the splashguard toward the bottom of the bracket until it

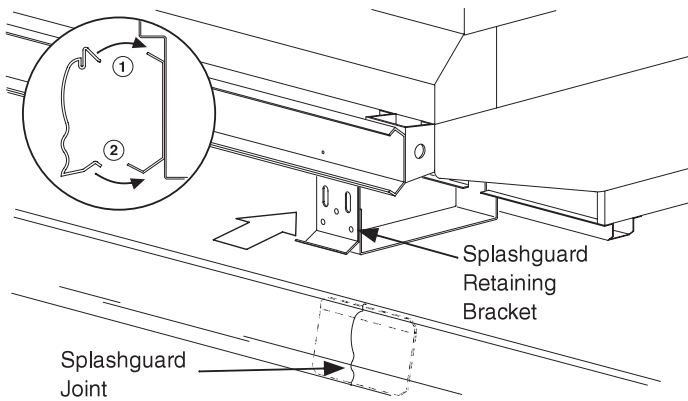

snaps into place.

Splashguards are joined with a galvanized metal splice connector that comes with the joint kit. Join the splashguards before installing on case.

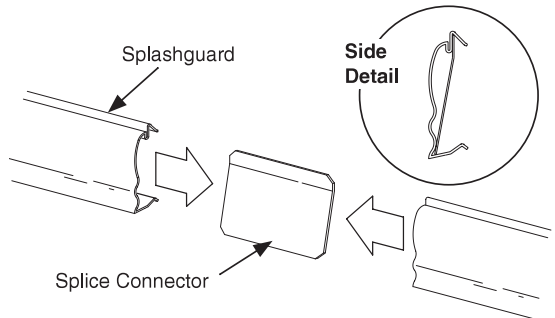

SEALING SPLASHGUARD TO FLOOR

IF REQUIRED by local sanitation codes, or if desired by the customer, plastic splashguards may be sealed to the floor using silicone type sealer. The amount needed will depend on how much the floor is out of level.

- Remove all dirt, wax and grease from the area of the splashguard where adhesion will be necessary. This is to ensure a good, secure installation.
- Apply a good silicone type sealer along the bottom of the splashguard. Sealant must be removed and replaced when servicing.

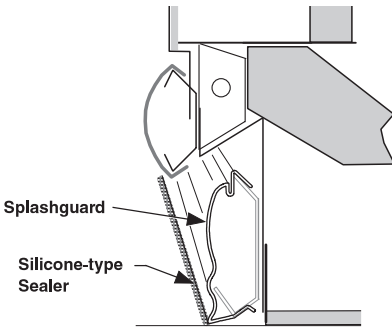

OPTIONAL stainless steel splashguards may be sealed to the floor using a vinyl cove base trim. The size of trim needed will depend on how much the floor is out of level.

To install the trim to the splashguard:

- Remove all dirt, wax and grease from the area of the splashguard where adhesion will be necessary. This is to ensure a good and secure installation.
- Apply a good contact cement to the cove trim and allow proper drying time according to the directions supplied with the cement.
- Install the trim to the splashguard so that it is lying flush with the floor. **DO NOT SEAL THE TRIM TO THE FLOOR.**
- **If required by local health codes** Cove Trim may be sealed to the floor using a silicone type sealer. Sealant must be removed and replaced when servicing.

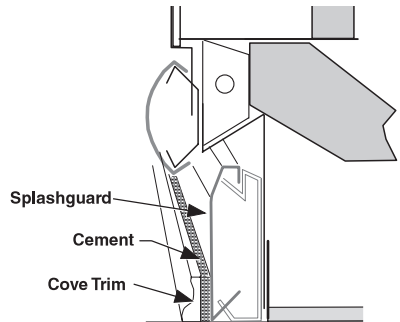

START UP / OPERATION

STARTUP

See the merchandiser's Technical Data Sheet for refrigerant settings and defrost requirements. Bring merchandisers down to the operating temperatures listed on the data sheet.

STOCKING

Product should NOT be placed in merchandisers until all refrigeration controls have been adjusted and merchandisers are at proper operating temperature.

All shelves and the lower deck are intended to display product. Shelf height is adjustable in one inch increments. Spacing of 12 inches is recommended for most applications. Maximum load per shelf is 170 pounds. Merchandisers may be ordered with optional "L" shaped wire shelves.

Proper rotation of product during stocking is necessary to prevent product loss. Always bring the oldest product to the front and set the newest to the back.

AIR DISCHARGE AND RETURN FLUES MUST REMAIN OPEN AND FREE OF OBSTRUCTION AT ALL TIMES to provide proper refrigeration and air curtain performance. Do not allow product, packages, signs, etc. to block these grilles. Do not use non-approved shelving, baskets, display racks, or any accessory that could hamper air curtain performance.

Do not prop doors open while stocking. And keep the doors closed as much as possible to prevent coil frosting and high merchandiser temperature.

**Hussmann recommends
solid shelves for ice cream.**

LOAD LIMITS

Shelf life of perishables will be short if load limit is violated. AT NO TIME SHOULD MERCHANDISERS BE STOCKED BEYOND THE LOAD LIMITS INDICATED.

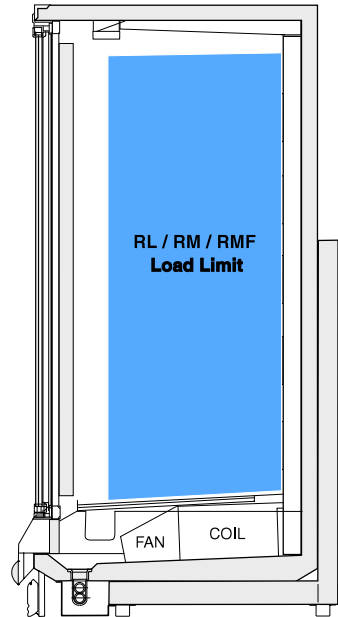

DO NOT BLOCK HONEYCOMB.



CAUTION

**Do not store items or flammable
materials atop the unit.
Do not walk on case.**

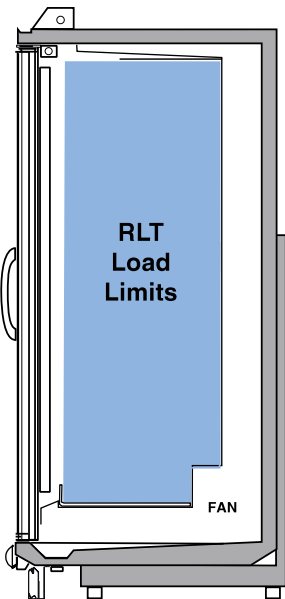
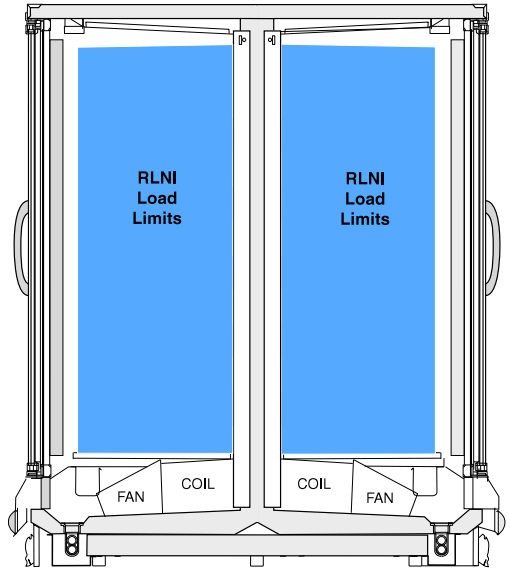
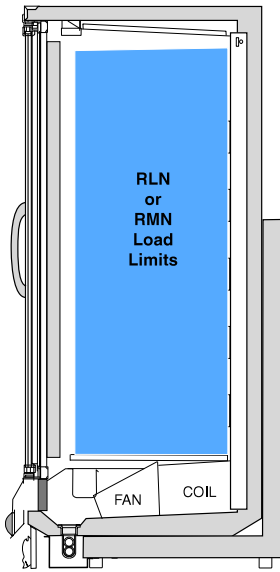

INSTALLING FDA/NSF REQUIRED THERMOMETER

The following pages provide the same information that ships with the thermometer.

This requirement does not apply to display refrigerators intended for bulk produce (refer to Page 1-1).

Please note that the tape cannot be exposed after installation.

This is an NSF-7 & US FDA Food Code Required Thermometer

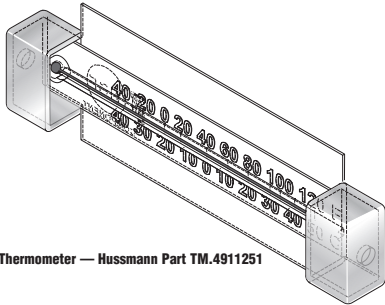

Thermometer — Hussmann Part TM.4911251

Hussmann Corporation • 12999 St. Charles Rock Road • Bridgeton, MO 63044-2483
U.S. & Canada 1-800-922-1919 • Mexico 1-800-522-1900 • www.hussmann.com
© 2007 Hussmann Corporation

Suggested Mounting Locations in Single Deck Glass Front Impact Merchandisers

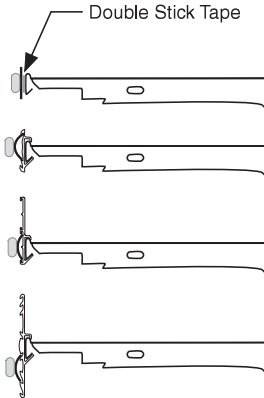
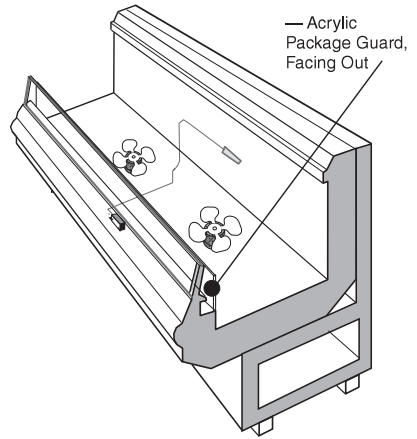

Flexible Plastic Fits in Price Tag Moldings

Hussmann P/N 0429971_C

10/2007

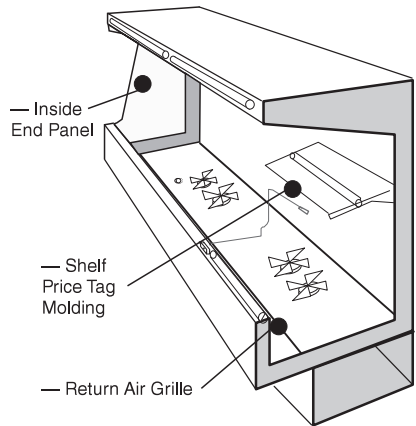

Suggested Mounting Locations in Multi-deck Merchandisers

Important – Please read!

This thermometer is provided in response to United States Food and Drug Administration (US FDA) Food Code [<http://www.fda.gov/>] and National Sanitation Foundation (NSF / ANSI) Standard 7 [<http://www.nsf.org/>]

Each installation will be different depending on how the unit is stocked, shopping patterns in the department and ambient conditions of the store. The suggested locations provided herein are possible locations. It is the responsibility of the purchaser / user to determine the location within the food storage area of the unit that best meets the code requirements above.

The thermometer may need to be moved several times to find the warmest location. Mounting options include flexible plastic for price tag molding application, magnet applied to back of flexible plastic for steel end wall, and double stick tape. Tape must not be exposed after installation.

Questions about either code should be addressed to local agencies or other appropriate officials.

Keep with merchandiser

or give to store manager.

DO NOT DESTROY.

MAINTENANCE

CARE AND CLEANING

Long life and satisfactory performance of any equipment is dependent upon the care it receives. To ensure long life, proper sanitation and minimum maintenance costs, these merchandisers should be thoroughly cleaned, all debris removed and the interiors washed down, weekly.

Fan Plenum

To facilitate cleaning, the fan plenum is hinged and also fastened with screws at each end. After cleaning be sure the plenum is properly lowered into position and that screws are reinstalled OR PRODUCT LOSS WILL RESULT due to improper refrigeration.



WARNING

**SHUT FANS OFF DURING
CLEANING PROCESS.**

Always*Clear™ Glass

Wipe inside of glass with isopropyl alcohol and a soft cloth. Allow surface to dry before closing door. Use of other cleaners or abrasives may damage the Always*Clear surface, and/or void the warranty. Refer to manual that ships with doors.



WARNING

Do NOT use HOT water on COLD glass surfaces. This can cause the glass to shatter and could result in personal injury. Allow glass fronts, ends and service doors to warm before applying hot water.

Interior Surfaces

The interior surfaces may be cleaned with most domestic detergents, ammonia based cleaners and sanitizing solutions with no harm to the surface.

Exterior Surfaces

The exterior surfaces should be cleaned with a mild detergent and warm water to protect and maintain their attractive finish. NEVER USE ABRASIVE CLEANSERS OR SCOURING PADS.

Do Not Use:

- Abrasive cleansers and scouring pads, as these will mar the finish.
- Coarse paper towels on coated glass.
- Ammonia-based cleaners on acrylic parts.
- Solvent, oil or acidic based cleaners on any interior surfaces.

Do Use:

- Remove the product and all loose debris to avoid clogging the waste outlet.
- Store product in a refrigerated area such as a freezer. Remove only as much product as can be taken to the freezer in a timely manner.
- **First turn off refrigeration, then disconnect electrical power.**
- Thoroughly clean all surfaces with soap and hot water. **DO NOT USE STEAM OR HIGH WATER PRESSURE HOSES TO WASH THE INTERIOR. THESE WILL DESTROY THE MERCHANDISERS' SEALING CAUSING LEAKS AND POOR PERFORMANCE.**
- Remove screws and lift hinged fan plenum for cleaning. **BE SURE TO REPOSITION THE FAN PLENUM AFTER CLEANING MERCHANDISER.**
- Take care to minimize direct contact between fan motors and cleaning or rinse water.
- Rinse with hot water, but do NOT flood. **NEVER INTRODUCE WATER FASTER THAN THE WASTE OUTLET CAN REMOVE IT.**
- Allow merchandisers to dry before resuming operation.
- After cleaning is completed, turn on power and refrigerant to the merchandiser.
- Verify that merchandiser is working properly.

**WARNING**

Product will be degraded and may spoil if allowed to sit in a non-refrigerated area.

CLEANING HONEYCOMB ASSEMBLIES

Honeycombs should be cleaned every six months. Dirty honeycombs will cause merchandisers to perform poorly. The honeycombs may be cleaned with a vacuum cleaner. Soap and water may be used if all water is removed from the honeycomb cells before reassembling. Be careful not to damage the honeycombs.

1. Remove the sheet metal screws located in the front metal retainer which holds the honeycomb assembly in place.
2. Lift the honeycomb assembly out of the L-bracket to remove it.
3. Clean and dry the honeycomb.
4. After cleaning, reassemble in reverse order of removal.

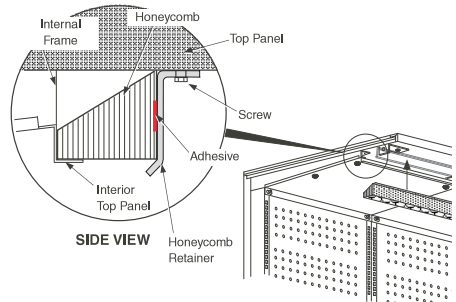

CLEANING STAINLESS STEEL SURFACES

Use non-abrasive cleaning materials, and always polish with grain of the steel. Use warm water or add a mild detergent to the water and apply with a cloth. Always wipe rails dry after wetting.

Use alkaline chlorinated or non-chlorine containing cleaners such as window cleaners and mild detergents. Do not use cleaners containing salts as this may cause pitting and rusting of the stainless steel finish. Do not use bleach.

Clean frequently to avoid build-up of hard, stubborn stains. A stainless steel cleaning solution may be used periodically to minimize scratching and remove stains. Rinse and wipe dry immediately after cleaning. Never use hydrochloric acid (muriatic acid) on stainless steel.

CLEANING COILS

NEVER USE SHARP OBJECTS AROUND COILS.

Use a **soft brush or vacuum brush to clean debris from coils.**

Do not puncture coils!

Do not bend fins. Contact an authorized service technician if a coil is punctured, cracked, or otherwise damaged.

Do NOT use chlorine or ammonia-based cleaners to clean aluminum coils.

ICE in or on the coil indicates the refrigeration and defrost cycle is not operating properly. Contact an authorized service technician to determine the cause of icing, and to make adjustments as necessary. To maintain product integrity, move all product to a cooler until the unit has returned to normal operating temperatures.



WARNING

Do NOT allow cleaning agent or cloth to contact food product.

CLEANING UNDER MERCHANDISERS

Remove splashguards not sealed to floor. Use a vacuum with a long wand attachment to remove accumulated dust and debris from under the merchandiser.

REMOVING SCRATCHES FROM BUMPER

Most scratches and dings can be removed using the following procedure.

1. Use steel wool to smooth out the surface area of the bumper or top rail.
2. Clean area.
3. Apply vinyl or car wax and polish surface for a smooth glossy finish.

NOTES:

SERVICE

REPLACING FAN MOTORS AND
BLADES

See cross section for location of evaporator fans. Should it ever be necessary to service or replace the fan motors or blades be certain that the fan blades are re-installed correctly.

For access to RL / RM / RLN / RMN / RLNI / RLNIE fans:

1. Turn off power.
2. Remove bottom display pans.
3. Disconnect fan from wiring harness.
4. Remove fan blade.
5. Remove screws holding fan motor/bracket assembly to plenum and remove assembly.
6. Replace fan motor/bracket assembly and reinstall screws.
7. Reinstall fan blade.
8. Reconnect fan to wiring harness.
9. Turn on power.
10. Verify that motor is working and blade is turning in the correct direction.
11. Close large air gaps under fan plenum. Warmer air moving into refrigerated air reduces effective cooling. If the plenum does not rest against the case bottom without gaps, apply foam tape to the bottom of the fan plenum to reduce improper air movement, however defrost water should not be blocked by fan plenum. Do NOT seal fan plenum so that water can not drain.
12. Replace display pans. Bring merchandiser to operating temperature before restocking.

 **WARNING**

Always disconnect the electrical power at the main disconnect when servicing or replacing any electrical component. This includes, but is not limited to, such items as fans, heaters, thermostats and lights.

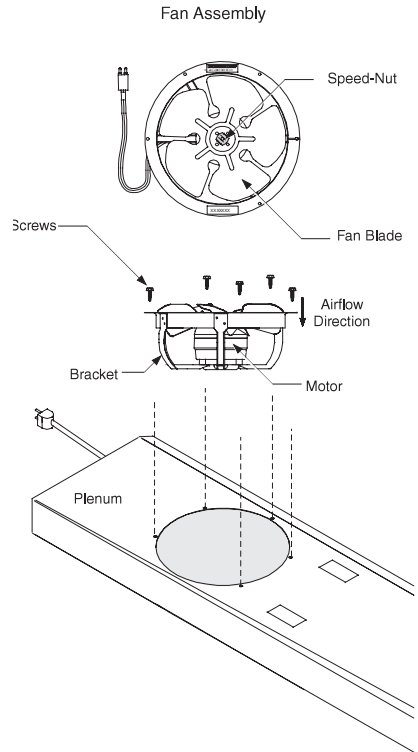

Hussmann recommends against frame heater cycling with Innovator doors to prevent door seals from freezing to the frames and tearing.

RLT ONLY

For access to these fans:

1. Turn off power.
2. Remove bottom display pans.
3. **Disconnect fan from wiring harness.**
4. Remove fan blade.
5. Lift fan plenum and remove screws holding bottom of motor to fan basket.
6. Replace fan motor and blade.
7. Lower fan plenum.
8. Reconnect fan to wiring harness.
9. Turn on power.
10. Verify that motor is working and blade is turning in the correct direction.
11. Close large air gaps under fan plenum. Warmer air moving into refrigerated air reduces effective cooling. If the plenum does not rest against the case bottom without gaps, apply foam tape to the bottom of the fan plenum to reduce improper air movement, however defrost water should not be blocked by fan plenum. Do NOT seal fan plenum so that water can not drain.
12. Replace display pans. Bring merchandiser to operating temperature before restocking.

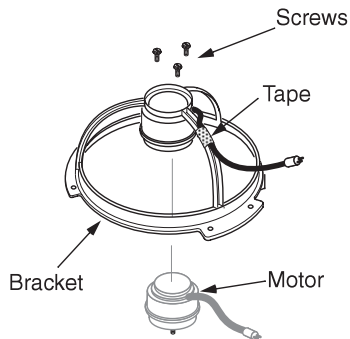
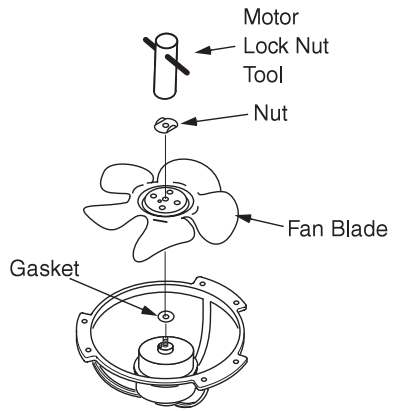
**WARNING**

Product will be degraded and may spoil if allowed to sit in a non-refrigerated area.

**WARNING**

Always disconnect the electrical power at the main disconnect when servicing or replacing any electrical component. This includes, but is not limited to, such items as fans, heaters, thermostats and lights.

REPLACING ELECTRIC DEFROST HEATERS FOR (RL/RLN/RLNI/RLNIE) ONLY

Electric defrost requires a heater on the front and rear of the coil as shown. The heaters are held in place by tabs in the coil brackets.

Front Defrost Heater

1. Disconnect Power.
2. Lift fan plenum up and back to access the heater.
3. Bend tabs holding heater to horizontal.
4. Remove heater from coil bracket.
5. Position new heater in bracket.
6. Bend tabs back to vertical to hold heater in bracket.

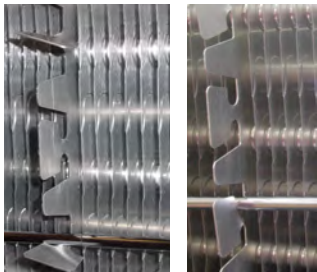
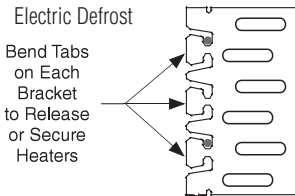

7. Replace the coil cover and lower fan plenum.
8. Turn on power.
9. Verify that heater is working correctly.
10. Close air gaps under fan plenum. Warmer air moving into refrigerated air reduces effective cooling. If the plenum does not rest against the case bottom without gaps, apply foam tape to the bottom of the fan plenum to reduce improper air movement. Use silicone sealant to close other gaps.
11. Replace display pans. Bring merchandiser to operating temperature before restocking.

Rear Defrost Heater

1. Disconnect Power.
2. Remove coil cover.
3. Remove clips holding heater to coil tube.
4. Remove heater from slots in coil bracket.
5. Position new heater in slots.
6. Replace clips.

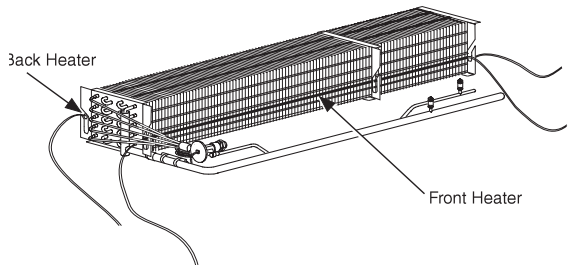

7. Replace the coil cover.
8. Turn on power.
9. Verify that heater is working correctly.
10. Replace display pans. Bring merchandiser to operating temperature before restocking.

4. Remove heater from bracket.
5. Position new heater in bracket.
6. Close the bracket with the element support
7. Turn on power.
8. Verify that heater is working correctly.

REPLACING Electric Defrost Heaters (RLT Only)

RLT electric defrost heaters are located under the coil as shown in the photo below. Mounting brackets and supports are attached to plenum brackets.

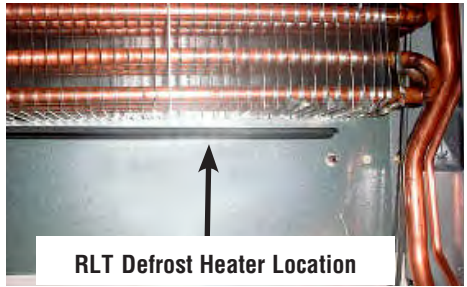

1. Disconnect Power.
2. Remove lower back panels to access the heater.
3. Lift fan plenum up and back to access the heater.

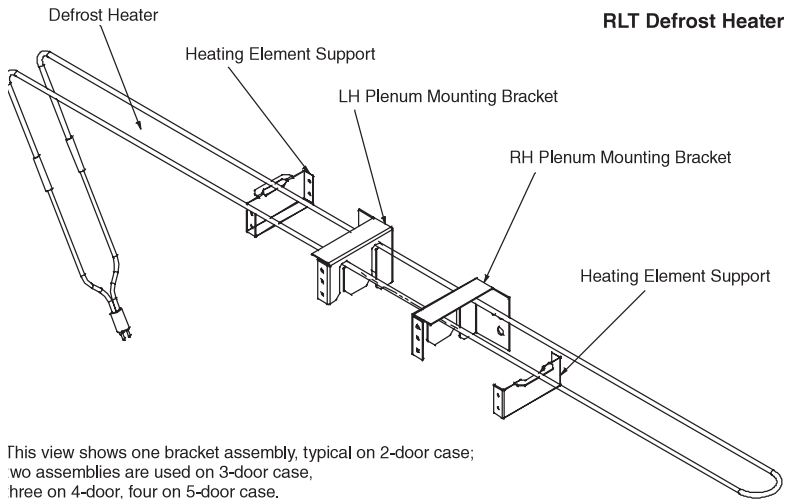

This view shows one bracket assembly, typical on 2-door case; two assemblies are used on 3-door case, three on 4-door, four on 5-door case.

REPLACING Drain Pan Heater — Electric and Gas Defrost (Low Temperature Only)

The drain pan heater is located as shown below.

Remove Drain Pan Heater

1. Disconnect power.
2. Pull heater out from under jiffy clips.
3. Position new heater under jiffy clips. Be sure offset is properly positioned around the drain.
If jiffy clips are removed, **make certain sealer is replaced.**
4. Reconnect power.
5. Verify that heater is working correctly.



WARNING

Always disconnect the electrical power at the main disconnect when servicing or replacing any electrical component. This includes, but is not limited to, such items as fans, heaters, thermostats and lights.

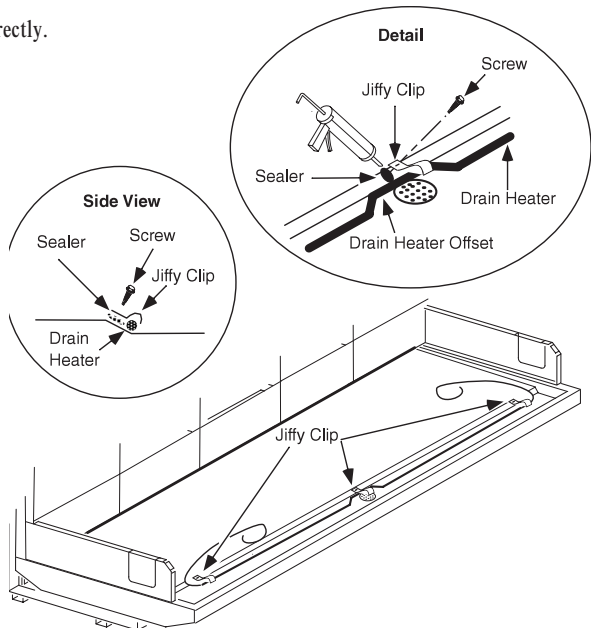

SERVICING VERTICAL LIGHTING

Refer to door manufacturer's manual for servicing of vertical lamps.

SERVICING DOORS AND FRAMES

See door manufacturer's service manual for servicing information. One manual is shipped with each merchandiser.

Hussmann's Innovator Door manual (P/N 0425683) can be found on the website WWW.HUSSMANN.COM.

REPLACING DOOR OR DOOR FRAME PARTS

Parts for Reach-in doors and door frame assemblies must be ordered direct from the door manufacturer. This includes the glass doors, door frame assemblies, lamps, ballasts, door handles, hold open slides, and power cords.

Refer to specific warranty supplied with the door.

The manufacturers have a warranty against moisture penetration, a warranty against tempered glass breakage, and a warranty on ballasts. Lamps are not covered by Hussmann or the door manufacturer.

REPLACING DAMAGED DRAIN FITTING

The following procedure is for the field repair of a broken drain fitting.

1. Use a drill with a 1⁷/₈-inch (48 mm) hole saw to drill out the bottom of the drain fitting. Be sure to drill completely through fitting and bottom liner.

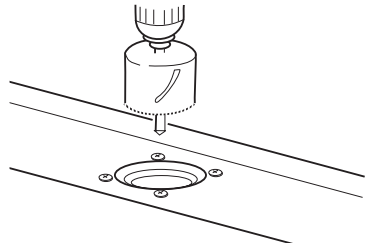

Drain Fitting Viewed from Inside Case

2. Insert adapter into drain fitting. **Do NOT use thread sealer on ABS drain fitting. If sealer is used the ABS drain fitting may crack or leak!** (Tee should be tightened no more than 4 turns.) Do not overtighten threads.

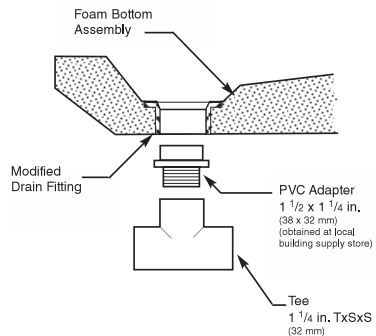

Do NOT use Thread Sealer on Drain Fitting!

End Section View

REPAIRING ALUMINUM COIL

The aluminum coils used in Hussmann merchandisers may be easily repaired in the field. Materials are available from local refrigeration wholesalers.

Hussmann recommends the following solders and technique:

Solders

Aladdin Welding Products Inc.
 P.O. Box 7188
 1300 Burton St.
 Grand Rapids, MI 49507
 Phone: 1-800-645-3413
 Fax: 1-800-645-3414

X-Ergon
 1570 E. Northgate
 P.O. Box 2102
 Irving, TX 75062
 Phone: 1-800-527-9916

NOTE:
 Hussmann Aluminum melts at 1125°F (607°C)

Aladdin 3-in-1 rod at 732°F (389°C)

X-Ergon Acid core at 455°F (235°C)

Technique:

1. Locate Leak.
2. REMOVE ALL PRESSURE.
3. Brush area UNDER HEAT.
4. Use PRESTOLITE TORCH ONLY. Number 6 tip.
5. Maintain separate set of stainless steel brushes and USE ONLY ON ALUMINUM.
6. Tin surface around area.
7. Brush tinned surface UNDER HEAT, thoroughly filling the open pores around leak.
8. Repair leak. Let aluminum melt solder, NOT the torch.
9. Don't repair for looks. Go for thickness.
10. Perform a leak check.
11. Wash with water.
12. Cover with a good flexible sealant.

HUSSMANN®

**To obtain warranty information
or other support, contact your
Husmann representative.
Please include the model and
serial number of the product.**

Husmann Corporation, Corporate Headquarters: Bridgeton, Missouri, U.S.A. 63044-2483 01 October 2012