

We reserve the right to change or revise specifications and product design in connection with any feature of our products. Such changes do not entitle the buyer to corresponding changes, improvements, additions or replacements for equipment previously sold or shipped.

Item	Part #	Description	Wiring Item #	Item	Part #	Description	Wiring Item #
FAN ASSEMBLIES, AND THERMOSTATS				HEATERS			
A.	4W Fan Assembly		(1)	E.	0395709	Modular Electric Defrost Heaters, 208V (HE.4850409)	(5)
	0392457	Fan Motor, Standard (MO.4410101)					
	0409511	Fan Blade, embossing toward motor (FB.0409511)		F.		Drip Pan Heaters, Electric 208V	(6)
B.	Optional Adjustable Refrigeration Thermostat, (2)				0392413	8 foot case (HE.0392413)	
					0392414	12 foot case (HE.0392414)	
C.	0398557	Defrost Termination Thermostat (Electric Defrost only) (CT.4440611)	(3)			Drip Pan Heaters, Koolgas 120V	(7)
					0421238	8 foot case (HE.4850496)	
					0421239	12 foot case (HE.4850497)	
D.	0425304	Heater Switch (Koolgas Defrost only) (CT.0425304)	(4)	G.		Nosing Anti-sweat Heaters	(8)
					0401605	8 foot case (Discharge) (HE.0401605)	
					0401557	8 foot case (Return) (HE.4850467)	
					0401606	12 foot case (Discharge) (HE.4850471)	
					0401558	12 foot case (Return) (HE.4850468)	

NOTE: Revision G corrects heater data on Page 4.

Engineering Plan Views

Low Temperature Single Deck Wall Models

Dimensions shown as inches & (mm).

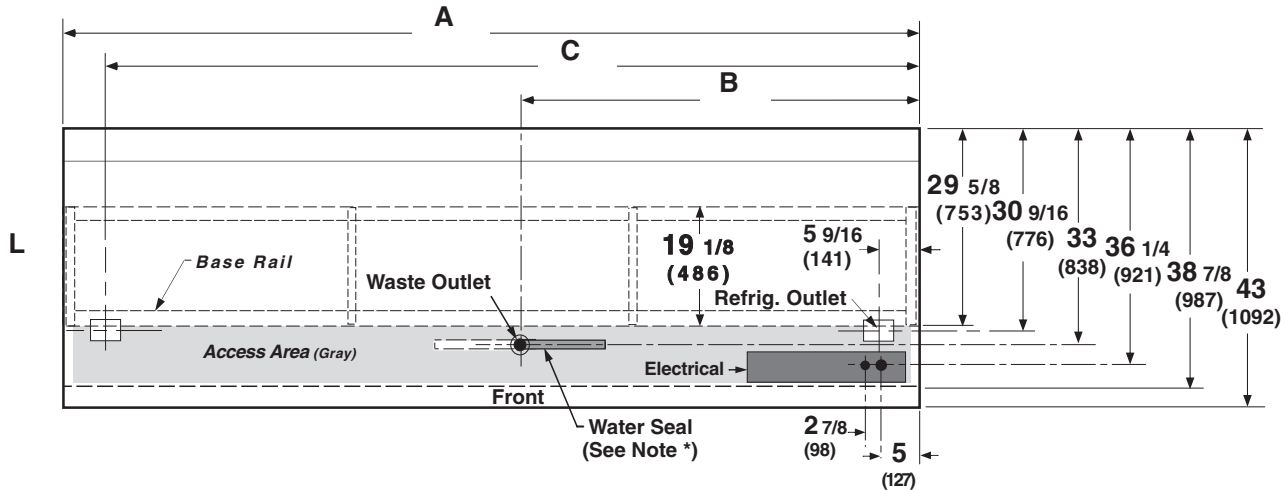

	8 ft	12 ft
General		
(A) Case Length <i>(without ends or partitions)</i> <i>(Each end and insulated partition adds 2 in. (51 mm) to case line up.)</i> Maximum O/S dimension of case back to front <i>(includes bumper)</i> Back of case to front of splashguard Back of case to O/S edge of front base rail Width of base rail Stub-up area (gray) between base rail and splashguard	96 1/4 (2445)	144 1/2 (3670)
Electrical Service <i>(Electrical Field Wiring connection point)</i> RH End of case to center of nearest knockout Back O/S of case to center of knockout	5 (127) 36 1/4 (921)	5 (127) 36 1/4 (921)
Waste Outlets (B) RH End of case to the center of waste outlet LH End of case to center of waste outlet Back O/S of case to center of waste outlet	58 1/4 (1480) 38 (965) 33 (838)	67 7/8 (1724) 76 5/8 (1946) 33 (838)
Water Seal Edge of water seal to center of waste outlet O/S diameter of drip pipe lines Note*: Field installed water seal outlet, tees and connectors are shipped with case.	11 (279) 1 1/2 (38)	11 (279) 1 1/2 (38)
Refrigeration Outlet (C) RH end of case to center of RH refrigeration outlet LH end of case to center of LH refrigeration outlet Back O/S of case to center of refrigeration outlet	5 9/16 (141) 88 3/8 (2245) 30 9/16 (776)	5 9/16 (141) 138 7/8 (3527) 30 9/16 (776)

Impact L

Frozen Food & Ice Cream

Dimensions shown in inches & (mm).

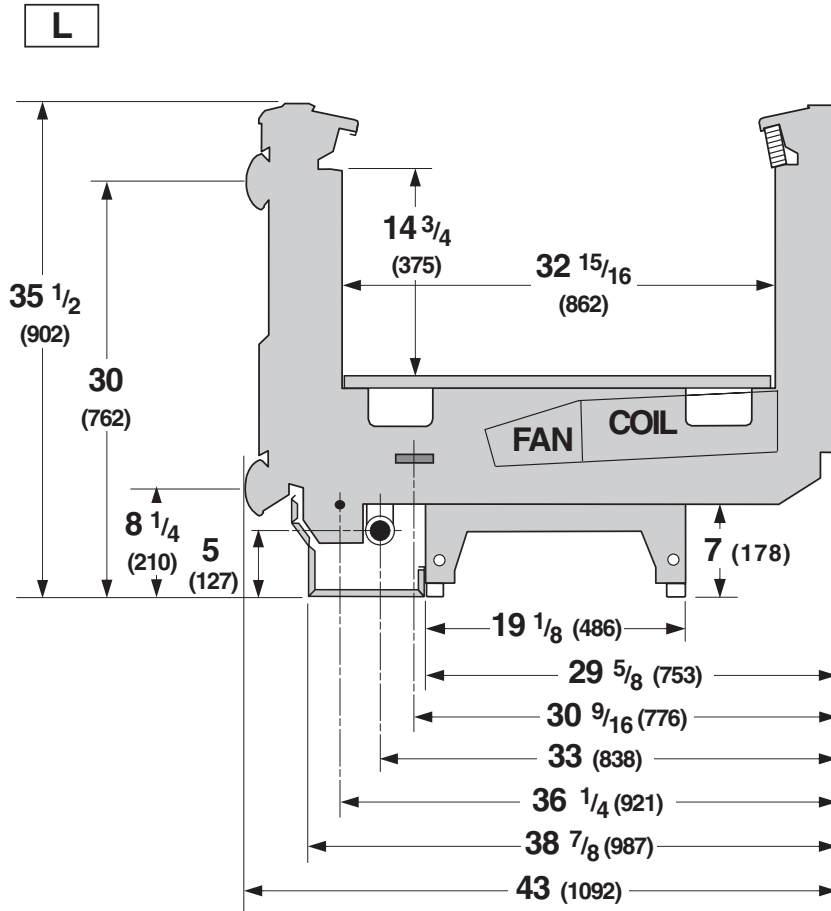

REFRIGERATION DATA

Note: This data is based on store temperature and humidity that does not exceed 75°F and 55% R.H.

	FF	IC
Discharge Air (°F)	-12	-22
Evaporator(°F)	-20	-30
Unit Sizing (°F)	-23	-33
Btu/hr/ft	FF	IC
Parallel	390	400
Conventional	405	415

DEFROST DATA

	FF	IC
Frequency (hr)	24	24
Defrost Water (lb/ft/day)	0.75	0.60

(± 15% based on case configuration and product loading).

ELECTRIC	FF	IC
Temp Term (°F)	48°	48°
Failsafe (minutes)	60	60

GAS	FF	IC
Duration (minutes)	15	18
OFFTIME	Not Recommended	

Standard Defrost Thermostat
Close on rise: close 48°F — open 33°F

CONVENTIONAL CONTROLS

Low Pressure Backup Control	FF	IC
CI/CO (Temp °F)*	-27°/-39°	-27°/-39°
Indoor Unit Only, Pressure Defrost Termination*	Not Recommended	

*Use a Temperature Pressure Chart to determine PSIG conversions.

PHYSICAL DATA

Drip Pipe (in.)	1 1/4
Liquid Line (in.)	3/8
Suction Line (in.)	5/8

Estimated Charge (lb)**

8 ft	1.7
12 ft	2.6

**This is an average for all refrigerant types. Actual refrigerant charge may vary by approximately half a pound.

Length Added to Lineup by Each End/Partition (in.)	1 1/2
---	-------

NSF Certification

These merchandisers are manufactured to meet ANSI /National Sanitation Foundation (NSF®) Standard #7 requirements.

Impact L Frozen Food & Ice Cream

Electrical Data

	8 ft	12 ft
Number of Fans – 4W	2	3
(Energy Efficient fan motors are not available for End or End-compartment models)		

			Amperes		Watts	
			8 ft	12 ft	8 ft	12 ft
Evaporator Fans						
120V	60Hz	Standard	0.62	0.93	48	72
120V	50Hz	Standard	NA			
230V	60Hz	Export	0.30	0.45	48	72
230V	50Hz	Export	0.36	0.54	54	81
120V	60Hz	Energy Efficient	0.28	0.42	20	30
230V	60Hz	Energy Efficient	NA			

Nosing Anti-sweat Heaters (on fan circuit)						
120V	60Hz	Standard	0.94	1.40	112	168
230V	50Hz	Export	0.49	0.73	112	168

Cycling Anti-sweat Heaters			NA			
230V	50hz	Export	NA			

Minimum Circuit Ampacity						
120V	60Hz	Standard	1.76	2.53		
120V	50Hz	Standard	NA			
230V	60Hz	Export	0.99	1.38		
230V	50Hz	Export	1.05	1.47		
120V	60Hz	Energy Efficient	1.42	2.02		
230V	60Hz	Energy Efficient	NA			

Maximum Over Current Protection 120V			20	20		
Maximum Over Current Protection 230V			15	15		

Electric Defrost Heaters						
<u>208V</u>	60Hz	Standard	8.0	12.0	1670	2505
230V	50Hz	Export	8.9	13.3	2040	3060

Koolgas Drip Pan Heaters						
120V	60Hz	Standard	2.50	3.75	300	450
<u>230V</u>	50Hz	Export	NA			

Standard Lighting: None

Electric Defrost – Standard

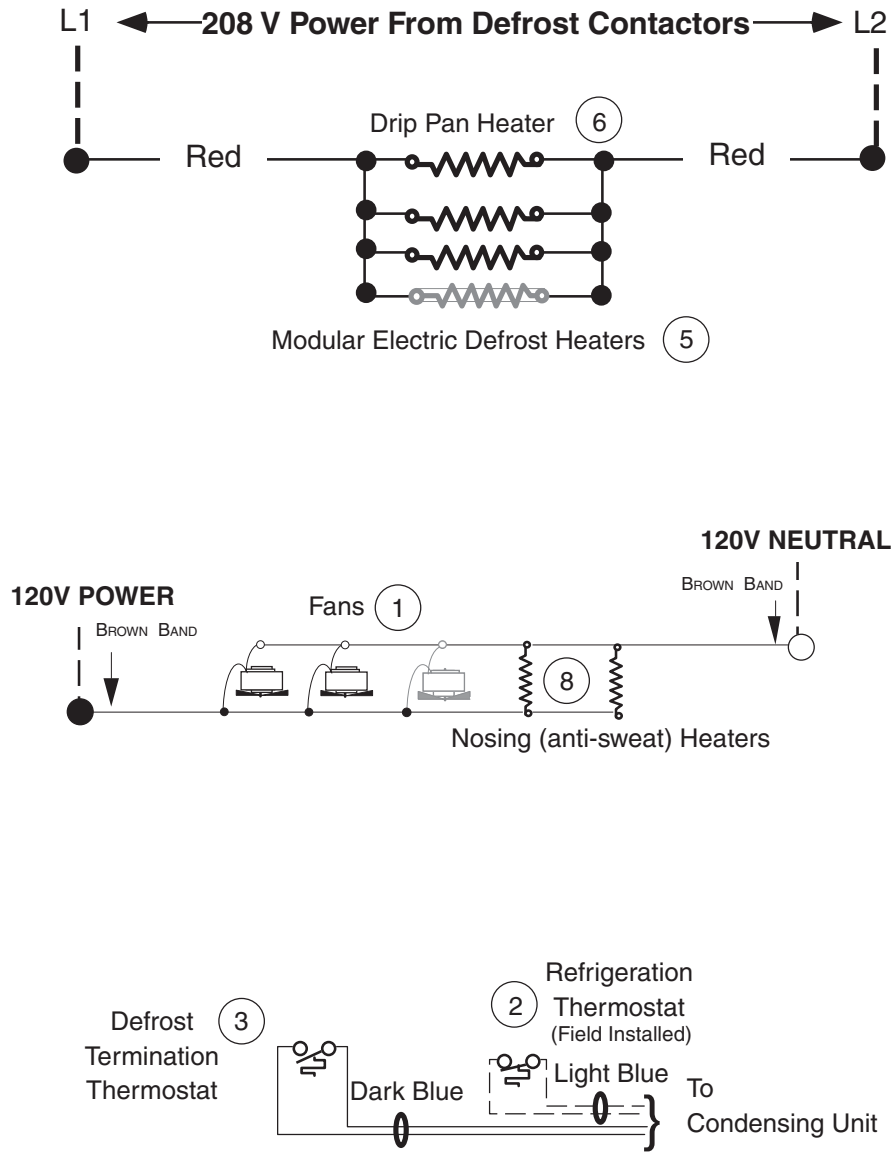

WARNING

All components must have mechanical ground, and the merchandiser must be grounded.
 Circled Numbers = Parts List Item Numbers
 Grayed components in 12 foot models only.

Gas Defrost – Optional

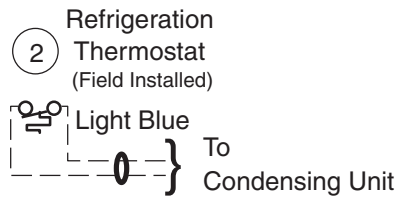
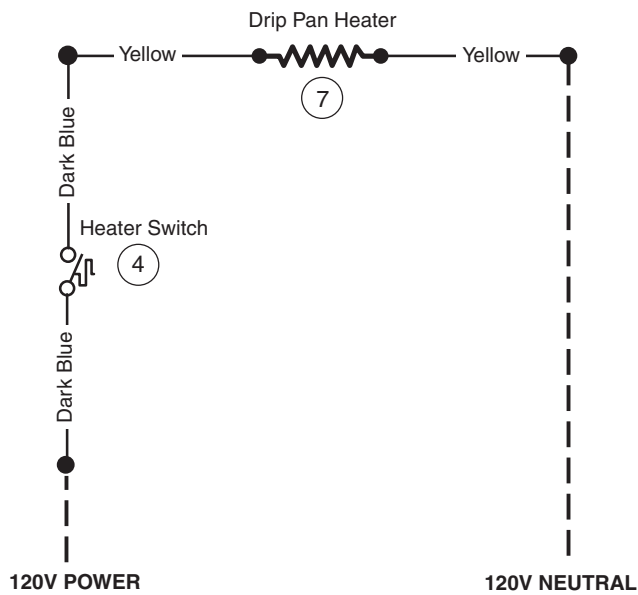
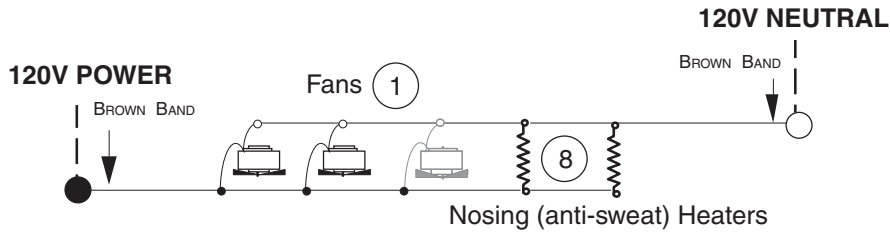

WARNING

All components must have mechanical ground, and the merchandiser must be grounded.
 Circled Numbers = Parts List Item Numbers
 Grayed components in 12 foot models only.