

We reserve the right to change or revise specifications and product design in connection with any feature of our products. Such changes do not entitle the buyer to corresponding changes, improvements, additions or replacements for equipment previously sold or shipped.

Item	Part #	Description	Wiring Item #	Item	Part #	Description	Wiring Item #
FAN ASSEMBLIES AND THERMOSTATS				HEATERS			
A.	7W Standard	Fan Assembly	(1)	D.	Canopy Anti-Sweat Heater		(4)
	0058698	Fan Motor, Evaporator (MO.4410102)			0572499	4 ft (HE.)	
	0142780	Fan Blade (FB.0142780) embossing toward motor			0512500	6 ft (HE.)	
					0512501	8 ft (HE.)	
					0512502	12 ft (HE.)	
A.	7W Energy Efficient	Fan Assembly	(1)	LAMPS AND BALLASTS			
	0477654	Fan Motor, Evaporator (MO.4410545)		E.	Ballast, Electronic		(5)
	0142780	Fan Blade (FB.0142780) embossing toward motor			0466233	1 lamps (BA.4481300)	
					0466234	2 lamps (BA.4480823)	
					0466235	3 lamps (BA.4480901)	
B.	0411744	Standard Non-adjustable Defrost Thermostat (CT.0411744)	(2)	F.	Fluorescent Lamp		(6)
					<i>Replace with like fixtures</i>		
C.		Optional Adj Refrigeration Thermostat	(3)				

Note: adds aftermarket part numbers, Btu note on page 3, new page 5; updates electrical data on page 4.



Engineering Plan Views

PHYSICAL DATA

Merchandiser Drip Pipe (in.)	1 1/2
Merchandiser Liquid Line (in.)	3/8
Merchandiser Suction Line (in.)	7/8





Dairy / Delicatessen Precut & Packaged Produce

05-2003

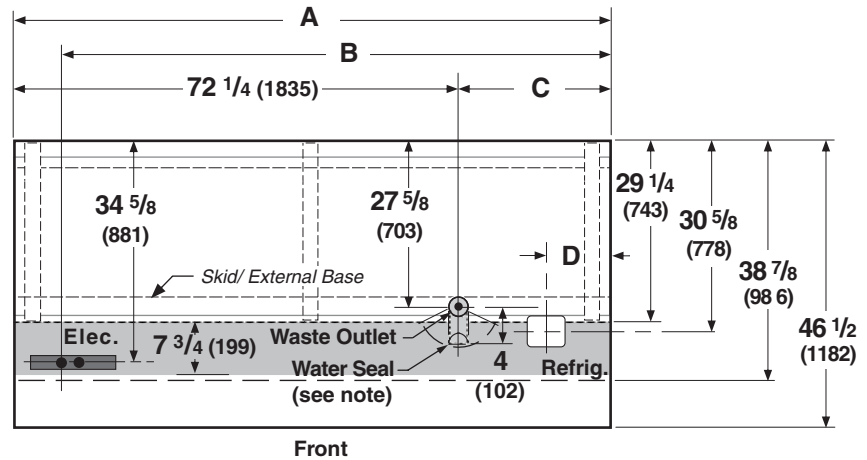
C2LGE

Dimensions shown as inches and (mm).



	4 ft	6 ft	8 ft	12 ft
General				
(A) Case Length (without ends or partitions) <i>(Each end and insulated partition adds 1 1/2 in. (38 mm) to case line up.)</i>	48 1/4 (1226)	72 3/8 (1838)	96 3/8 (2448)	144 1/2 (3670)
Maximum O/S dimension of case				
back to front (includes bumper)	46 1/2 (1182)	46 1/2 (1182)	46 1/2 (1182)	46 1/2 (1182)
Back of case to front of splashguard	38 7/8 (986)	38 7/8 (986)	38 7/8 (986)	38 7/8 (986)
Back of case to O/S edge of front skid rail	29 1/4 (743)	29 1/4 (743)	29 1/4 (743)	29 1/4 (743)
Width of skid rail	4 1/2 (114)	4 1/2 (114)	4 1/2 (114)	4 1/2 (114)
RH end of case to outside edge of external support	5 1/2 (140)	5 1/2 (140)	5 1/2 (140)	5 1/2 (140)
Distance between edges of external and center supports	NA	31 1/8 (790)	40 5/8 (1032)	40 5/8 (1032)
Distance between edges of center supports	41 1/4 (1048)	NA	NA	44 (1118)
Stub-up area between front skid rail and splashguard	7 3/4 (199)	7 3/4 (199)	7 3/4 (199)	7 3/4 (199)
Electrical Service  <i>(Electrical Field Wiring connection point)</i>				
(B) RH End of case to center of farthest knockout	38 1/4 (972)	64 3/8 (1635)	88 3/8 (2245)	136 1/2 (3467)
Back O/S of case to center of knockout	34 5/8 (881)	34 5/8 (881)	34 5/8 (881)	34 5/8 (881)
Length of electrical raceway	16 1/8 (410)	34 1/2 (876)	35 5/8 (903)	35 5/8 (903)
Waste Outlet 				
(C) RH End of case to the center of waste outlet	24 1/8 (613)	24 1/8 (613)	24 1/8 (613)	72 1/4 (1835)
LH End of case to the center of waste outlet	24 1/8 (613)	48 1/4 (1226)	72 1/4 (1835)	72 1/4 (1835)
Water Seal 				
Edge of water seal to center of waste outlet	4 (102)	4 (102)	4 (102)	4 (102)
Outside diameter of the drip pipe	1 1/2 (38)	1 1/2 (38)	1 1/2 (38)	1 1/2 (38)
<i>Note: Water seal outlet must clear front skid rail.</i>				
Refrigeration Outlet 				
Back of case to center of refrigeration outlet	30 5/8 (778)	30 5/8 (778)	30 5/8 (778)	30 5/8 (778)
(D) RH end of case to center of refrigeration outlet	9 (230)	9 (230)	9 (230)	9 (230)

Impact C2-LGE
Dairy / Delicatessen
Precut & Packaged Produce

REFRIGERATION DATA

Note: This data is based on store temperature and humidity that does not exceed 75°F and 55% R.H.

	C2-LGE
Discharge Air (°F)	27
Evaporator (°F)	21
Unit Sizing (°F)	19

<i>Btu/hr/ft*</i>	C2-LGE
Parallel	955
Conventional	1050

*Optional energy efficient motors reduce the refrigeration load by 18 Btu/hr/ft.

DEFROST DATA

	C2-LGE
Frequency (hr)	6
Defrost Water (lb/ft/day) (± 15% based on case configuration and product loading).	6
OFFTIME	C2-LGE
Temp Term (°F)	48°F
Failsafe (minutes)	30

ELECTRIC OR GAS Not Recommended

Standard Defrost Thermostat

Close on rise: close 48°F — open 33°F

CONVENTIONAL CONTROLS

Low Pressure Backup Control

	C2-LGE
CI/CO**	17°F / 7°F

Indoor Unit Only, Pressure Defrost

Termination** 48°F

**Use a Temperature Pressure Chart to determine PSIG conversions.

Estimated Charge (lb)***

4 ft	1.3
6 ft	1.8
8 ft	2.3
12 ft	3.3

***This is an average for all refrigerant types. Actual refrigerant charge may vary by approximately half a pound.

Dimensions shown as inches and (mm).

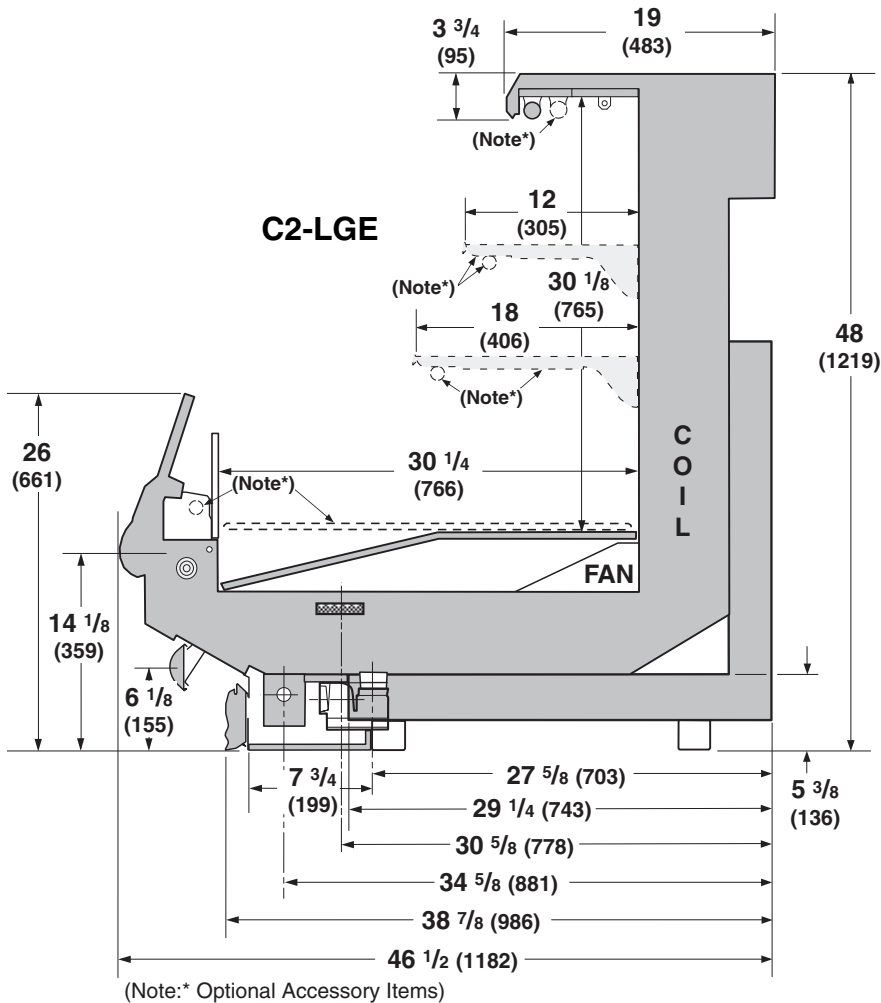

NSF Certification

This merchandiser model is manufactured to meet ANSI/NSF (National Sanitation Foundation) Standard #7 requirements for construction, materials & cleanability.

Impact C2-LGE Dairy / Delicatessen Precut & Packaged Produce

Electrical Data

	4 ft	6 ft	8 ft	12 ft				
Number of Fans	1	2	2	3				
	Amperes				Watts			
	4 ft	6 ft	8 ft	12 ft	4 ft	6 ft	8 ft	12 ft
Evaporator Fan								
120V 60Hz Standard	<u>0.50</u>	<u>1.00</u>	<u>1.00</u>	<u>1.50</u>	39	78	78	117
120V 50Hz Standard	0.55	1.10	1.10	1.65	42	84	84	126
230V 60Hz Export	0.25	0.50	0.50	0.75	40	80	80	120
230V 50Hz Export	0.28	0.56	0.56	0.84	44	88	88	132
120V 60Hz Energy Efficient	0.19	0.38	0.38	0.57	14	28	28	42
230V 60Hz Energy Efficient	NA							
Canopy Anti-sweat Heaters	<u>0.15</u>	<u>0.20</u>	<u>0.25</u>	<u>0.30</u>	<u>18</u>	<u>24</u>	<u>30</u>	<u>36</u>
Minimum Circuit Ampacity								
120V 60Hz Standard	<u>0.85</u>	<u>1.40</u>	<u>1.45</u>	<u>2.00</u>				
120V 50Hz Standard	<u>0.90</u>	<u>1.50</u>	<u>1.55</u>	<u>2.15</u>				
230V 60Hz Export	<u>0.60</u>	<u>0.90</u>	<u>0.95</u>	<u>1.25</u>				
230V 50Hz Export	<u>0.63</u>	<u>0.96</u>	<u>1.01</u>	<u>1.34</u>				
120V 60Hz Energy Efficient	<u>0.54</u>	<u>0.78</u>	<u>0.83</u>	<u>1.07</u>				
230V 60Hz Energy Efficient	NA							
Maximum Over Current Protection 120V	20	20	20	20				
Maximum Over Current Protection 230V	15	15	15	15				
Standard Lighting								
1 Row Canopy	0.26	0.51	0.51	0.77	30	59	59	85
Optional Lighting								
Additional 1 Row Canopy	0.26	<u>0.50</u>	<u>0.50</u>	<u>0.75</u>	<u>31</u>	<u>60</u>	<u>60</u>	<u>90</u>
Additional 2 Row Canopy	<u>0.50</u>	<u>1.00</u>	<u>1.00</u>	<u>1.50</u>	<u>60</u>	<u>120</u>	<u>120</u>	<u>180</u>
1 Row Rail Light	0.26	<u>0.50</u>	<u>0.50</u>	<u>0.75</u>	<u>31</u>	<u>60</u>	<u>60</u>	<u>90</u>
1 Row Ledge Light	0.26	<u>0.50</u>	<u>0.50</u>	<u>0.75</u>	<u>31</u>	<u>60</u>	<u>60</u>	<u>90</u>
Optional Shelf Lighting								
1 Row Shelf Receptacle	0.26	<u>0.50</u>	<u>0.50</u>	<u>0.75</u>	<u>31</u>	<u>60</u>	<u>60</u>	<u>90</u>
2 Row Shelf Receptacle	<u>0.50</u>	<u>1.00</u>	<u>1.00</u>	<u>1.50</u>	<u>60</u>	<u>120</u>	<u>120</u>	<u>180</u>

115V Lighting Circuit Total = Standard Lighting + Total Optional Lighting + Optional Shelf Lighting

230V Lighting Circuit Total = Mutiply 115V Lighting Circuit Total by 0.52

Product Data

<i>Recommended Usable Cube</i> ² (Cu Ft/Ft)	3.08 ft ³ /ft (0.29 m ³ /m)
<i>ARI Total Display Area</i> ³ (Sq Ft/Ft)	3.11 ft ² /ft (0.95 m ² /m)
<i>Shelf Area</i> ³ (Sq Ft/Ft)	5.04 ft ² /ft (1.54 m ² /m)

- ¹ ARI Refrigerated Volume less shelving and other unusable space: Refrigerated Volume/Unit of Length, ft³/ft [m³/m]
- ² Computed using ARI 1200 standard methodology: Total Display Area, ft² [m²]/Unit of Length, ft [m]
- ³ Shelf surface area is composed of bottom deck plus standard shelf complement, as shown in the Hussmann *Product Reference Guide*. The standard shelf complement for this model is (2) rows of 22-inch shelves.

ESTIMATED SHIPPING WEIGHT ⁵					
Case	<i>4 ft</i>	<i>6 ft</i>	<i>8 ft</i>	<i>12 ft</i>	Solid End
					<i>(each)</i>
lb (kg)	550 (249)	700 (318)	850 (386)	1100 (499)	100 (45)

⁵ Actual weights will vary according to optional kits included.

1, 2 & 3 Fans

- 4 ft — 1 Fan
- 6 ft — 2 Fans
- 8 ft — 2 Fans
- 12 ft — 3 Fans

Fan Wiring Offtime Defrost

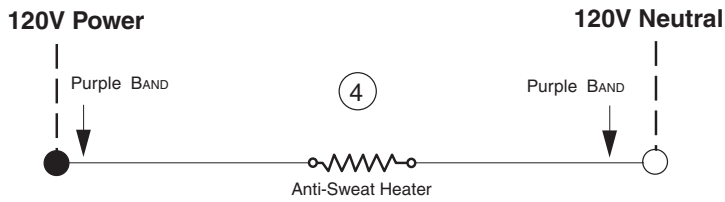
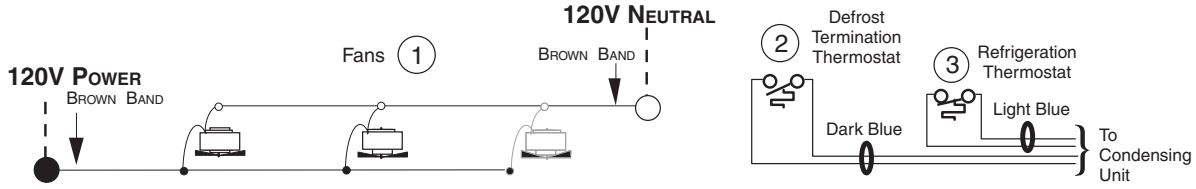

Canopy Anti-Sweat Heater

Optional Shelf Harness and Light Circuits for One Row of Shelves

Shelf Lighting

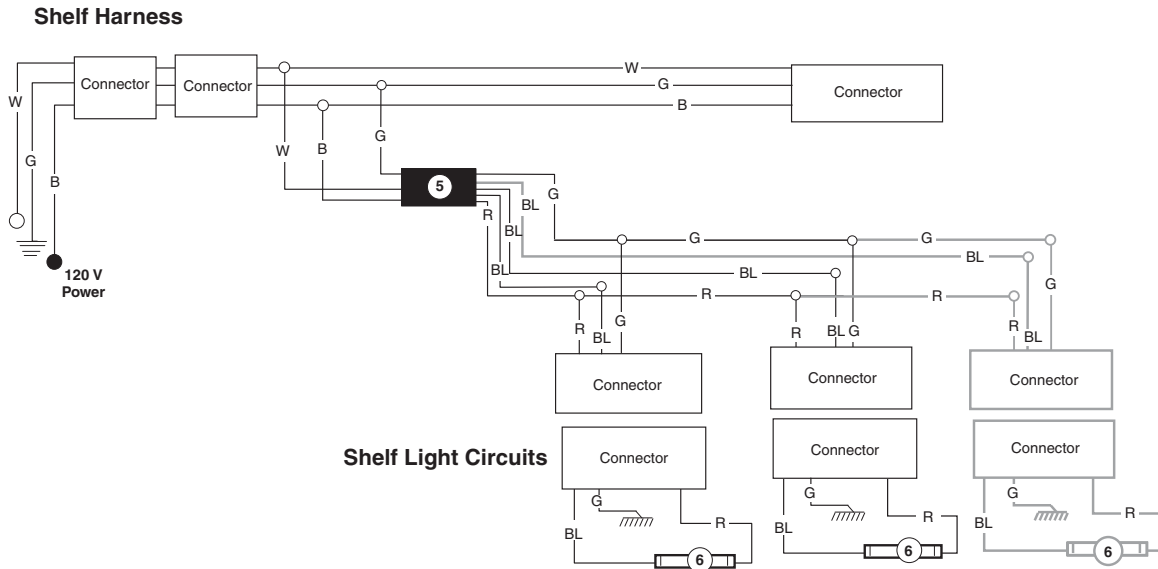

WARNING

All components must have mechanical ground, and the merchandiser must be grounded.

CIRCLED NUMBERS = PARTS LIST ITEM NUMBERS

Grayed components in 12 foot models only.

R = Red Y = Yellow G = Green BL = Blue B = Black W = White

● = 120V POWER ○ = 120V NEUTRAL ≡ = Field GROUND ≡≡ = Case GROUND

Light Circuits

Standard Lighting 1 Row Canopy or Optional 1 Row Rail

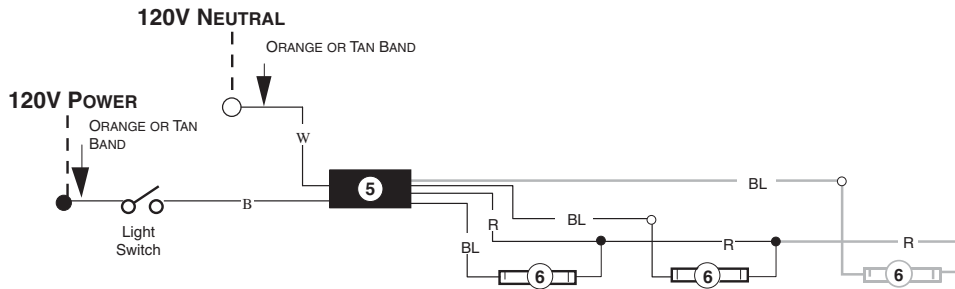

Optional Lighting 2 Rows Canopy

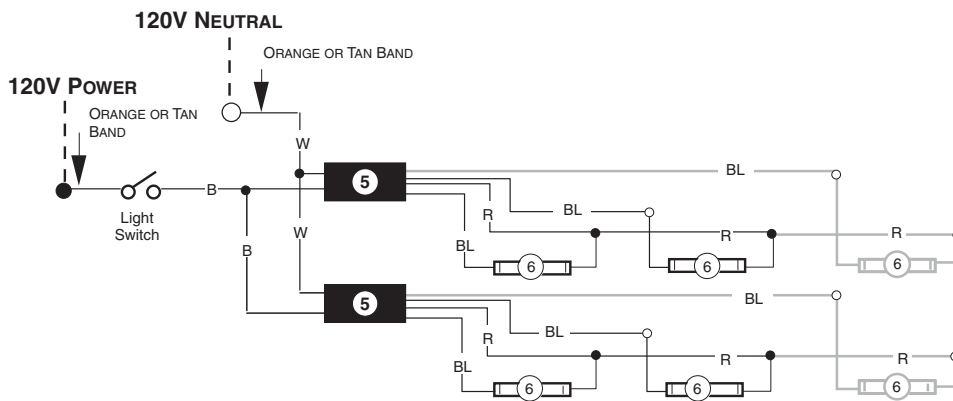

WARNING

All components must have mechanical ground, and the merchandiser must be grounded.

CIRCLED NUMBERS = PARTS LIST ITEM NUMBERS

Grayed components in 12 foot models only.

R = Red Y = Yellow G = Green BL = Blue B = Black W = White

● = 120V POWER ○ = 120V NEUTRAL

Impact C2-LGE
Dairy / Delicatessen
Precut & Packaged Produce

SHELF CONFIGURATION

This merchandiser is designed for one or two shelves.

The depth of the shelf used in the top eight (8) shelf hole locations is critical to case performance.

If a shelf is placed in one of the top eight (8) locations it must comply with the angle/depth requirements listed below.

Shelf Angle	Maximum Shelf Depth
0°	12 in.
15°	14 in. or less
30°	18 in. or less
45°	18 in. or less

NOTE: Shelves placed in the lower positions may be up to 18 in. deep when positioned at a 0° angle.

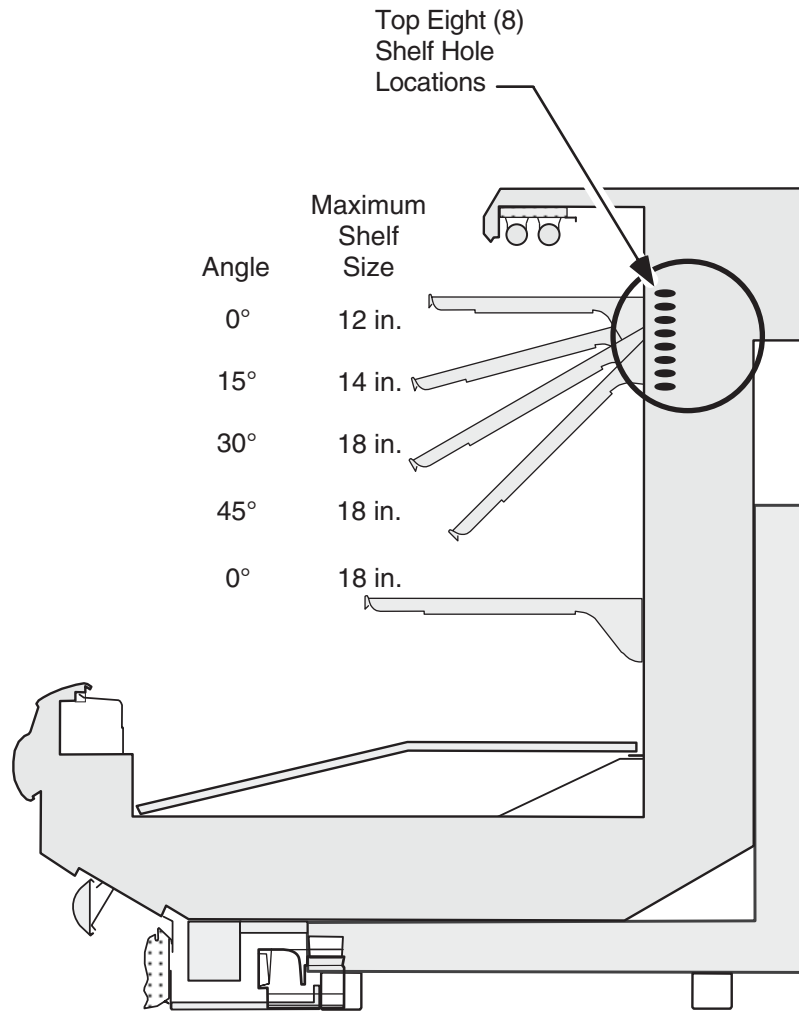

Impact C2-LGE
Dairy / Delicatessen
Precut & Packaged Produce

CANOPY AND SHELF LAMP BALLAST

The ballast for the canopy and shelf lamps is located behind the canopy on the left-hand end (when facing case) of the merchandiser.

To access the ballast:

1. Remove screws at bottom edge of canopy and rear of top panel.
2. Remove the one piece canopy top panel by moving panel forward slightly to clear flange in front then lifting up.
3. Service or replace ballasts as required.
4. Reassemble items as they were originally installed.

NOTE: Rail lamp ballast is located behind the lower front panel.

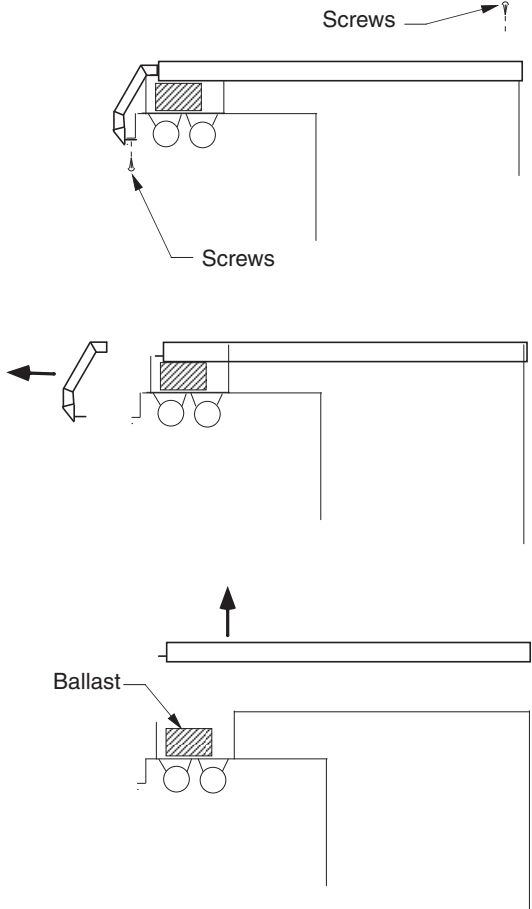

CANOPY ANTI-SWEAT HEATER

The canopy anti-sweat heater location is shown below. Connections are in the Electrical wireway.

