

# HUSSMANN® IMPACT

Wide Island End Cap (6') to Wide Island Merchandiser

Joint Kit Instruction  
LWE TO LW OR LWU

LWEG TO LWG OR LWUG

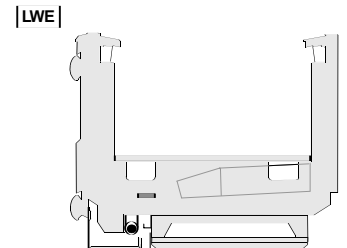
## For Low Temperature Island Merchandisers

### PARTS LIST

Item No.	Quantity		Description
	LWE	LWEG	
1.	8	4	Joining Strap
2.	20	12	Hex Head Sheet Metal Screws 8 x 1/2
3.	2	2	Styrofoam Insulation
4.	1	1	Silicone
5.	1	1	Gasket 1/2 x 1/2 x 180
6.	1	1	Gasket 1 5/8 x 1/2 x 180
7.	1	1	Neoprene Gasket
8.	1	1	Center Flue Joining Bracket (2 Pieces)
9.	2	2	Hex Nut 3/8 x 24
10.	4	2	Cap Screw 5/16-18 x 1
11.	4	2	Lock Washer Split Steel; 5/16
12.	4	2	Flat Washer 5/16
13.	4	2	Hex Nut 5/16 - 18
14.	-	2	Cover — Glass Post End
15.	12	10	Screw Phillips Sheet Metal 8 x 1/2
16.	2	2	Nosing Joint Trim
17.	1	1	Nosing Joint Trim Center
18.	2	-	Nosing Joint Side Trim

**Splashguard Brackets  
MUST BE INSTALLED  
Before Piping Case.**

**NOTE:**  
Refer to the Installation  
Manual to install  
splashguard brackets.



KIT

INT

0

2

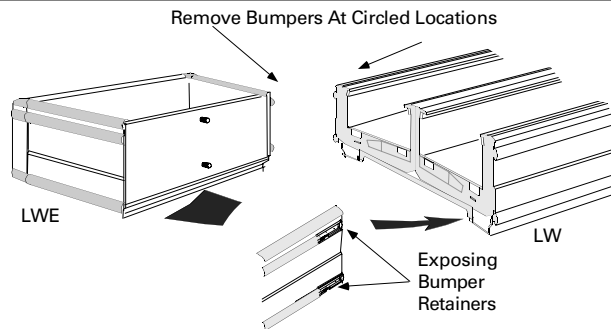
**NOTE:** Be sure merchandisers have been leveled according to the installation instructions. Carefully unpack and inspect the Wall/Island Joint Kit, making sure there is no breakage or damage.

### STEPS

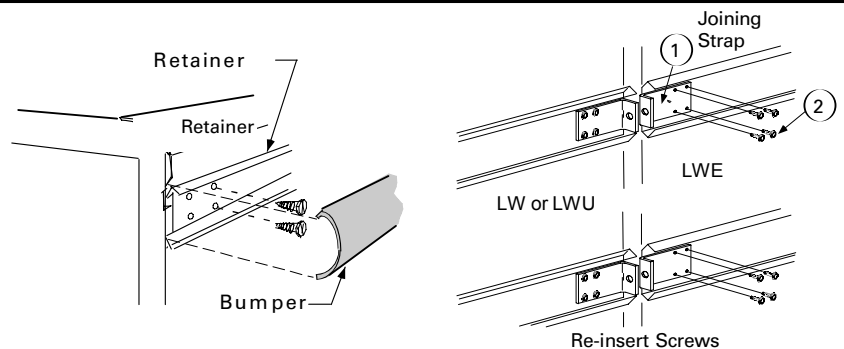
**1** Remove the **Bumper** so as to expose the bumper retainer.

**2** Remove two (2) existing screws holding bumper retainer to the vertical brace. **Save the screws for re-insertion later.**

**3** Attach the **Joining Strap - 1** to the bumper retainer using screws from Step 2 and **Screws - 2** provided.

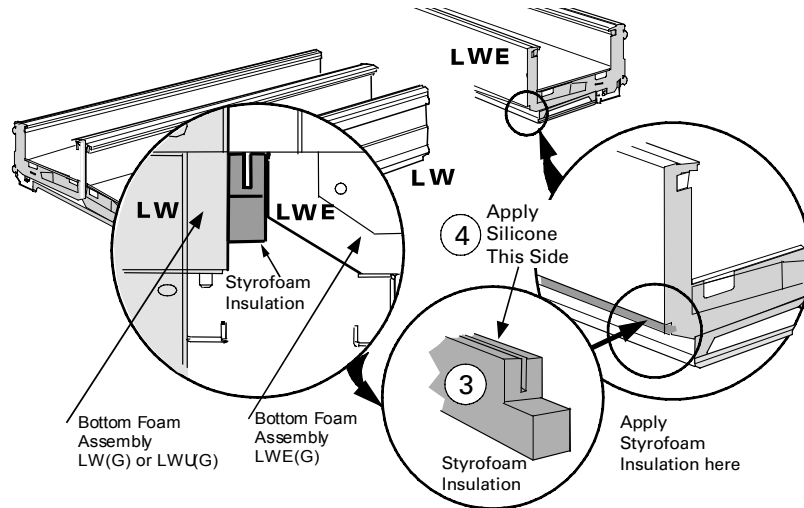


**Figure 1.** Removing the Bumpers



**Figures 2 and 3.** Removing Bumpers, Existing Screws, and Installing Joining Strap

**4** Install the **Styrofoam Insulation – 3**, by applying **Silicone – 4** to one side of styrofoam. Place the styrofoam filler into the corner created by flat foam assembly and bottom. Push until the silicone makes contact with the case causing the styrofoam to stay in place.

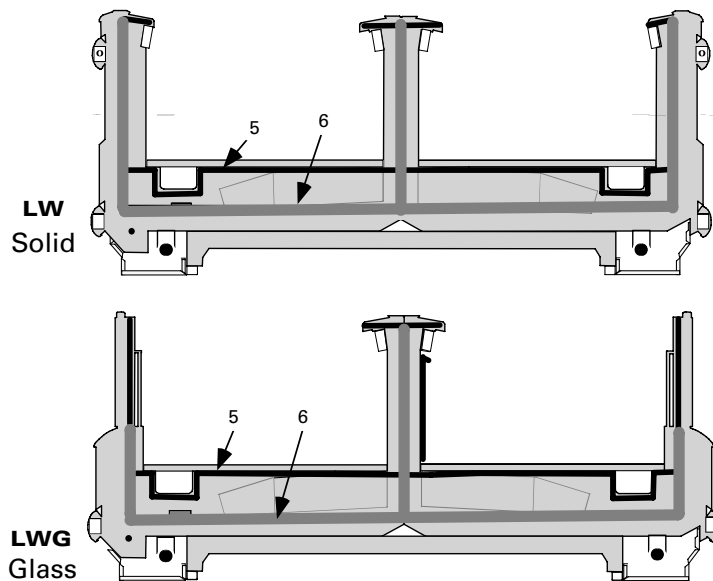
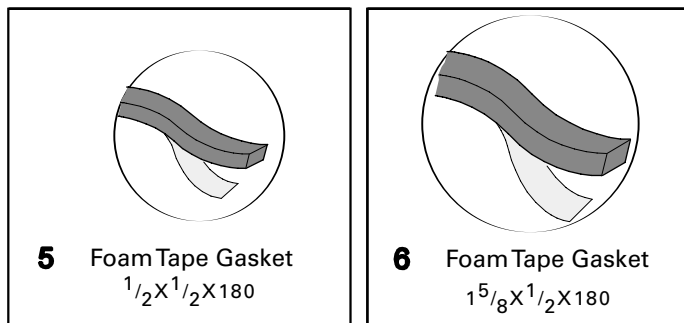


**Figure 4.** Installing Styrofoam Insulation

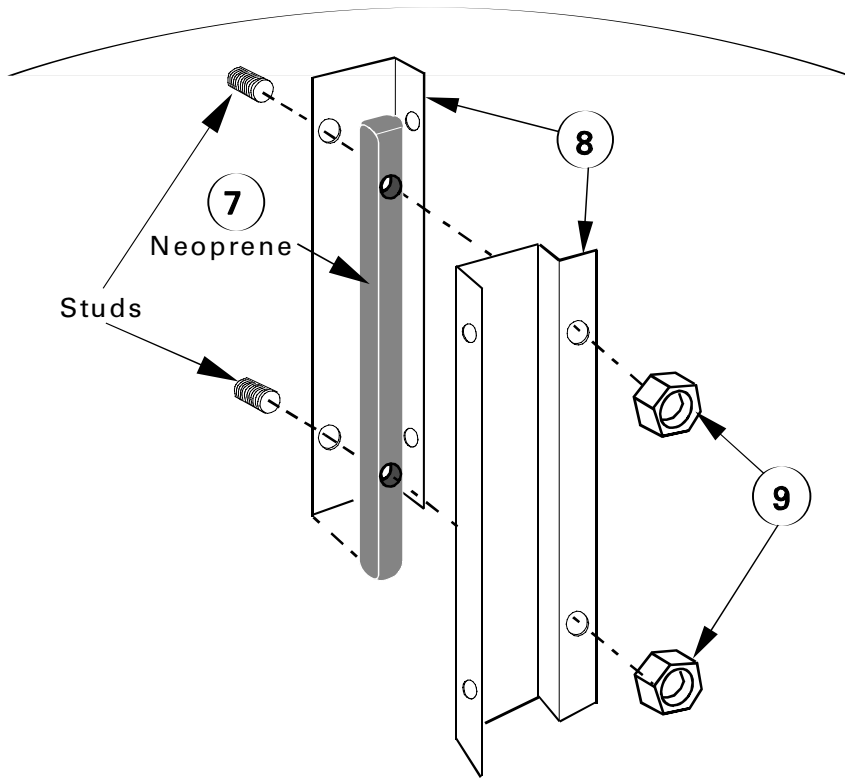
**NOTE: APPLY GASKET TO ONE CASE ONLY.**

**5** Apply **Gaskets – 5 and 6** as shown in Figure 5.

- Remove paper backing as gasket is applied.
- Lap gaskets at lower corners.
- Check that there are no gaps between gasket and the merchandiser.
- Do not stretch gasket, especially around corners.
- Do not butt gaskets; always overlap joints.

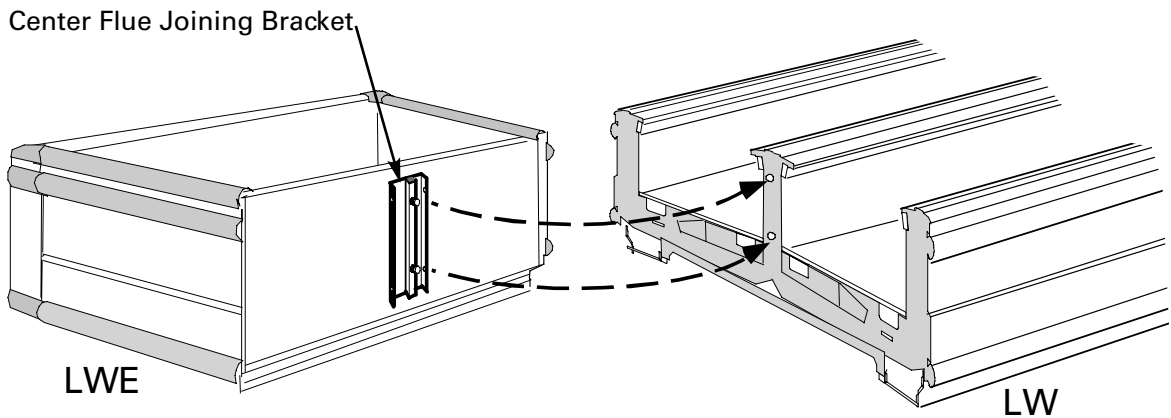


**Figure 5.** Installing Gasket Solid and Glass



Detail A.

- 6** **A.** Place one half of the **Center Flue Joining Bracket - 8** over stud on the back of the LWE case.
- B.** Apply strip of **Neoprene - 7** over the stud and onto the bracket half that was just installed.
- C.** Place the other half of the **Center Flue Joining Bracket - 8** over the stud and onto the Neoprene.
- D.** Fasten the Joining brackets and Neoprene together using **Hex Nut - 9**, see Detail A.
- 7** Move Wide Island End Cap (LWE) against Wide Island (LW), see Figure 6.



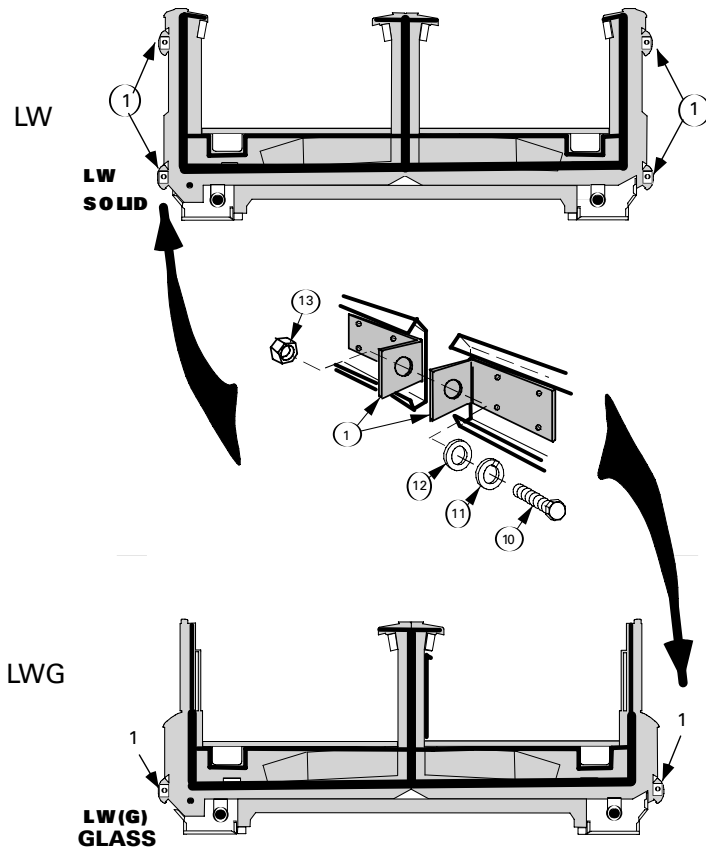
**Figure 6.** Moving the Cases Together

**8** Begin Fastening the cases together at the **Joining Straps - 1**, starting at the bottom first.

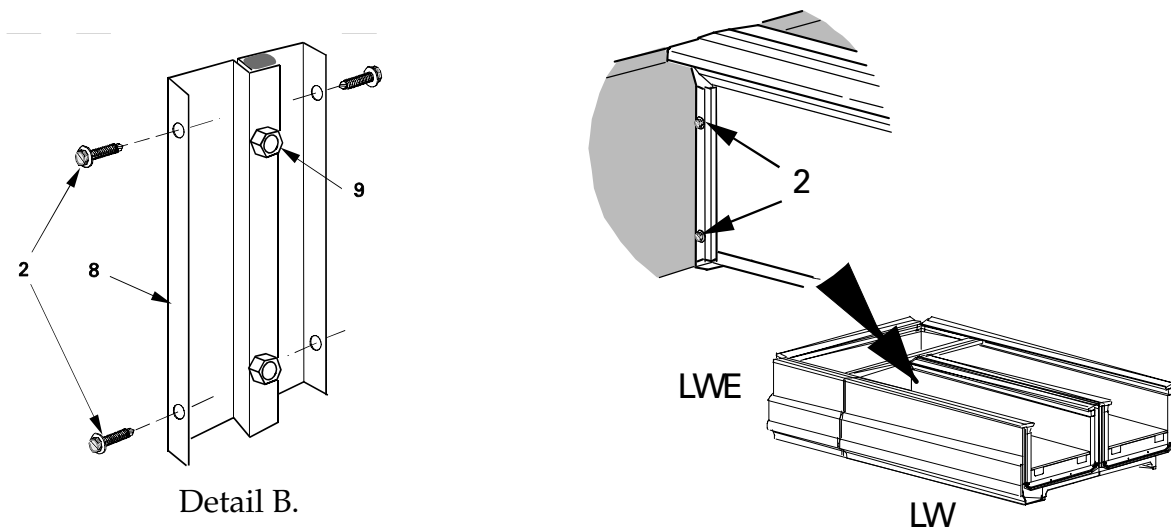
**9** Fasten the joining straps together using, **Cap Screw - 10**, **Lock Washer - 11**, **Flat Washer - 12** and **Hex Nut - 13**.

**10** Fasten the Joining Bracket to the side of the Wide Island Center Flue using **Screws - 2** (see Figure 8, Detail B).

**NOTE:** Refer to the *Installation Instruction* to install the splash-guard brackets.



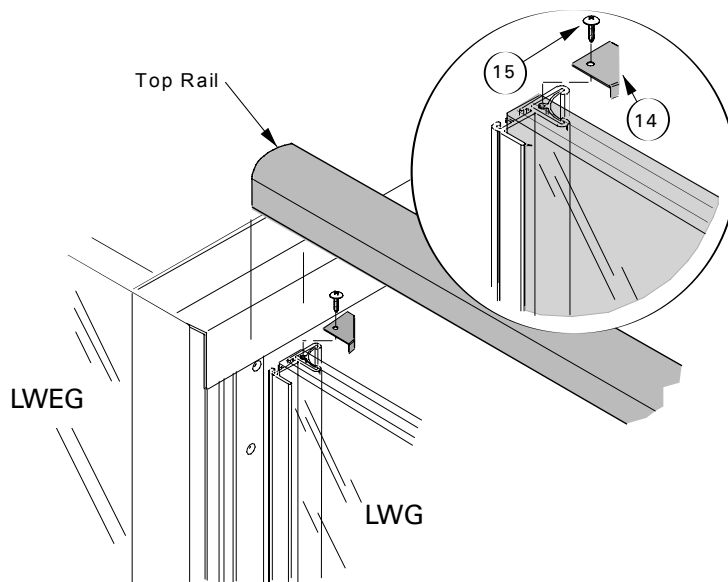
**Figure 7.** Installing and Fastening Joining Straps to Cases



**Figure 8.** Fastening the Cases at the Center Flue

**LWE TO LW OR LWU  
LWEG TO LWG OR LWUG JOINT KIT**

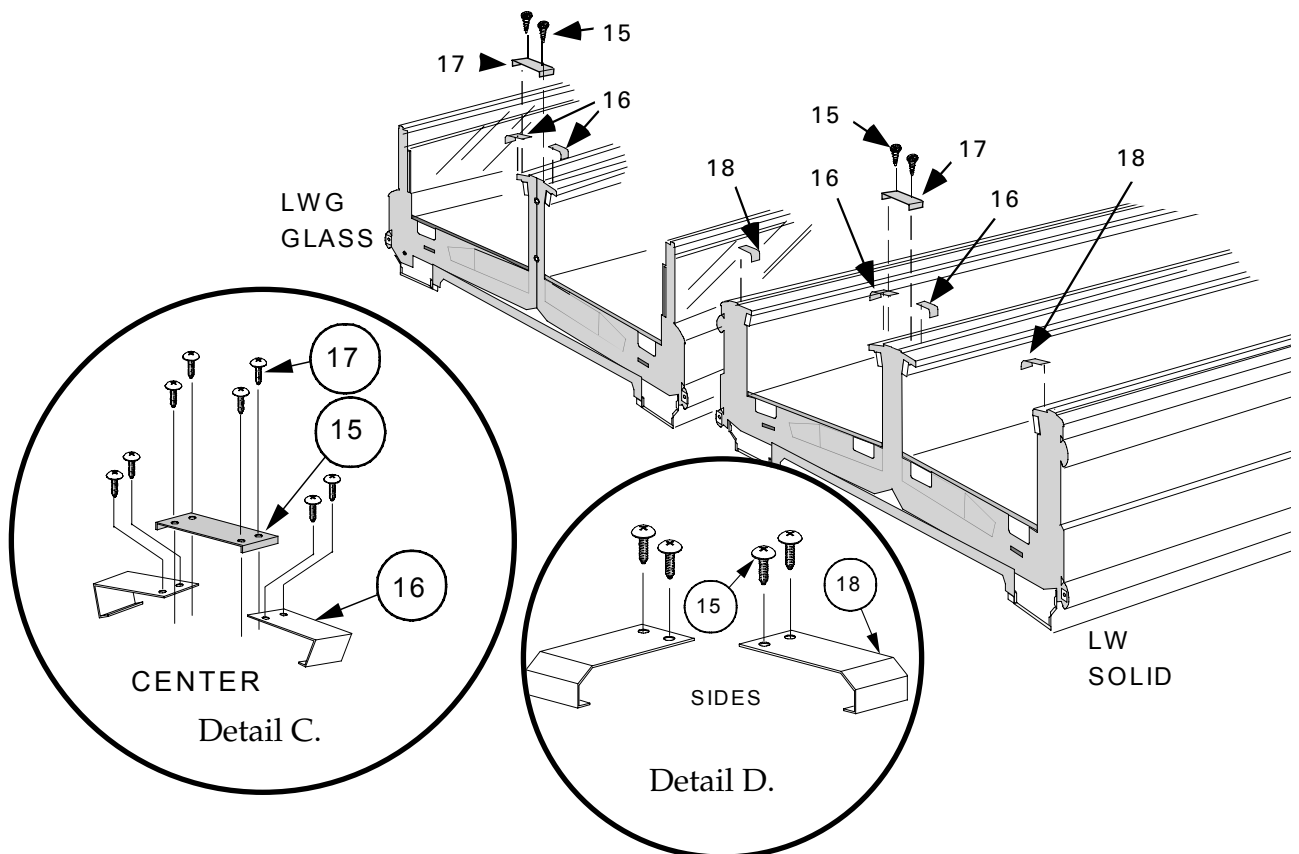
**P/N 0398652A**



**IF INSTALLING GLASS  
CASES**

- 11** Install the **Glass Post End Cover - 14**, using **Screws - 15**.
- 12** Install **Plastic Top Rails**. **Make sure to offset joints from case joints** (see Figure 9).
- 13** Use **Screws - 15** to attach **Trims - 16, 17 and 18**, at the locations shown in Figure 10, Details C and D.

**Figure 9.** Installing Glass Cover-Post End and Top Rails



**Figure 10.** Installing Trims