

Refrigeration and electrical connections are on top. Overhead piping and electrical circuits are required.

We reserve the right to change or revise specifications and product design in connection with any feature of our products. Such changes do not entitle the buyer to corresponding changes, improvements, additions or replacements for equipment previously sold or shipped.

220V Parts List is on Page 8.

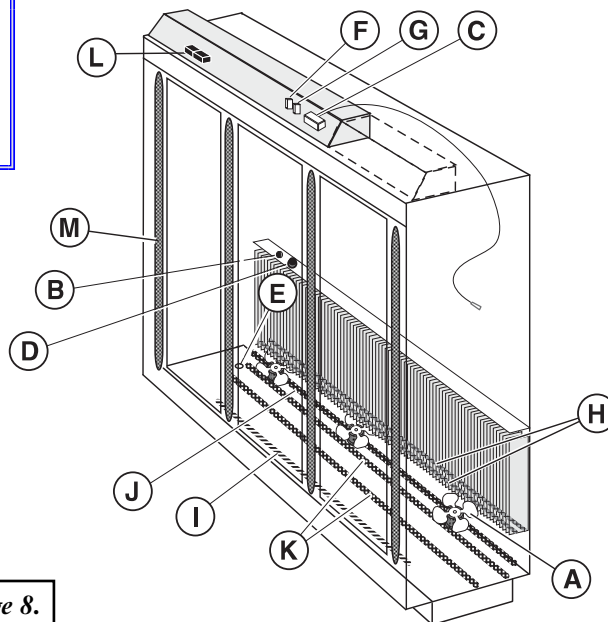

**Warning:**  
 Terminal block NOT for case-to-case wire connection!

Item	Part #	Description	Wiring Item #	Item	Part #	(Qty)	Description	Wiring Item #
<b>FAN ASSEMBLIES, AND THERMOSTATS</b>				<b>HEATERS (CONTINUED)</b>				
(A)	Fan Assembly		(1)	(J)	Koolgas Supplemental Heater – Plenum	(10)		
	0477658	Standard Energy Efficient Motor (MO.4410549)			(120V)			
	0315470	Fan Blade (FB.0315470)		0452980	(1)	2 Door Models (HE.4850576)		
(B)	0331798	Standard Non-adjustable Defrost Thermostat (CT.4440256)	(2)	0452981	(1)	3 Door Models (HE.4850577)		
(C)		Optional Adjustable Refrigeration Thermostat	(3)	0452982	(1)	4 Door Models (HE.4850510)		
(D)	0440423	Defrost Limit Thermostat (CT.4481089)	(4)	0452983	(1)	5 Door Models (HE.4850578)		
(E)	0446007	Relay Control Thermostat or Fan and Anti-sweat Heater Thermostat (CT.4440353)	(5)	(K)	Koolgas Supplemental Drain Pan Heater – Bottom – (120V)	(11)		
<b>RELAYS</b>				<b>LED FIXTURES AND POWER SUPPLY</b>				
(F)	0342598	Control Relay (120V KoolGas) (RL.4480238)	(6)	J.	0499399		LED Power Supply (EP.4481668)	
(G)	0342599	Control Relay (208V) (RL.4480237)	(7)	K.			LED Fixture	
<b>HEATERS</b>				<i>Replace with like fixtures</i>				
(H)	Electric Defrost Heaters (208V)		(8)	<b>NOTE: For LED lighting parts contact your Hussmann service representative at 1-800-922-1919. Please have your model and serial number available. Descriptions including size and color are at <a href="http://WWW.HUSSMANN.COM/SERVICEANDPARTS">WWW.HUSSMANN.COM/SERVICEANDPARTS</a>.</b>				
	0461938	(1) 2 Door Models (HE.4850354)						
	0461939	(1) 3 Door Models (HE.4850355)						
	0461940	(1) 4 Door Models (HE.4850356)						
	0461941	(1) 5 Door Models (HE.4850357)						
(I)	Drain Pan Heater (Electric & Kool Gas) (120V)		(9)					
	0508199	(1) 2 Door Models (HE.4851029)						
	0508200	(1) 3 Door Models (HE.4851030)						
	0508201	(1) 4 Door Models (HE.4850987)						
	0508202	(1) 5 Door Models (HE.4850988)						

Refer to INNOVATOR REACH-IN GLASS DOOR INSTALLATION AND SERVICE manual, P/N 0425683, for Innovator, Innovator II, or Innovator III door and frame replacement parts.

**Note:** Rev. F adds EcoShine II LEDs. Other changes are marked by a bar in the margin.



# Engineering Plan Views

Refrigeration and electrical connections are on top.  
Overhead piping and electrical circuits are required.

## PHYSICAL DATA

Merchandiser Drip Pipe (in.)	1 1/4
Merchandiser Liquid Line (in.)	3/8
Merchandiser Suction Line (in.)	7/8

06-2009

### Tall Reach-In 2, 3, 4 & 5 Door

Dimensions shown as inches & (mm).

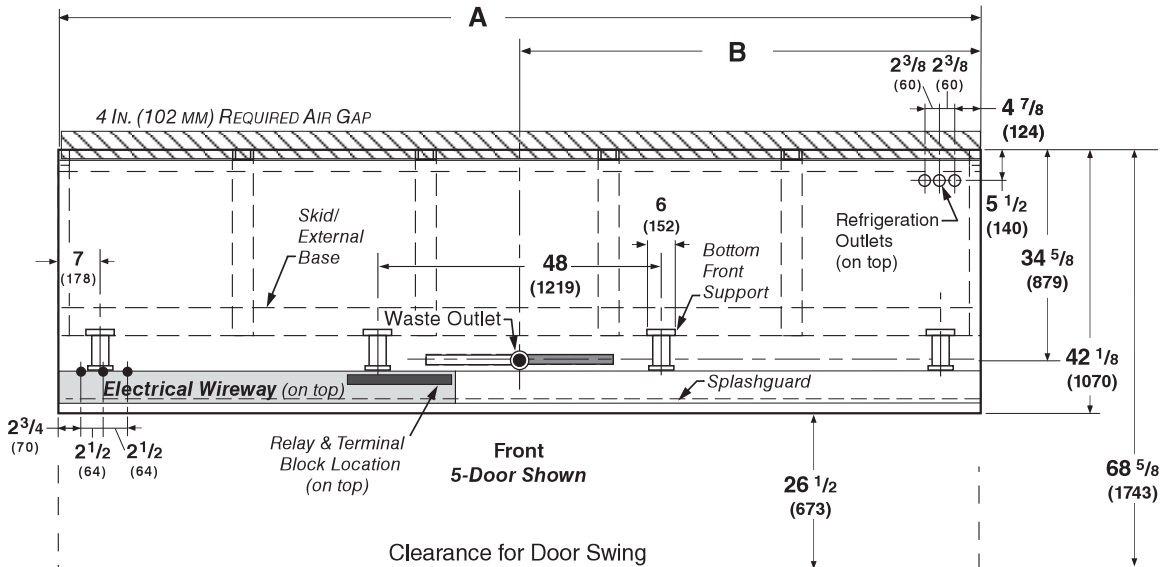

	2 Dr	3 Dr	4 Dr	5 Dr
<b>General</b>				
<b>(A) Case Length (without ends or partitions)</b>	62 (1575)	92 1/2 (2350)	122 7/8 (3121)	153 3/8 (3896)
<i>(Each solid end adds 2 in. (51 mm) to length of lineup; each window end or insulated partition adds 1 1/2 in. (38 mm).</i>				
Maximum outside dimension of case back to front <i>(Includes bumper)</i>	42 1/8 (1070)	42 1/8 (1070)	42 1/8 (1070)	42 1/8 (1070)
Back of case to front of splashguard	39 (991)	39 (991)	39 (991)	39 (991)
Width of Skid rail	3 3/4 (95)	3 3/4 (95)	3 3/4 (95)	3 3/4 (95)
Width of Bottom Front Support	6 (152)	6 (152)	6 (152)	6 (152)
Stub-up area between front Skid rail and splashguard	6 1/2 (165)	6 1/2 (165)	6 1/2 (165)	6 1/2 (165)
<b>Electrical Service</b>				
Left hand end of case to the center of nearest knockout	2 3/4 (70)	2 3/4 (70)	2 3/4 (70)	2 3/4 (70)
Right hand end of case to the center of center knockout	56 3/4 (1441)	87 1/4 (2216)	117 5/8 (2988)	148 1/8 (3762)
Back outside of case to center of knockout	31 5/8 (803)	31 5/8 (803)	31 5/8 (803)	31 5/8 (803)
Raceway Length	62 (1575)	62 (1575)	62 (1575)	62 (1575)
<b>*NOTE: Electrical Field Wiring Connection Point is at terminal.</b>				
<b>Waste Outlet</b>				
<b>(B) Right end of case to center of waste outlet</b>	23 7/8 (606)	54 1/4 (1378)	46 1/4 (1175)	76 5/8 (1946)
Back outside of case to center of waste outlet	34 5/8 (879)	34 5/8 (879)	34 5/8 (879)	34 5/8 (879)
<b>Water Seal</b>				
Edge of water seal to center of waste outlet	13 (330)	13 (330)	13 (330)	13 (330)
Schedule 40 drip piping	1 1/4 (32)	1 1/4 (32)	1 1/4 (32)	1 1/4 (32)
<b>** NOTE: Field installed water seal outlets, tees, and connectors are shipped with case.</b>				
<b>Refrigeration Outlet</b>				
RH end of case to center of RH refrigeration outlet	7 1/4 (184)	7 1/4 (184)	7 1/4 (184)	7 1/4 (184)
Back outside of case to center of refrigeration outlet	5 1/2 (140)	5 1/2 (140)	5 1/2 (140)	5 1/2 (140)
Outside bottom front supports from end of case	7 (178)	7 (178)	7 (178)	7 (178)
Center bottom front support from Centerline	24 (610)	24 (610)	24 (610)	24 (610)
<i>Distance between Center and Outside supports will vary.</i>				
<i>Top piping is standard in the RLT case.</i>				

**RLT**  
With Innovator Doors  
Low Temperature

Refrigeration and electrical connections are on top.  
Overhead piping and electrical circuits are required.

**REFRIGERATION DATA**

**Note:** This data is based on store temperature and humidity that does not exceed 75°F and 55% R.H.

	FF	IC
<b>Discharge Air (°F)</b>	-5	-12
<b>Evaporator (°F)</b>	-11	-19
<b>Unit Sizing (°F)</b>	-14	-22

**Btu/hr/Door\***

	FF	IC
<b>INNOVATOR</b>		
<b>Parallel</b>	1285	1360
<b>Conventional</b>	1310	1390

\* Optional Ecoshine 27W LED's add 20 Btu/hr/door.

**DEFROST DATA**

	FF	IC
<b>Frequency (hr)</b>	24	24
<b>Defrost Water (lb/Dr/day)</b>	1.2	1.3

(± 15% based on case configuration and product loading.)

<b>ELECTRIC</b>	FF	IC
<b>Temp Term (°F)</b>	54°	54°
<b>Failsafe (minutes)</b>	48	48

<b>GAS</b>	FF	IC
<b>Duration (minutes)</b>	22	22

**OFFTIME** Not Recommended

**CONVENTIONAL CONTROLS**

**Low Pressure Backup Control**

	FF	IC
<b>CI/CO (Temp °F)**</b>	-18°/-34°	-26°/-45°

**Indoor Unit Only, Pressure Defrost**

**Termination (Temp °F)\*\***  
Not Recommended

\*\*Use a Temperature Pressure Chart to determine PSIG conversions.

<b>Estimated Charge ***</b>	<b>RLT</b>		
<b>2 Dr</b>	3.2 lb	51 oz	1.5 kg
<b>3 Dr</b>	4.7 lb	75 oz	2.1 kg
<b>4 Dr</b>	6.3 lb	101 oz	2.9 kg
<b>5 Dr</b>	8.1 lb	130 oz	3.7 kg

\*\*\*This is an average for all refrigerant types. Actual refrigerant charge may vary by approximately half a pound (8 oz / 0.2 kg).

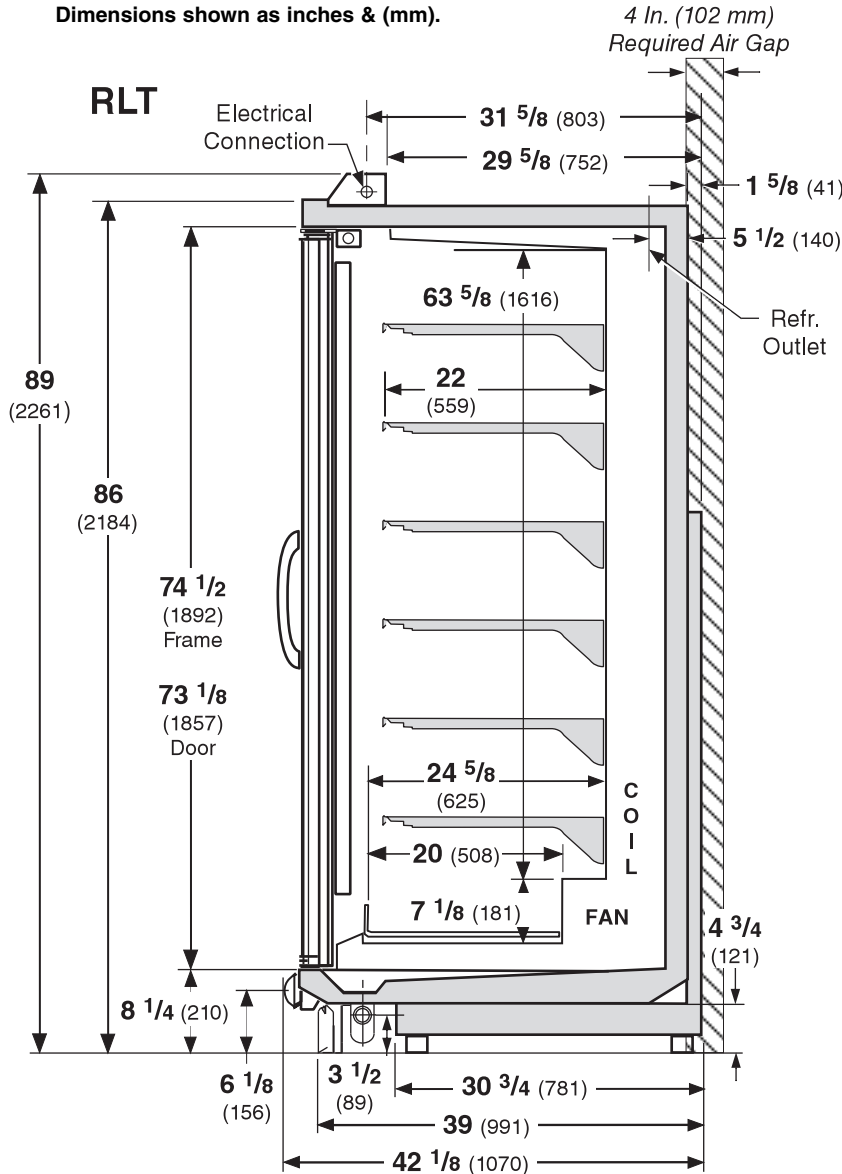

**NSF Certification**

This merchandiser model is manufactured to meet NSF/ANSI (National Sanitation Foundation) Standard #7 requirements for construction, materials & cleanability.

# RLT

With Innovator Doors  
Low Temperature

**Hussmann recommends against frame heater cycling with *Innovator* doors to prevent door seals from freezing to the frames and tearing.**

## Electrical Data

Number of Fans	2Dr	3Dr	4Dr	5Dr				
	2	3	4	5	Amperes		Watts	
	2Dr	3Dr	4Dr	5Dr	2Dr	3Dr	4Dr	5Dr
<b>Energy Efficient Evaporator Fan</b>								
120V 50/60Hz Innovator	0.8	1.3	1.7	2.7	100	150	200	250
220V 50/60Hz Export Innovator	0.3	0.45	0.6	0.75	36	54	72	90
<b>Door Anti-sweat Heaters (on fan circuit)</b>								
120V 50/60Hz Innovator	1.4	2.0	2.7	3.4	162	244	325	406
220V 50/60Hz Export Innovator	0.7	1.1	1.5	1.8	153	230	306	382
<b>Frame Anti-sweat Heaters (on fan circuit)</b>								
120V 50/60Hz Innovator	0.96	1.43	1.92	2.4	115	172	230	288
220V 50/60Hz Export Innovator	0.5	0.8	1.1	1.3	115	172	230	288
<b>Minimum Circuit Ampacity</b>								
120V 50/60Hz Innovator Electric Defrost	4.2	6.1	8.1	10.1				
120V 50/60Hz Innovator Koolgas Defrost	6.9	10.4	14.0	17.6				
220V 50/60Hz Exp Innovator Electric Defrost	2.3	3.5	4.6	5.6				
220V 50/60Hz Exp. Innovator Koolgas Defrost	3.8	5.8	7.8	9.6				
Maximum Over Current Protection 120V	20	20	20	20				
Maximum Over Current Protection 220V	20	20	20	20				

## Defrost

<b>Drain Heaters (Kool-Gas or Electric)</b>										
120V 50/60Hz Standard	1.0	1.5	2.0	2.5	120	180	240	300		
220V 50/60Hz Export	0.5	0.75	1.0	1.25	110	165	220	275		
<b>Kool-Gas Supplemental Heaters</b>										
120V 50/60Hz Standard	4.3	6.8	9.2	11.6	516	814	1102	1390		
220V 550/60Hz Export	2.4	3.7	5.0	6.3	472	744	1007	1270		
<b>Electric Defrost Heater</b>										
208V 50/60Hz Standard	7.7	11.5	15.4	19.2	1600	2400	3200	4000		
220V 50/60Hz Export	6.7	10.0	13.3	16.6	1465	2200	2930	3660		
<b>Standard Vertical LED Lighting 4100K</b>										
Hussmann EcoShine II™ [22 W] (120V)	0.36	0.54	0.72	0.90	43	65	86	108		
Hussmann EcoShine II™ [22 W] (220V Export)	0.20	0.29	0.39	0.49	43	65	86	108		
<b>Optional Vertical LED Lighting</b>										
Hussmann EcoShine™ [27 W] (120V)	0.45	0.68	0.90	1.13	54	81	108	135		
Hussmann EcoShine™ [27 W] (220V Export)	0.25	0.37	0.49	0.61	54	81	108	135		
Hussmann EcoShine™ EP [16 W] (120V)	0.27	0.40	0.53	0.67	32	48	64	80		
Hussmann EcoShine™ EP [16 W] (220V Exp)	0.15	0.22	0.29	0.36	32	48	64	80		
GE Illumination (120V)	0.30	0.45	0.60	0.75	36	54	72	90		
GE Illumination (220V Export)	0.16	0.25	0.33	0.41	36	54	72	90		

**Product Data**

<i>Recommended Usable Cube</i> <sup>1</sup> (Cu Ft/Dr)	24.95 ft <sup>3</sup> /Dr (0.71 m <sup>3</sup> /Dr)
<i>AHRI Total Display Area</i> <sup>2</sup> (Sq Ft/Dr)	13.59 ft <sup>2</sup> /Dr (1.26 m <sup>2</sup> /Dr)
<i>Shelf Area</i> <sup>3</sup> (Sq Ft/Dr)	32.38 ft <sup>2</sup> /Dr (3.01 m <sup>2</sup> /Dr)

<sup>1</sup> AHRI Refrigerated Volume less shelving and other unusable space: Refrigerated Volume/Unit of Length, ft<sup>3</sup>/ft [m<sup>3</sup>/m]  
<sup>2</sup> Computed using AHRI 1200 standard methodology: Total Display Area, ft<sup>2</sup> [m<sup>2</sup>]/Unit of Length, ft [m]  
<sup>3</sup> Shelf surface area is composed of bottom deck plus standard shelf complement, as shown in the Hussmann *Product Reference Guide*. The standard shelf complement for this model is (6) rows of 22-inch shelves.

ESTIMATED SHIPPING WEIGHT <sup>4</sup>						
Case	1 Dr	2 Dr	3 Dr	4 Dr	5 Dr	Solid End
						(each)
<b>lb (kg)</b>	NA (NA)	926 (420)	1290 (585)	1637 (743)	2006 (910)	60 (27)

<sup>4</sup> Actual weights will vary according to optional kits included.

# Fan and Heater Circuits - Electric Defrost (standard)

## Low Temperature

CIRCLED NUMBERS = PARTS LIST ITEM NUMBERS  
 R = Red P = Purple 2P = Purple (2 Bands) DB = Dark Blue BK = Black  
 LB = Light Blue Pink = Pink BR = Brown Y = Yellow OR = Orange W = White  
**THESE ARE MARKER COLORS (WIRE MAY VARY.)**

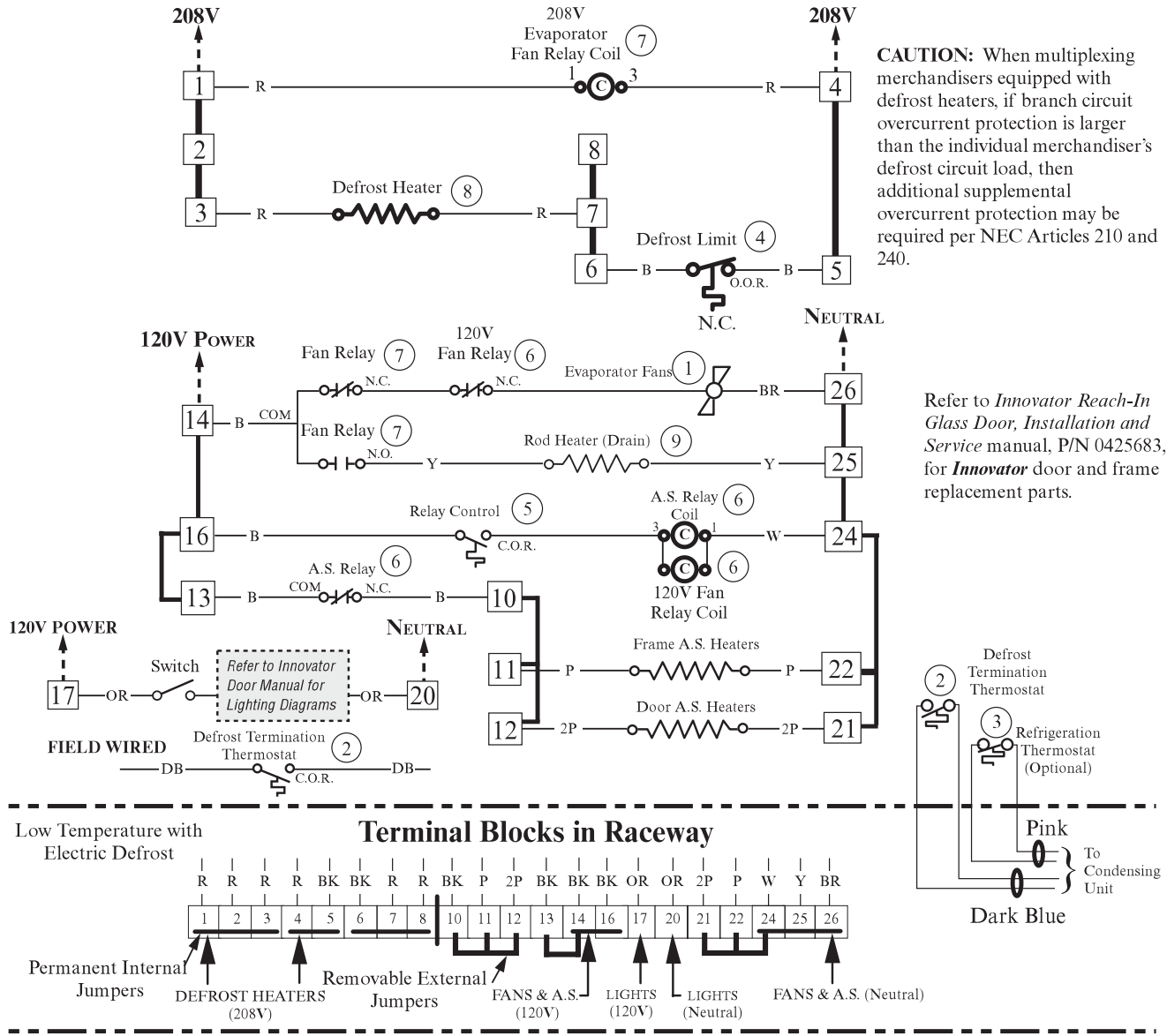

### Electric Defrost Sequence - Low Temperature

1. Power from the defrost contactor energizes Defrost Heaters and 208V Evaporator Fan Relay Coil (7). Relay Contacts open the fan circuit and energizes the Drain Pan Heater.
2. If the Defrost Heater raises internal air temperature above 90°F, the Defrost Limit Thermostat (4) will open.
3. Temperature rise of the evaporator closes the Relay Control Thermostat (5) at about 35°F, energizing 120V A.S. Relay Coils (6). These relays' contacts open the Frame and Door Heater Circuits, and prevent the Fan Circuit from energizing upon defrost termination.
4. When Defrost Termination Thermostat ends defrost period, the defrost contactor opens the Defrost Heater and Evaporator Fan Relay Coil Circuits. The Drain Pan Heater goes off.
5. Temperature fall of the evaporator opens the Relay Control Thermostat (5) at about 20°F, de-energizing 120V A.S. Relay Coils (6). A.S. Relay Contacts close the Frame and Door Heater Circuits, and Fan Circuit.

# Fan and Heater Circuits - Gas Defrost (optional) Low Temperature

CIRCLED NUMBERS = PARTS LIST ITEM NUMBERS  
 R = Red P = Purple 2P = Purple (2 Bands) DB = Dark Blue BK = Black  
 LB = Light Blue Pink = Pink BR = Brown Y = Yellow OR = Orange W = White  
**THESE ARE MARKER COLORS (WIRE MAY VARY)**

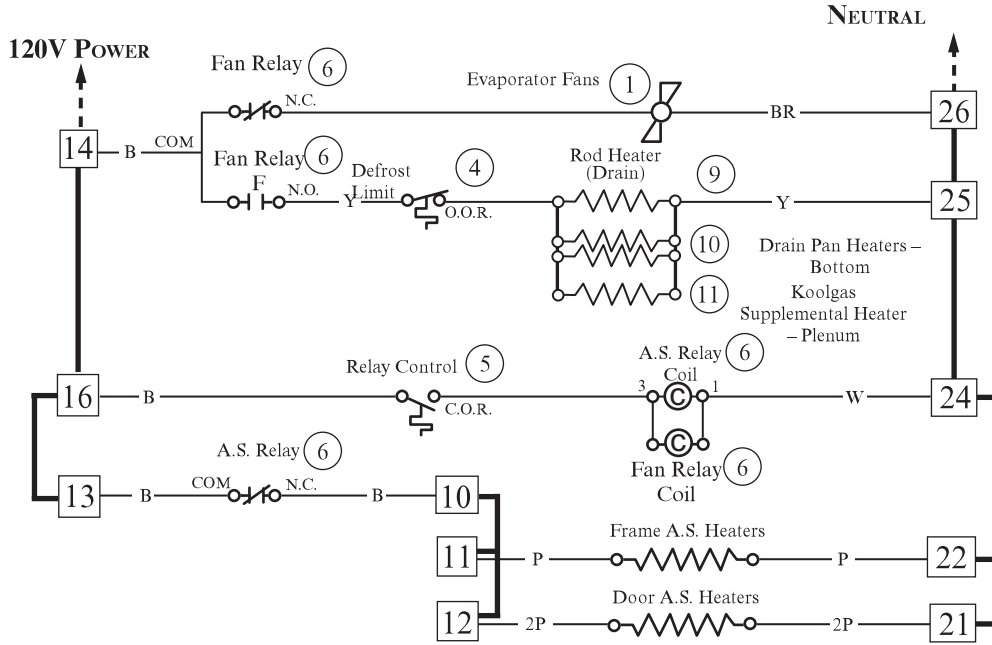

Refer to *Innovator Reach-In Glass Door, Installation and Service manual, P/N 0425683* for *Innovator* door and frame replacement parts.

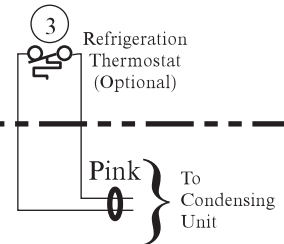
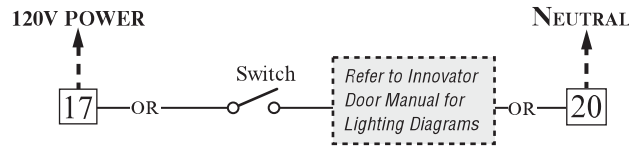

Low Temperature with Gas Defrost

## Terminal Blocks in Raceway

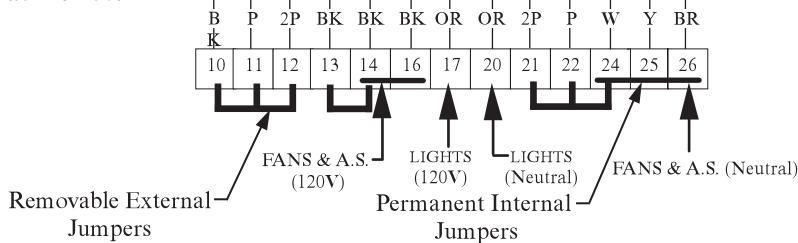

## Gas Defrost Sequence - Low Temperature

1. Defrost vapor enters evaporator causing a rise in temperature. At about 35°F the Control Relay Thermostat (5) closes the Fan Relay Coil and Control Relay Coil (6) circuit. The Coil opens the Fan, Door Heater, and Frame Heater circuits, while energizing the Drain Pan, Bottom, and Plenum Heaters (9), (10) and (11).
2. If the Drain Pan Heater (9) raises internal air temperature above 90°F, the Heater Limit Thermostat (4) will open.
3. When the defrost timer ends a defrost period, the evaporator temperature will start to fall. At about 20°F, the Control Relay Thermostat will open, de-energizing the Control Relay Coil and Fan Relay Coil (7). Control and Fan Relay's will open the Drain Pan Heater circuits, and will close the Fan, Door Heater, and Frame Heater circuits.

# RLT (220V) with INNOVATOR Doors

September 2011

120V Parts List is on Page 1.

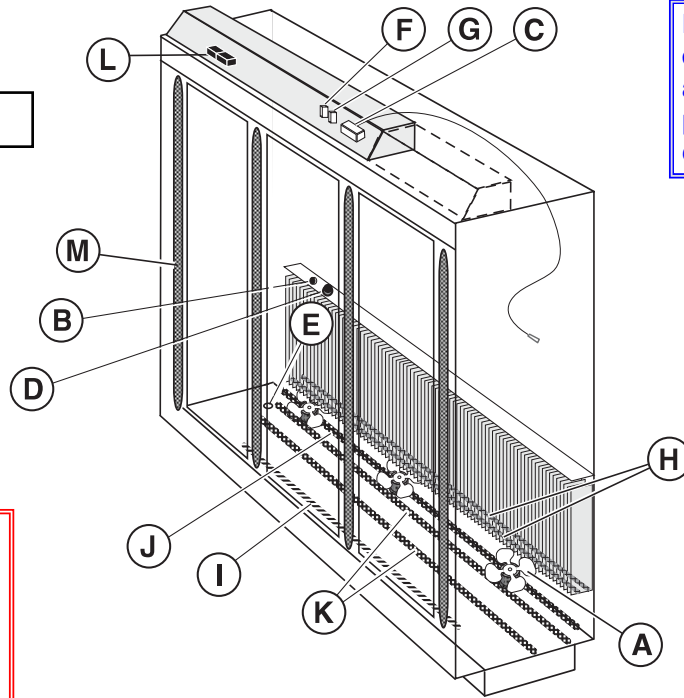

Refrigeration and electrical connections are on top. Overhead piping and electrical circuits are required.

We reserve the right to change or revise specifications and product design in connection with any feature of our products. Such changes do not entitle the buyer to corresponding changes, improvements, additions or replacements for equipment previously sold or shipped.

**Warning:**  
Terminal block NOT for case-to-case wire connection!

ItemPart #	Description	Wiring Item #	ItemPart #	(Qty)	Description	Wiring Item #
<b>FAN ASSEMBLIES, AND THERMOSTATS</b>						
(A)	Fan Assembly	(1)	(K)		Koolgas Supplemental Heater (220V) – Plenum	(11)
0435101	Standard Energy Efficient Motor (MO.4410574)		0460118	(1)	2 Door Models	
0315470	Fan Blade (FB.0315470)		0460119	(1)	3 Door Models	
(B)	0331798 Standard Non-adjustable Defrost Thermostat (CT.4440256)	(2)	0460120	(1)	4 Door Models	
(C)	Optional Adj. Refrigeration Thermostat	(3)	0460121	(1)	5 Door Models	
(D)	0440423 Defrost Limit Thermostat (CT.4481089)	(4)	(L)		Koolgas Supplemental Heater (220V) Drain Pan Bottom	(12)
(E)	0446007 Relay Control Thermostat or Fan and Anti-sweat Heater Thermostat (CT.4440353)	(5)	0460122	(2)	2 Door Models	
			0460123	(2)	3 Door Models	
			0460124	(2)	4 Door Models	
			0460125	(2)	5 Door Models	
<b>RELAYS</b>						
(F)	0342599 Control Relay (220V) (RL.4480237)	(6)	J.	0499399	LED Power Supply (EP.4481668)	
(G)	0342599 Control Relay (220V) (RL.4480237)	(7)	K.		LED Fixture	
(H)	0460133 Transformer (EP.4481557)	(8)			Replace with like fixtures	
<b>HEATERS</b>						
(I)	Electric Defrost Heaters (208V)	(9)	<b>LED FIXTURES AND POWER SUPPLY</b>			
0460114	(1) 2 Door Models		<i>NOTE: For LED lighting parts contact your Hussmann service representative at 1-800-922-1919. Please have your model and serial number available. Descriptions including size and color are at <a href="http://WWW.HUSSMANN.COM/SERVICEANDPARTS">WWW.HUSSMANN.COM/SERVICEANDPARTS</a>.</i>			
0460115	(1) 3 Door Models					
0460116	(1) 4 Door Models					
0460117	(1) 5 Door Models					
(J)	Drain Pan Heater (220V) Electric & Kool Gas	(10)				
0460110	(1) 2 Door Models					
0460111	(1) 3 Door Models					
0460112	(1) 4 Door Models					
0460113	(1) 5 Door Models					

Refer to INNOVATOR REACH-IN GLASS DOOR INSTALLATION AND SERVICE MANUAL, PIN 0425683, for Innovator door and frame replacement parts.