

We reserve the right to change or revise specifications and product design in connection with any feature of our products. Such changes do not entitle the buyer to corresponding changes, improvements, additions or replacements for equipment previously sold or shipped.

Item	Part #	Description	Wiring Item #	Item	Part #	Description	Wiring Item #
<b>FAN ASSEMBLIES AND THERMOSTATS</b>				<b>HEATERS</b>			
A.	<b>6W Fan Assembly</b>		(1)	C.	Canopy Anti-Sweat Heater		(3)
	0058698	Fan Motor, Evaporator		NA	4 ft		
	0142780	Fan Blade embossing toward motor		0109417	6 ft		
				0109417	8 ft		
				0109418	12 ft		
B.	0137880	Optional Adjustable Refrigeration Thermostat	(2)	<b>LAMPS AND BALLASTS</b>			
				D.	Ballast, Electronic		(4)
				0376409	2 lamps		
				0376410	3 lamps		
				E.	Fluorescent Lamp		(5)
					<i>Replace with like fixtures</i>		

**Note: Changes are NOT underlined.**  
**Revision A** added the canopy anti-sweat heater (pages 1, 4, 5 & 8); added 4-ft and 6-ft data (pages 1, 2, 3 & 4); and updated wiring diagrams.  
**Revision B** returned the correct data to page 3.  
**Revision C** returned the correct data to page 1.

# Engineering Plan Views

Dimensions shown as inches and (mm).

## Dairy / Delicatessen Precut & Packaged Produce

05-2003

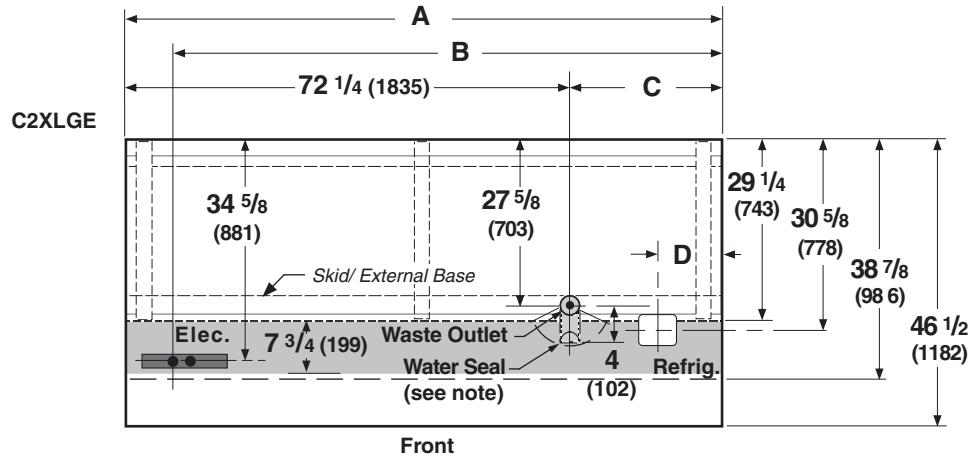

	4 ft	6 ft	8 ft	12 ft
<b>General</b>				
(A) Case Length <i>(without ends or partitions)</i> <i>(Each end and insulated partition adds 1 1/2 in. (38 mm) to case line up.)</i>	48 1/4 (1226)	72 3/8 (1838)	96 3/8 (2448)	144 1/2 (3670)
Maximum O/S dimension of case				
back to front <i>(includes bumper)</i>	46 1/2 (1182)	46 1/2 (1182)	46 1/2 (1182)	46 1/2 (1182)
Back of case to front of splashguard	38 7/8 (986)	38 7/8 (986)	38 7/8 (986)	38 7/8 (986)
Back of case to O/S edge of front skid rail	29 1/4 (743)	29 1/4 (743)	29 1/4 (743)	29 1/4 (743)
Width of skid rail	4 1/2 (114)	4 1/2 (114)	4 1/2 (114)	4 1/2 (114)
RH end of case to outside edge of external support	5 1/2 (140)	5 1/2 (140)	5 1/2 (140)	5 1/2 (140)
Distance between edges of external and center supports	NA	31 1/8 (790)	40 5/8 (1032)	40 5/8 (1032)
Distance between edges of center supports	41 1/4 (1048)	NA	NA	44 (1118)
Stub-up area between front skid rail and splashguard	7 3/4 (199)	7 3/4 (199)	7 3/4 (199)	7 3/4 (199)
<b>Electrical Service</b> <i>(Electrical Field Wiring connection point)</i>				
(B) RH End of case to center of farthest knockout	38 1/4 (972)	64 3/8 (1635)	88 3/8 (2245)	136 1/2 (3467)
Back O/S of case to center of knockout	34 5/8 (881)	34 5/8 (881)	34 5/8 (881)	34 5/8 (881)
Length of electrical raceway	16 1/8 (410)	34 1/2 (876)	35 5/8 (903)	35 5/8 (903)
<b>Waste Outlet</b>				
(C) RH End of case to the center of waste outlet	24 1/8 (613)	24 1/8 (613)	24 1/8 (613)	72 1/4 (1835)
LH End of case to the center of waste outlet	24 1/8 (613)	48 1/4 (1226)	72 1/4 (1835)	72 1/4 (1835)
<b>Water Seal</b>				
Edge of water seal to center of waste outlet	4 (102)	4 (102)	4 (102)	4 (102)
Outside diameter of the drip pipe	1 1/2 (38)	1 1/2 (38)	1 1/2 (38)	1 1/2 (38)
<i>Note: Water seal outlet must clear front skid rail.</i>				
<b>Refrigeration Outlet</b>				
Back of case to center of refrigeration outlet	30 5/8 (778)	30 5/8 (778)	30 5/8 (778)	30 5/8 (778)
(D) RH end of case to center of refrigeration outlet	9 (230)	9 (230)	9 (230)	9 (230)

Dimensions shown as inches and (mm).

**Impact C2-XLGEP**  
**Dairy / Delicatessen**  
**Precut & Packaged Produce**

**REFRIGERATION DATA**

**Note:** This data is based on store temperature and humidity that does not exceed 75°F and 55% R.H.

C2-XLGEP	UNLIT	LIT
Discharge Air (°F)	32	30
Evaporator (°F)	28	26
Unit Sizing (°F)	26	24

Btu/hr/ft*	UNLIT	LIT
Parallel	775	850
Conventional	805	885

\*For all refrigeration equipment other than Hussmann, use conventional Btu values.

**DEFROST DATA**

	C2-XLGEP
Frequency (hr)	12
Defrost Water (lb/ft/day)	7
(± 15% based on case configuration and product loading).	

OFFTIME	C2-XLGEP
Time (minutes)	30

**ELECTRIC OR GAS** Not Recommended

**CONVENTIONAL CONTROLS**

Low Pressure Backup Control	C2-XLGEP
CI/CO**	19°F / 9°F

**Indoor Unit Only, Pressure Defrost Termination\*\*** 48°F

\*\*Use a Temperature Pressure Chart to determine PSIG conversions.

**PHYSICAL DATA**

Merchandiser Drip Pipe (in.)	1 1/2
Merchandiser Liquid Line (in.)	3/8
Merchandiser Suction Line (in.)	7/8

**Estimated Charge (lb)\*\*\***

4 ft	1.6
6 ft	2.3
8 ft	3.2
12 ft	4.5

\*\*\*This is an average for all refrigerant types. Actual refrigerant charge may vary by approximately half a pound.

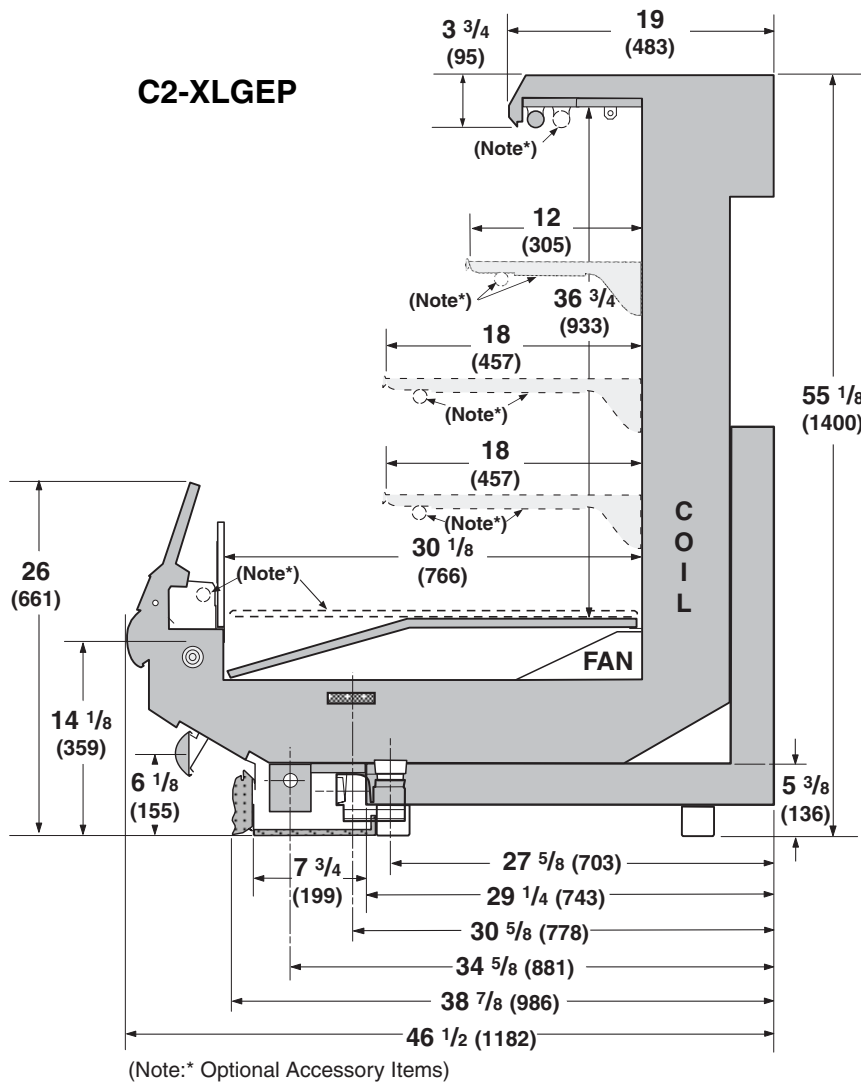

**NSF Certification**

These merchandisers are manufactured to meet ANSI /National Sanitation Foundation (NSF®) Standard #7 requirements.

<b>Impact C2-XLGEP</b> <b>Dairy / Delicatessen</b> <b>Precut &amp; Packaged Produce</b>
---

### Electrical Data

	<b>4 ft</b>	<b>6 ft</b>	<b>8 ft</b>	<b>12 ft</b>						
<b>Number of Fans—6W</b>	<b>1</b>	<b>2</b>	<b>2</b>	<b>3</b>						
		<b>Amperes</b>					<b>Watts</b>			
	<b>4 ft</b>	<b>6 ft</b>	<b>8 ft</b>	<b>12 ft</b>	<b>4 ft</b>	<b>6 ft</b>	<b>8 ft</b>	<b>12 ft</b>		
<b>Evaporator Fan</b>										
120V 60Hz Standard	0.50	1.00	1.00	1.50	39	78	78	117		
120V 50Hz Standard	0.55	1.10	1.10	1.65	42	84	84	126		
230V 60Hz Export	0.25	0.50	0.50	0.75	40	80	80	120		
230V 50Hz Export	0.28	0.56	0.56	0.84	44	88	88	132		
120V 60Hz Energy Efficient	0.26	0.52	0.52	0.78	18	36	36	54		
230V 60Hz Energy Efficient	NA									
<b>Canopy Anti-sweat Heaters</b>	NA	0.75	0.75	1.00	45	90	90	120		
<b>Minimum Circuit Ampacity</b>										
120V 60Hz Standard	0.70	1.95	1.95	2.70						
120V 50Hz Standard	0.75	2.05	2.05	2.85						
230V 60Hz Export	0.45	1.45	1.45	1.95						
230V 50Hz Export	0.48	1.51	1.51	2.04						
120V 60Hz Energy Efficient	0.46	1.47	1.47	1.98						
230V 60Hz Energy Efficient	NA									
<b>Maximum Over Current Protection 120V</b>	<b>20</b>	<b>20</b>	<b>20</b>	<b>20</b>						
Maximum Over Current Protection 230V	15	15	15	15						
<b>Standard Lighting</b>										
1 Row Canopy	0.26	0.51	0.51	0.77	30	59	59	85		
<b>Optional Lighting</b>										
Additional 1 Row Canopy	0.26	0.51	0.51	0.77	30	59	59	85		
Additional 2 Row Canopy	0.51	1.02	1.02	1.54	59	118	118	170		
1 Row Rail Light	0.26	0.51	0.51	0.77	30	59	59	85		
1 Row Ledge Light	0.26	0.51	0.51	0.77	30	59	59	85		
<b>Optional Shelf Lighting</b>										
1 Row Shelf Receptacle	0.26	0.51	0.51	0.77	30	59	59	85		
2 Row Shelf Receptacle	0.51	1.02	1.02	1.53	59	118	118	177		

115V Lighting Circuit Total = Standard Lighting + Total Optional Lighting + Optional Shelf Lighting

230V Lighting Circuit Total = Multiply 115V Lighting Circuit Total by 0.52

# 1, 2 & 3 Fans

- 4 ft — 1 Fan
- 6 ft — 2 Fans
- 8 ft — 2 Fans
- 12 ft — 3 Fans

## Fan Wiring Offtime Defrost

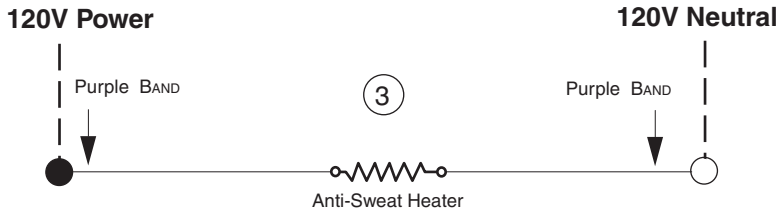
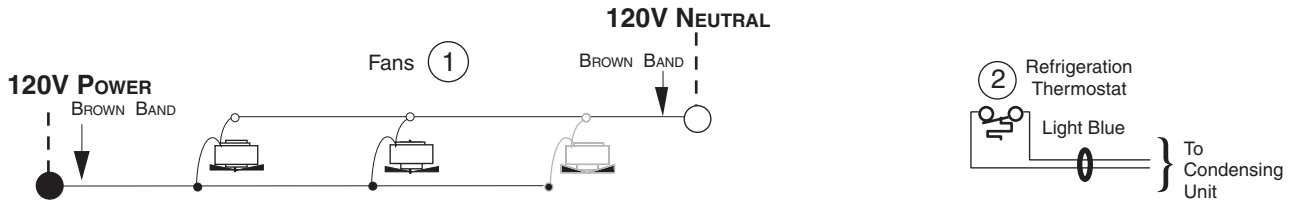

## Canopy Anti-Sweat Heater

# Optional Shelf Harness and Light Circuits for One Row of Shelves

## Shelf Lighting

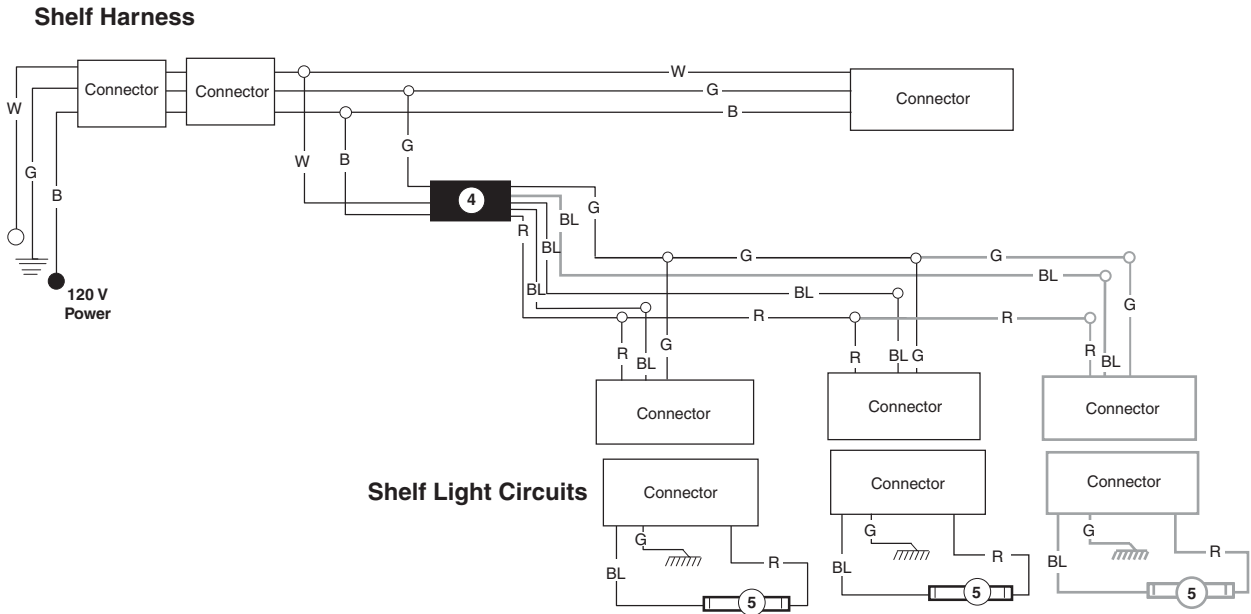

### WARNING

All components must have mechanical ground, and the merchandiser must be grounded.

CIRCLED NUMBERS = PARTS LIST ITEM NUMBERS

Grayed components in 12 foot models only.

R = Red Y = Yellow G = Green BL = Blue B = Black W = White

● = 120V POWER    ○ = 120V NEUTRAL    ≡ = Field GROUND    ≡≡ = Case GROUND

# Light Circuits

## Standard Lighting 1 Row Canopy or Optional 1 Row Rail

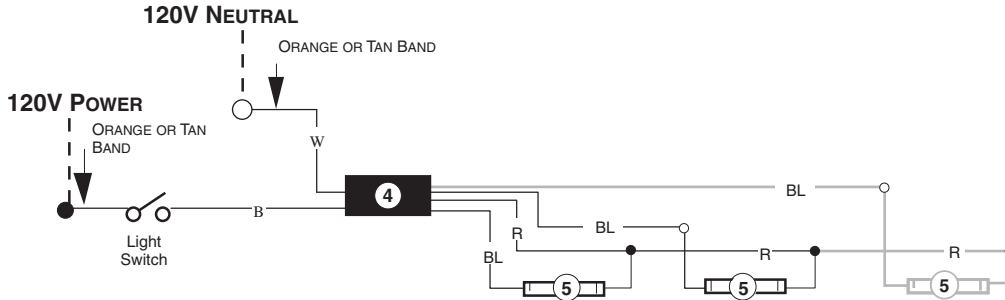

## Optional Lighting 2 Rows Canopy

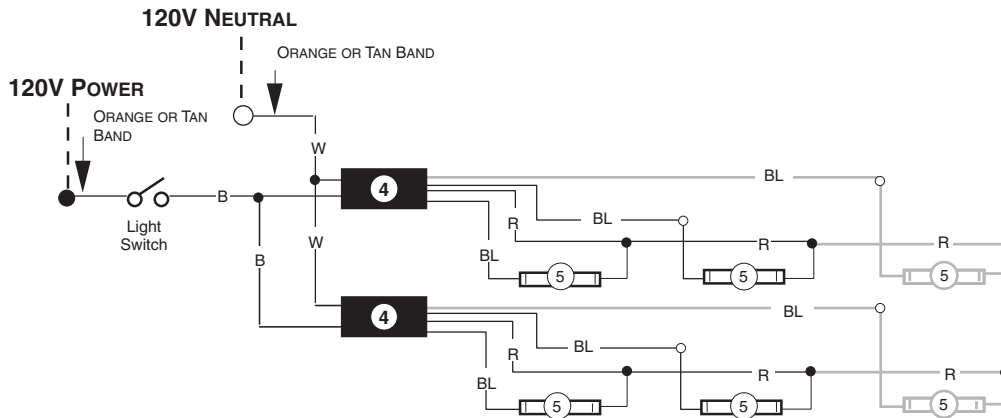

### WARNING

All components must have mechanical ground, and the merchandiser must be grounded.

CIRCLED NUMBERS = PARTS LIST ITEM NUMBERS

Grayed components in 12 foot models only.

R = Red Y = Yellow G = Green BL = Blue B = Black W = White

● = 120V POWER ○ = 120V NEUTRAL

**Impact C2-XLGEP**  
**Dairy / Delicatessen**  
**Precut & Packaged Produce**

**SHELF CONFIGURATION**

This merchandiser is designed for one, two or three shelves.

The depth of the shelf used in the top eight (8) shelf hole locations is critical to case performance.

If a shelf is placed in one of the top eight (8) locations it must comply with the angle/depth requirements listed below.

Shelf Angle	Maximum Shelf Depth
0°	12 in.
15°	14 in. or less
30°	18 in. or less
45°	18 in. or less

**NOTE:** Shelves placed in the lower positions may be up to 18 in. deep when positioned at a 0° angle.

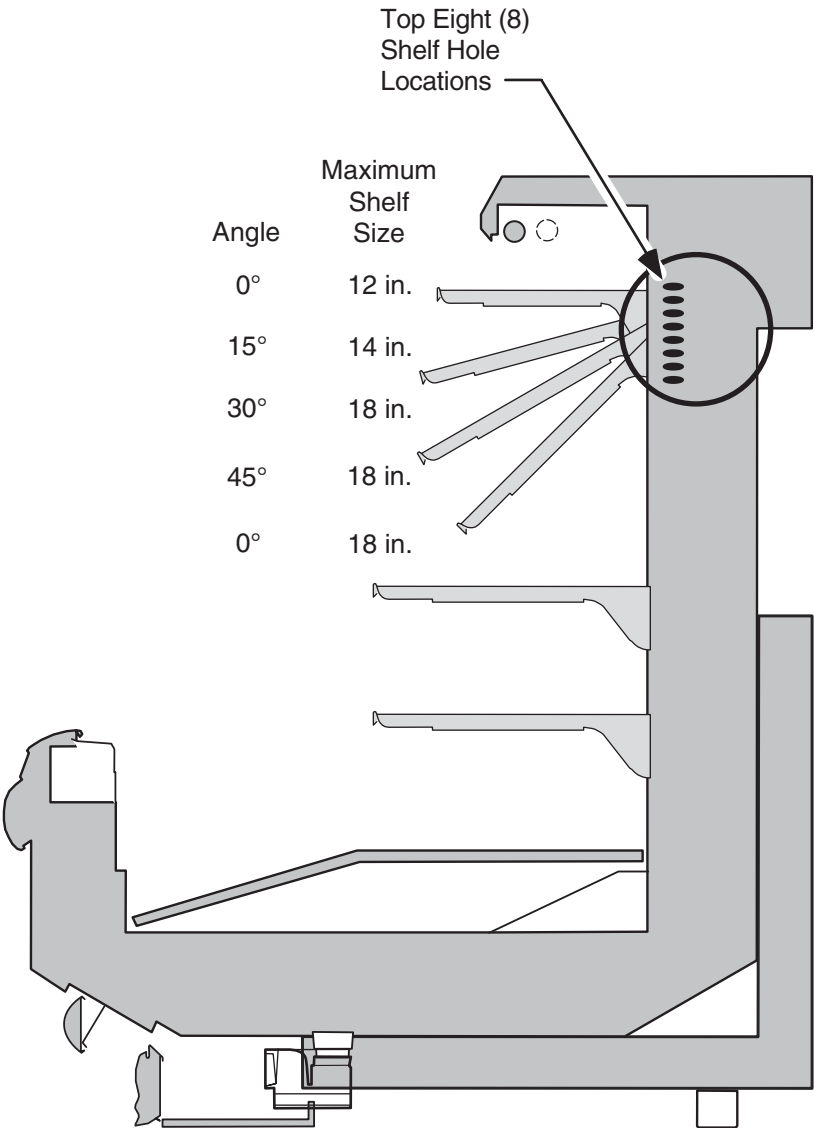

**Impact C2-XLGEP**  
**Dairy / Delicatessen**  
**Precut & Packaged Produce**

**CANOPY AND SHELF LAMP BALLAST**

The ballast for the canopy and shelf lamps is located behind the canopy on the left-hand end (when facing case) of the merchandiser.

To access the ballast:

1. Remove screws at bottom edge of canopy and rear of top panel.
2. Remove the canopy by pulling it forward.
3. Remove the top panel by lifting it up.
4. Service or replace ballasts as required.
5. Reassemble items as they were originally installed.

**NOTE:** Rail lamp ballast is located behind the lower front panel.

**CANOPY ANTI-SWEAT HEATER**

The canopy anti-sweat heater location is shown below. Connections are in the Electrical wireway.

