

HUSSMANN® Excel

For Medium Temperature Merchandisers

*Joining Instruction for
Medium Temperature
Single Deck and
Multi-Deck Merchandisers*

PARTS LIST

Item No.	Single Deck Quantity	Multi Deck Quantity	Description
1.	1	1	Gasket 1/2 x 1 x 180
2.	1	1	Gasket 1/2 x 15/8 x 120
3.	2	2	Front Rail Alignment Rod
4.	2	2	Alignment Pin
5.	1	3	Cap Screws 5/16 - 18 x 1 1/4
6.	2	2	Cap Screws 5/16 - 18 x 3 1/2
7.	—	2	Machine Screws #10 - 18 x 1 1/4
8.	6	10	Flat Washer
9.	6	10	Lock Washer
10.	3	5	Hex Nut 5/16 - 18
11.	4	4	Neoprene Washer 5/16 x 2 in.
12.	4	4	Fender Washer 5/16 x 2 in.
13.	1	1	Butyl Tape
14.	2	2	Splashguard Bracket
15.	1	1	Splashguard Joint Support
16.	8	8	Self-Drilling Screw Hex Head 5/16 x 1 in.

Note: Nut retainers are factory installed in the left end, and alignment pins are factory installed in the right end of merchandiser. (Merchandisers with front glass and/or front rail light require only one alignment rod. Merchandisers with low fronts do not require splashguard joint support.)

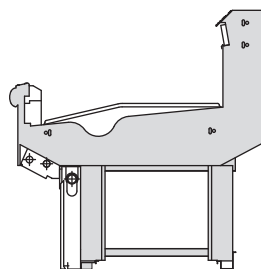

Single Deck



Multi-Deck

P/N 0460146_B
March 2012

JOINING

Sectional construction means that two or more merchandisers may be joined in line yielding one long continuous display requiring one pair of ends.

ALL JOINTS MUST BE AIR-TIGHT TO PREVENT FORMATION OF ICE OR CONDENSATION.

NOTE: Front glass panel may need adjustment before joining. Refer to Installation & Operation manual 043880_E, Page 1-18. Merchandisers with optional front rail light must have end caps installed, Page 1-19.

1 Prep Merchandiser

- Be sure merchandisers have been leveled according to the installation instructions to ensure good fit and finish of the lineup.
- Remove shelves (if installed), display racks, pans and front air grilles from the right end.
- Use a narrow ($\frac{3}{32}$ in. or smaller) rod to lift the honeycomb and remove it from its retainer as shown below.

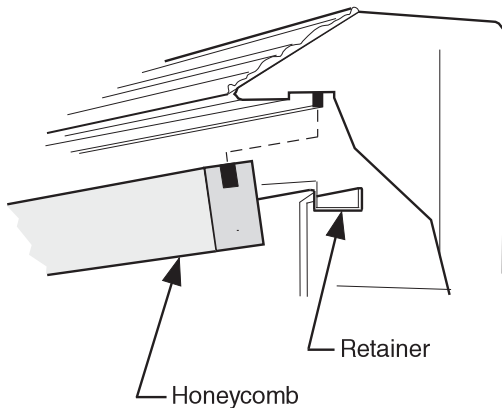

Figure 1. Removing Honeycomb

- Remove the rear interior panel(s) from the right end. On multi-deck merchandisers remove the lower back panel first. To remove a panel, lift it up from its bottom edge and out. No tools required.

2 Apply Gaskets as Follows:

Right End

- Apply the 1 inch (25 mm) gasket around the perimeter of the merchandiser as shown. It must be at the edge. Check that there are no gaps between gasket and merchandiser.
- Apply the $1\frac{5}{8}$ in. (41 mm) gasket so that one edge is on the metal merchandiser frame and the parallel edge laps the 1 inch gasket. Check to be sure that there are no gaps between merchandiser and gaskets.

IMPORTANT

- Do not stretch gasket, especially around corners.
- Do not butt gaskets; always overlap them as shown.
- Remove paper backing after gasket has been applied.
- *Perimeter gasket required by NSF.*
- End caps required for rail light.

NOTE:

Maintain a 3 inch air space between merchandiser and wall to prevent condensation.

A continuous bead of silicone sealant/caulk may be used in addition to gaskets on mating surfaces but must not be used in lieu of gaskets.

Gasket Detail Views

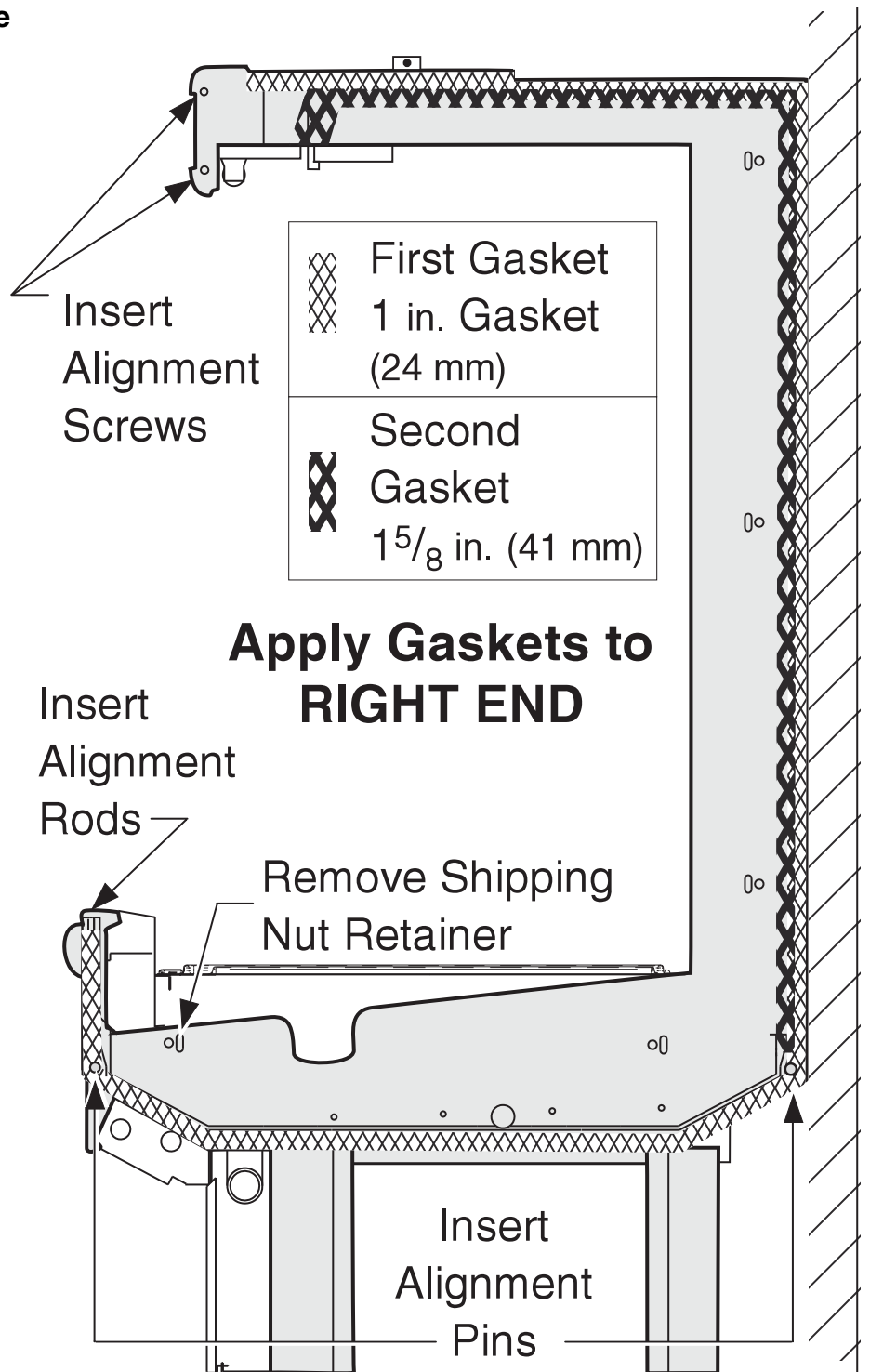
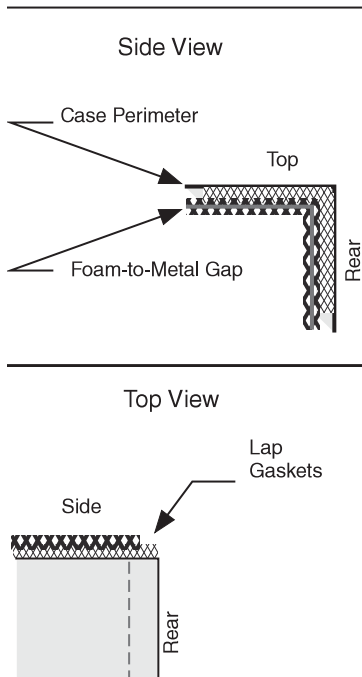

Figure 2. Multi-deck Gasket Installation

NOTE:
Maintain a 3 inch air space
between merchandiser
and wall to prevent
condensation.



First Gasket
1 in. (24 mm)



Second Gasket
1⁵/₈ in. (41 mm)

A continuous bead of
silicone sealant/
caulk may be used in
addition to gaskets on
mating surfaces but
must not be used in
lieu of gaskets.

Insert
Alignment
Rod

**Apply Gaskets to
RIGHT END**

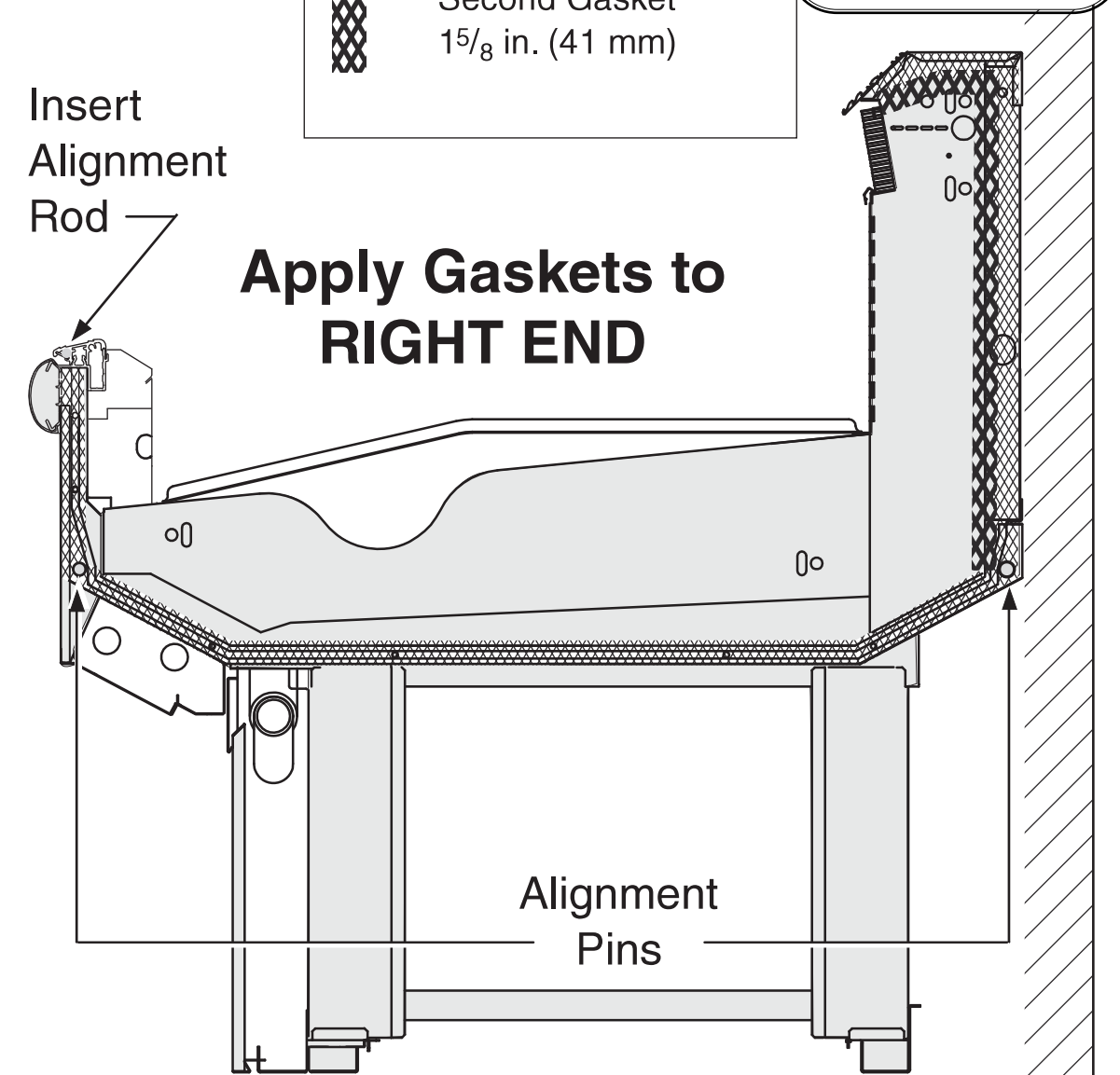
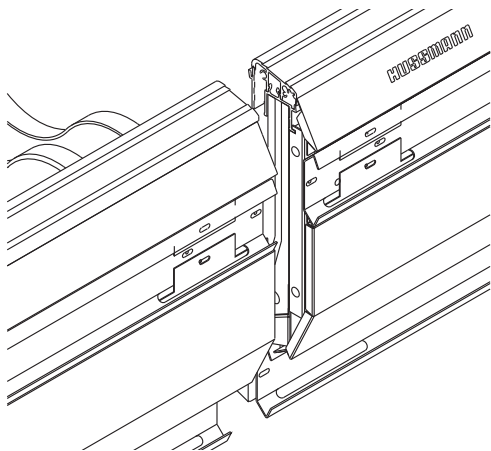

Figure 3. Single Deck Gasket Installation

3 Align End Frames

- a. Insert alignment pin at lower front and lower back. Verify nut retainers are installed in the right-hand end of the left merchandiser.
- b. Remove factory-installed nut retainers (if installed) from right end frame(s). Refer to Figure 2.
- c. *Move the second merchandiser as close to the first as possible by pushing or using lever bar (mule).*
- d. Insert the alignment rod ($\frac{1}{4}$ in. diameter x 6 in.) through hole in top rail, align and insert into second alignment rod to rail. Refer to Figure 4 on the next page.
- e. Match alignment pins with corresponding holes in foam bottom and canopy.
- f. **It is critical to verify that each merchandiser's upper front panel, front panel, and top rail align *before* joining merchandisers. Panels and top rail must have equal overhang at each end of the merchandiser.**



To correct vertical alignment of top rails and upper front panel, adjust adjustable legs and shims as necessary.

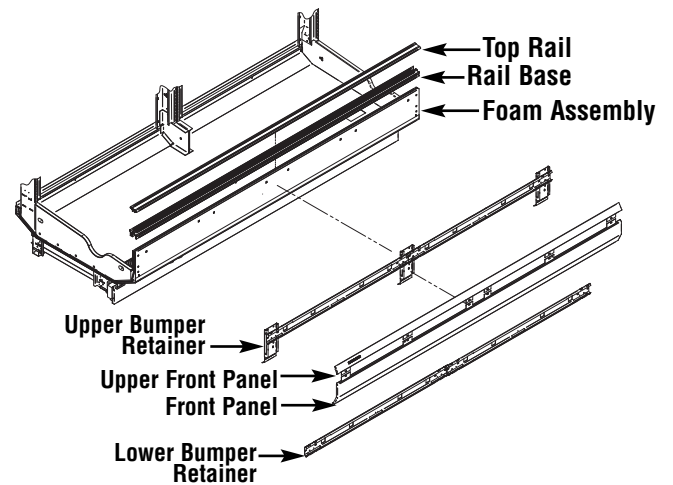

To correct horizontal alignment of upper front panel and lower front panel, remove the upper bumper to access screws attached to the front panels. Once these screws are loosened, the merchandiser's upper front panel and lower front panel can be adjusted horizontally.

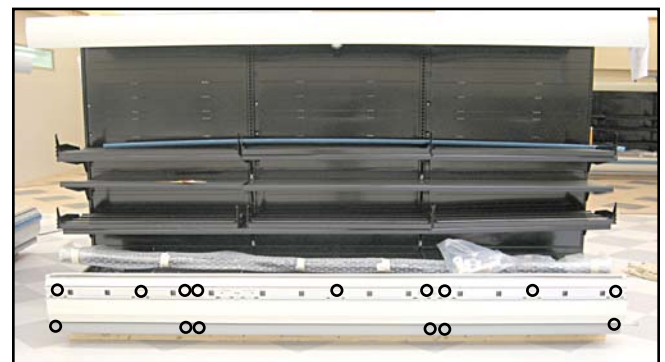

○ Screw Locations

IMPORTANT:

ALIGNMENT ORDER IS DIFFERENT FROM TIGHTENING ORDER!

REFER TO ALIGNMENT DIAGRAM AND DETAIL VIEWS ON THE NEXT THREE PAGES.

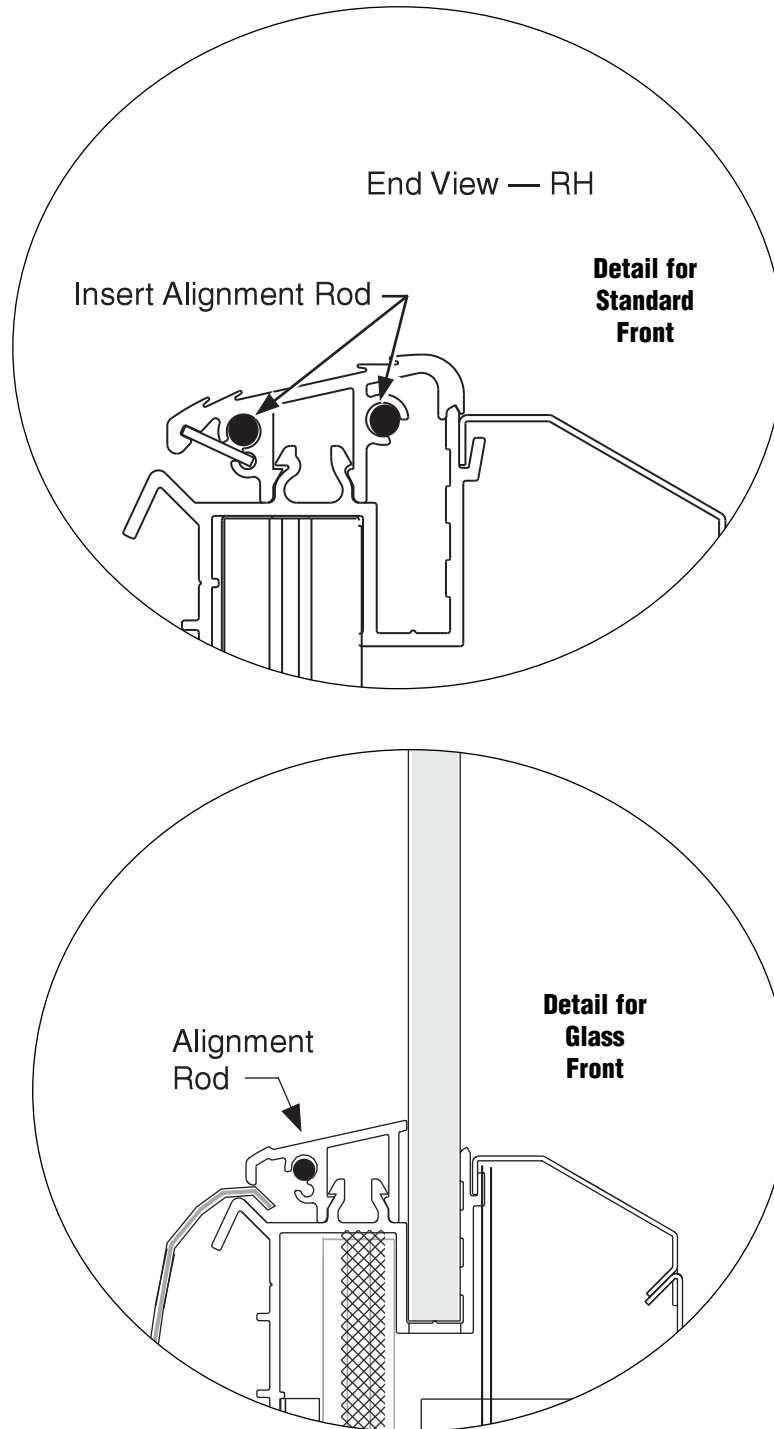
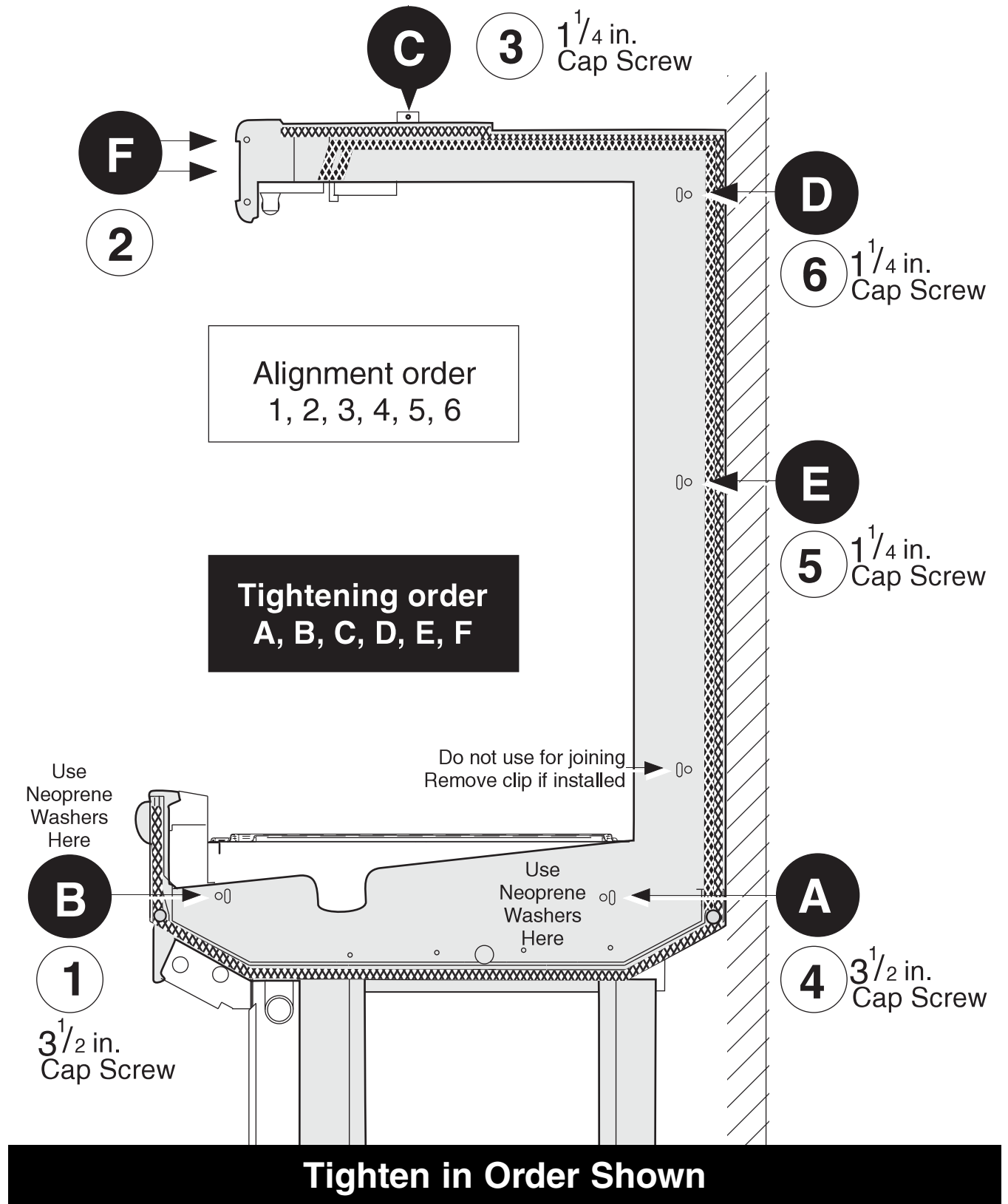
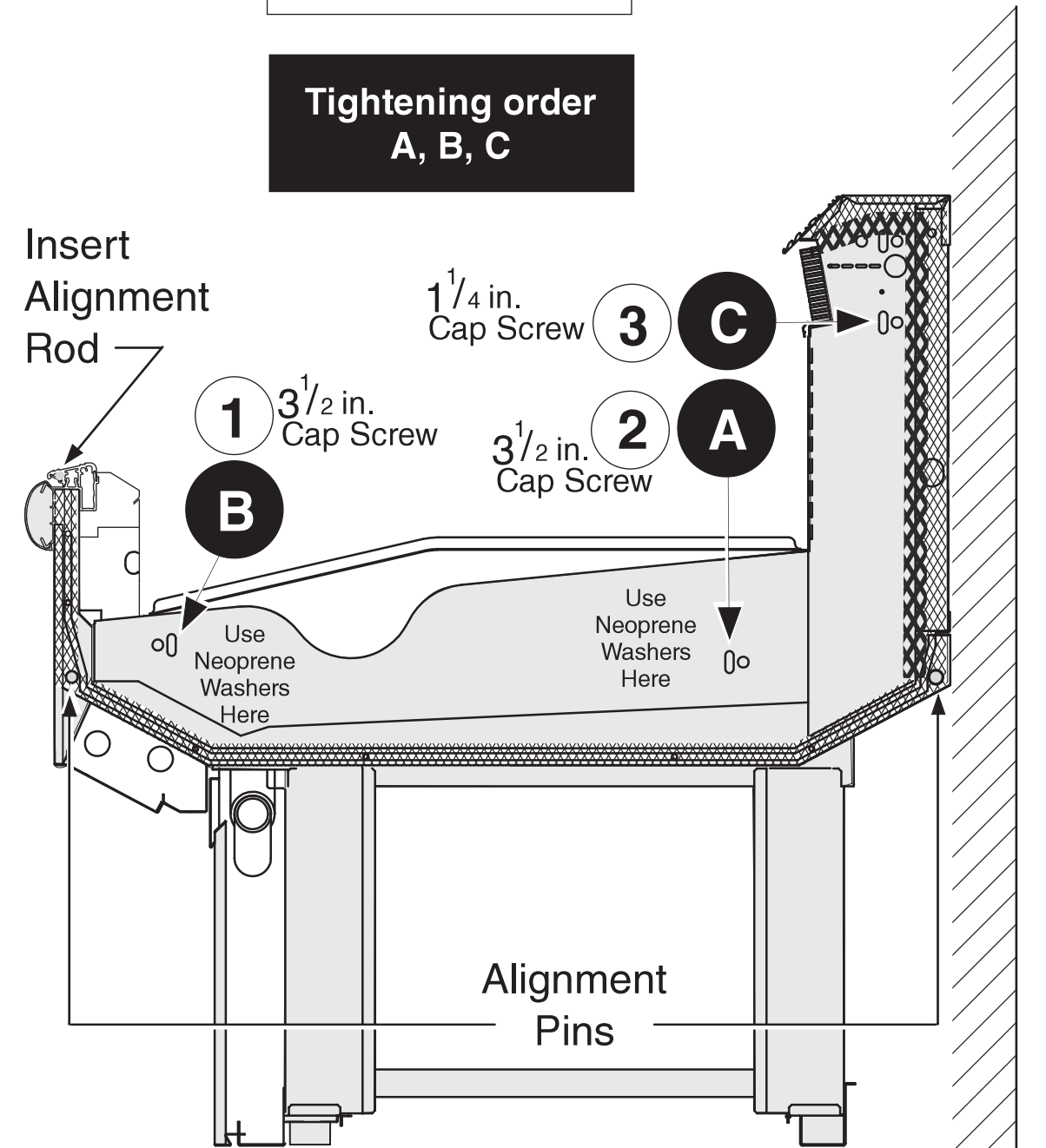

Figure 4. Alignment Rod Installation



Alignment order
1, 2, 3

Tightening order
A, B, C



Tighten in Order Shown

g. Use the shorter 1¹/₄ in. cap screws to fasten the back and canopy locations. Use the two (2) longer 3¹/₂ in. cap screws to draw the case together at the bottom.

h. In both holes in bottom shoe, place a 2 inch neoprene washer between end frame and metal washer of each merchandiser. Loosely assemble bolt, washers, lockwasher and nut as shown below.

DO NOT TIGHTEN FULLY.
Do not attempt to draw merchandisers together using nut and bolt.

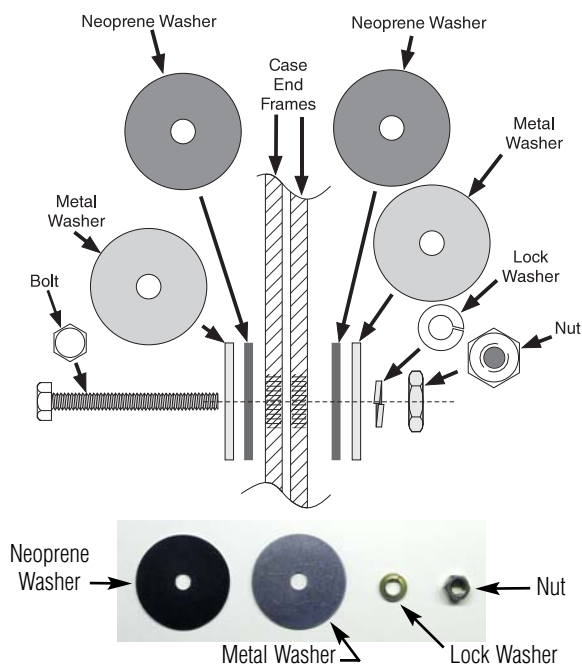

4 Aligning Canopy (multi-deck)

a. Insert a machine screw (#10 x 1¹/₄ in.) through each hole in canopy end cap, align and insert into joining canopy end cap. Fasten with nuts. See detail at top right. **Do not tighten fully.**

b. Draw canopies of multi-deck wall merchandisers together by using a bolt, flat washers, lockwasher and nut in the joining brackets atop the canopy. See detail at top right. **Tighten only until canopies touch.**

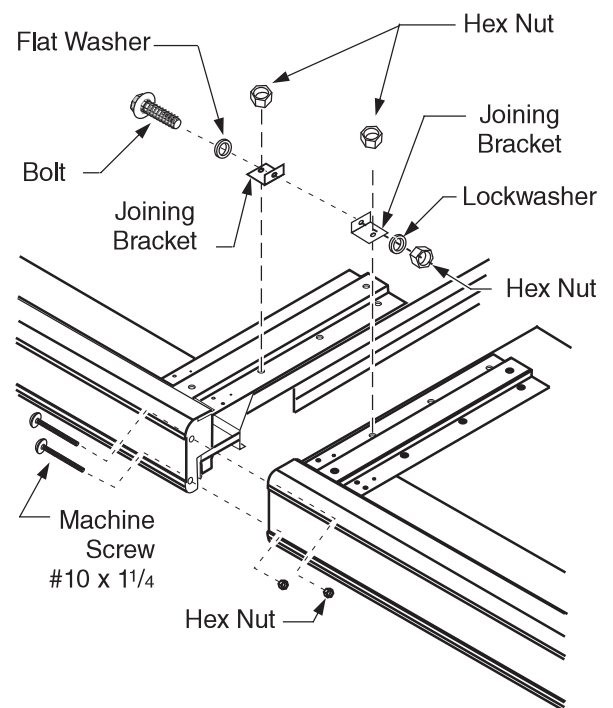

**Detail for Connecting Canopies
of Multi-deck Wall Merchandisers**

5 Fasten End Frames (single deck)

- Begin at lower back to draw end frames tight.
- Tighten joints in the order shown (A, B, C) until gaskets are compressed and merchandisers join smoothly.

6 Apply Butyl Tape / Silicone

- Remove wire shelf, interior front panel, and interior panel support bracket to apply butyl tape.

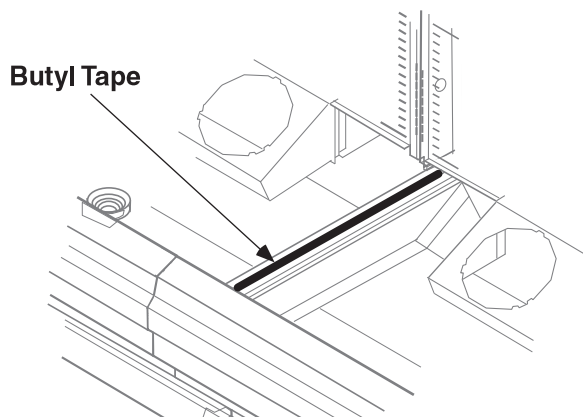
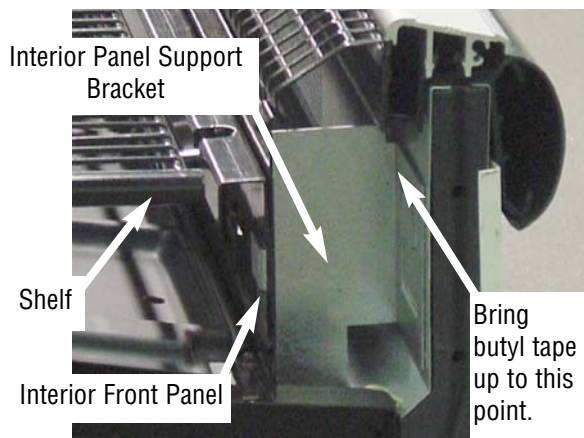

- Apply butyl tape along joint as shown in the illustration above.

7 Install Splashguard Joint Support

Install splashguard joint support as shown in the illustration below.

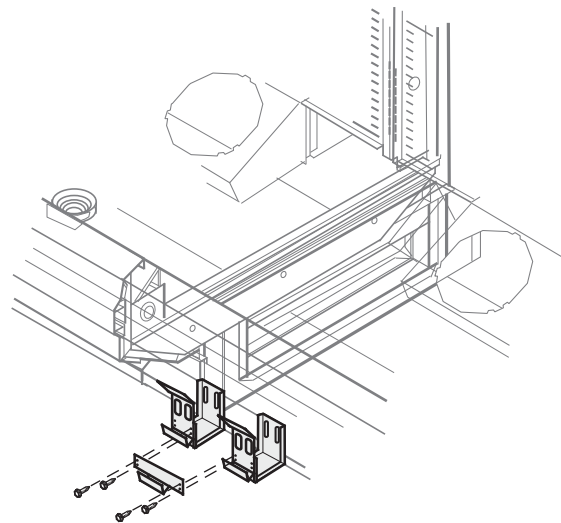

(Splashguard joint support is not used for merchandisers with low fronts.)

Refer to Section 1 of Installation & Operation manual 043880 to install splashguard brackets, splashguards, and bumpers.

