

We reserve the right to change or revise specifications and product design in connection with any feature of our products. Such changes do not entitle the buyer to corresponding changes, improvements, additions or replacements for equipment previously sold or shipped.

Item	Part #	Description	Wiring Item #	Item	Part #	Description	Wiring Item #
FAN ASSEMBLIES				LAMPS AND BALLASTS			
8 Ft & 12 Ft				D.		Ballast, Electronic	(4)
A.		7W Standard Energy Efficient Fan Assembly	(1)	0480130		2 lamps (BA.4481676)	
	0477654	Fan Motor, Evaporator (MO.4410545)		0480131		3 lamps (BA.4481654)	
	0142780	Fan Blade (FB.0142780)		0480132		4 lamps (BA.4481677)	
				E.		Fluorescent Lamp	(5)
						<i>Replace with like fixtures</i>	
THERMOSTATS				LED FIXTURES AND POWER SUPPLY			
B.	0411744	Standard Non-adjustable Defrost Thermostat (CT.0411744)	(2)	F.	0501213	Power Supply (EP.4481861)	(6)
C.		Optional Adjustable Refrigeration Thermostat	(3)	G.		LED Canopy Fixture	(7)
						<i>Replace with like fixtures</i>	
				H.		LED Shelf Fixture	(8)
						<i>Replace with like fixtures</i>	

c

Data sheet-Excel-P2X-E

Note: Revision L: Removed 6 foot data. Other changes marked by bar, underline or circle.

Engineering Plan Views

PHYSICAL DATA	
Merchandiser Drip Pipe (in.)	1 1/4
Merchandiser Liquid Line (in.)	3/8
Merchandiser Suction Line (in.)	7/8

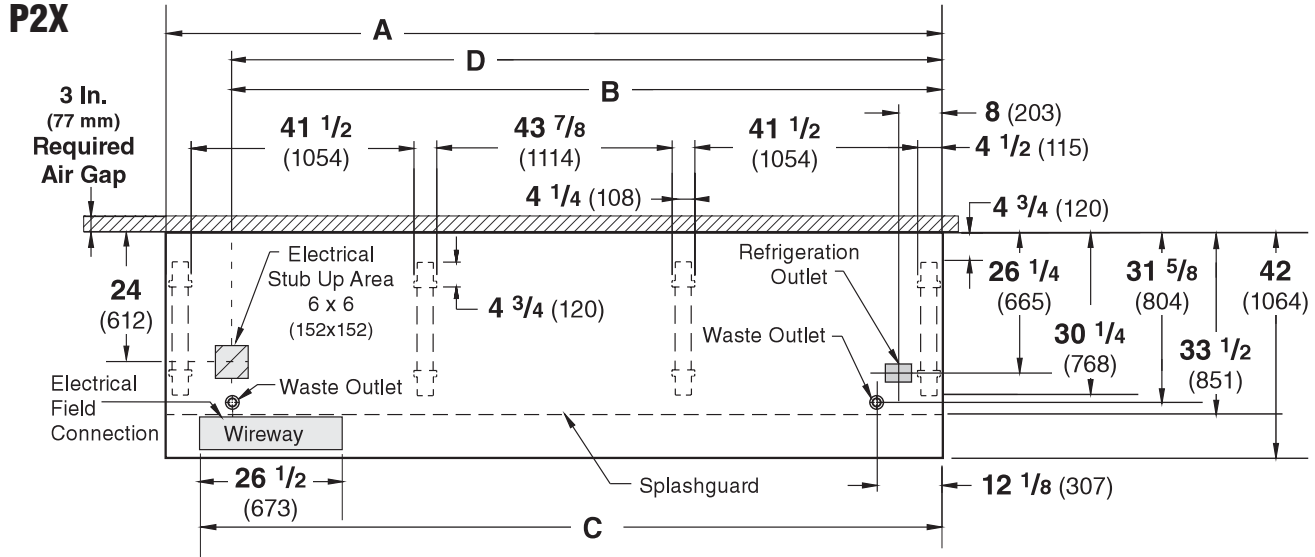

Bulk Produce
10-2004

Dimensions shown as inches and (mm).

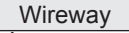

NOTE: Case-to-Case Electrical Connections are made IN FRONT OF SPLASHGUARD.

FRONT

	8 ft	12 ft
General		
(A) Case Length (<i>without ends or partitions</i>) (Each end and insulated partition adds 1 1/2 in. (38 mm) to case line up.) Maximum O/S dimension of case back to front (includes bumper)	96 3/8 (2448)	144 1/2 (3670)
Back of case to front of splashguard	42 (1064)	42 (1064)
Back of case to O/S edge of front leg	33 1/2 (851)	33 1/2 (851)
Distance between edges of external legs and center legs	30 1/4 (768)	30 1/4 (768)
Distance between edges of center legs	41 1/2 (1054)	41 1/2 (1054)
Distance between front legs and splashguard	NA	43 7/8 (1114)
	2 3/4 (70)	2 3/4 (70)
Electrical Service  (<i>Electrical Field Wiring connection point</i>)		
(B) RH End of case to center of stub up area Back of case to center of stub up area Length of electrical wireway 	84 1/4 (2140)	132 3/8 (3363)
	24 (612)	24 (612)
	26 1/2 (673)	26 1/2 (673)
(C) RH End of case to LH end of wireway	90 1/8 (2289)	138 1/4 (3511)
Waste Outlets (<i>One each end</i>) 		
(D) RH End of case to the center of LH waste outlet RH End of case to the center of RH waste outlet Back O/S of case to center of waste outlets Schedule 40 PVC drip pipe	84 1/4 (2140)	132 3/8 (3363)
	12 1/8 (307)	12 1/8 (307)
	31 5/8 (804)	31 5/8 (804)
	1 1/4 (32)	1 1/4 (32)
Refrigeration Outlet 		
Back of case to center of refrigeration outlet	26 1/4 (665)	26 1/4 (665)
RH end of case to center of refrigeration outlet	8 (203)	8 (203)

Multi-deck, 2 Display Levels



Hussmann refrigerated merchandisers configured for sale for use in the United States meet or surpass the requirements of the DOE 2017 energy efficiency standards.

Excel P2X-E
Bulk Produce

REFRIGERATION DATA

Note: This data is based on store temperature and humidity that does not exceed 75°F and 55% R.H.

Dimensions shown as inches and (mm).

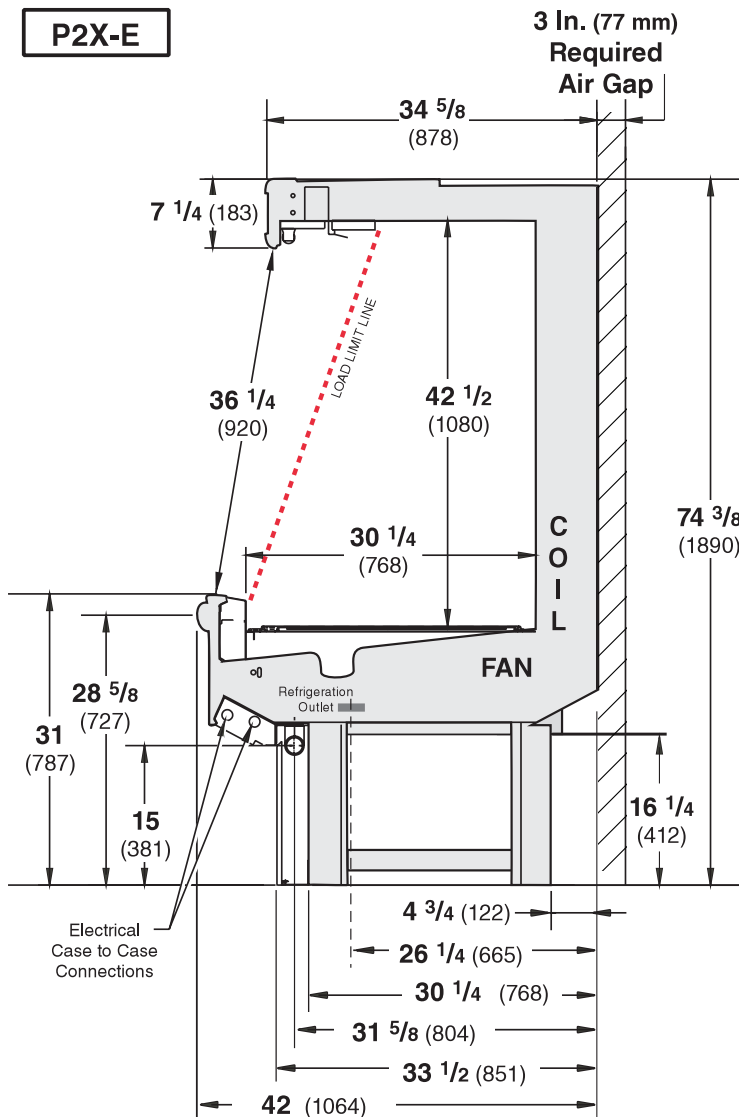

Estimated Charge**		P2X-E	
8 ft	2.3 lb	37 oz	1.0 kg
12 ft	3.3 lb	53 oz	1.5 kg

**This is an average for all refrigerant types. Actual refrigerant charge may vary by approximately half a pound (8 oz/0.2 kg)

NSF Certification

This merchandiser model is manufactured to meet NSF/ANSI (National Sanitation Foundation) Standard #7 requirements for construction, materials & cleanability.

	P2X-E§
Discharge Air °F	33
Evaporator °F	24
Unit Sizing °F	22

§ Average evaporator temperature shown. Use dew point for high glide refrigerants for unit sizing. Care should be taken to use the dew point in PT tables for measuring and adjusting superheat. Adjust evaporator pressure as needed to maintain discharge air temperature shown.

Btu/hr/ft — Unlit Shelves‡		
P2X-E	Parallel	Conventional
UNLIT	949	1029

‡ Add 10 Btu/hr/ft per shelf row for LED fixtures.
Add 20 Btu/hr/ft per shelf row for fluorescent lamps.

DEFROST DATA

	P2X-E
Frequency (hr)	8
Defrost Water (lb/ft/day)	6

(± 15% based on case configuration and product loading).

OFFTIME		P2X-E
Temp Term °F		48°F
Failsafe Minutes		30

ELECTRIC OR GAS Not Recommended

Standard Defrost Thermostat

Close on rise: close 48°F – open 33°F

CONVENTIONAL CONTROLS

Low Pressure Backup Control	P2X-E
CI/CO*	17/7°F

Indoor Unit Only,

Pressure Defrost Termination* 48°F

*Use a Temperature Pressure Chart to determine PSIG conversions.

Electrical Data

			8 ft	12 ft		
Number of Fans — 7W			2	3		
Number of Fans — 4W			—	—		
			Amperes		Watts	
			8 ft	12 ft	8 ft	12 ft
Evaporator Fan						
120V	50/60Hz	Standard Energy Efficient	0.38	0.57	28	42
230V	50/60Hz	Standard Energy Efficient	0.20	0.30	28	42
230V	60Hz	Export	0.50	0.75	78	117
230V	50Hz	Export	0.56	0.84	84	126
Minimum Circuit Ampacity						
120V	50/60Hz	Standard Energy Efficient	0.58	0.77		
230V	60Hz	Export	0.70	0.95		
230V	50Hz	Export	0.76	1.04		
230V	50/60Hz	Standard Energy Efficient	0.40	0.50		
Maximum Over Current Protection 120V			20	20		
Maximum Over Current Protection 230V			15	15		
Standard Lighting (T-8 fluorescent)						
1 Row Canopy			0.51	0.77	59	85
ONLY LIGHTING CONFIGURATIONS THAT ARE COMPLIANT WITH THE U.S. DEPT. OF ENERGY (DOE) 2017 REGULATION ARE AVAILABLE FOR SALE FOR USE IN THE U.S.A.						
Optional Lighting (T-8 fluorescent)						
Additional 1 Row Canopy			0.51	0.77	59	85
Additional 2 Row Canopy			1.02	1.54	118	170
Additional 3 Row Canopy			1.53	2.31	177	255
1 Row Rail Light			0.51	0.77	59	85
1 Row of Shelves			0.51	0.77	59	85
2 Rows of Shelves			1.02	1.54	118	170
3 Rows of Shelves			1.53	2.31	177	255
EcoShine II Canopy						
EcoShine II			0.46	0.70	55.6	83.4
EcoShine II HO			0.56	0.84	67.2	100.8
EcoShine II Rail Light —1 Row			0.17	0.26	20.5	30.7
EcoShine II Shelves						
1 Row of Shelves			0.17	0.26	20.5	30.7
2 Rows of Shelves			0.34	0.51	40.9	61.4
3 Rows of Shelves			0.51	0.77	61.4	92.1

120V Lighting Circuit Total = Standard Lighting + Total Optional Lighting + Optional Shelf Lighting

120V LED Lighting Circuit Total = Canopy Lighting + Shelf Lighting + Optional Rail Lighting

230V Lighting Circuit Total = Multiply 120V Lighting Circuit Total by 0.52

Please note: some combinations of fluorescent lights on this case model may not be compliant with DOE 2017 and may not be available to order in the US and Canada. More lighting options are available with LED lights. The Hussmann Product Configurator will not allow lighting options that do not comply with the DOE 2017 standards.

Product Data

<i>Recommended Usable Cube</i> ¹ (Cu Ft/Ft)	6.69 ft ³ /ft (0.62 m ³ /m)
<i>AHRI Total Display Area</i> ² (Sq Ft/Ft)	3.06 ft ² /ft (0.93 m ² /m)
<i>Shelf Area</i> ³ (Sq Ft/Ft)	3.87 ft ² /ft (1.18 m ² /m)

- ¹ AHRI Refrigerated Volume less shelving and other unusable space: Refrigerated Volume/Unit of Length, ft³/ft [m³/m]
- ² Computed using AHRI 1200 standard methodology: Total Display Area, ft² [m²]/Unit of Length, ft [m]
- ³ Shelf surface area is composed of bottom deck plus standard shelf complement, as shown in the Hussmann *Product Reference Guide*. The standard shelf complement for this model is (1) row of 16-inch shelf.

ESTIMATED SHIPPING WEIGHT ⁴

Case	<i>8 ft</i>	<i>12 ft</i>	Solid End
			<i>(each)</i>
lb (kg)	1000 (454)	1200 (544)	75 (34)

⁴ Actual weights will vary according to optional kits included.

Fan Wiring Offtime Defrost

1, 2 & 3 Fans

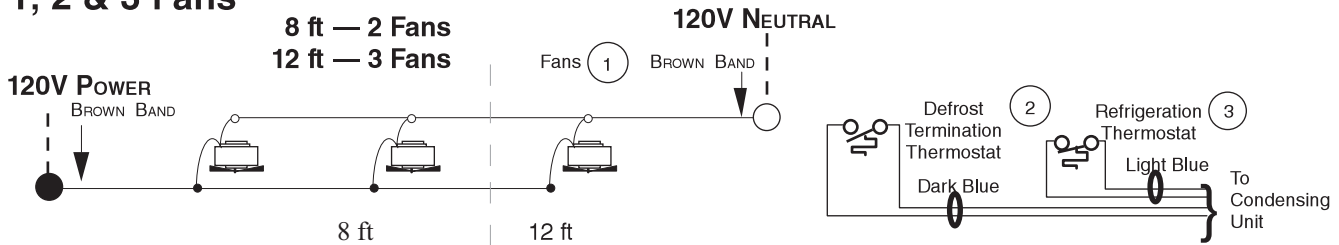

Light Circuits — Fluorescent Fixtures

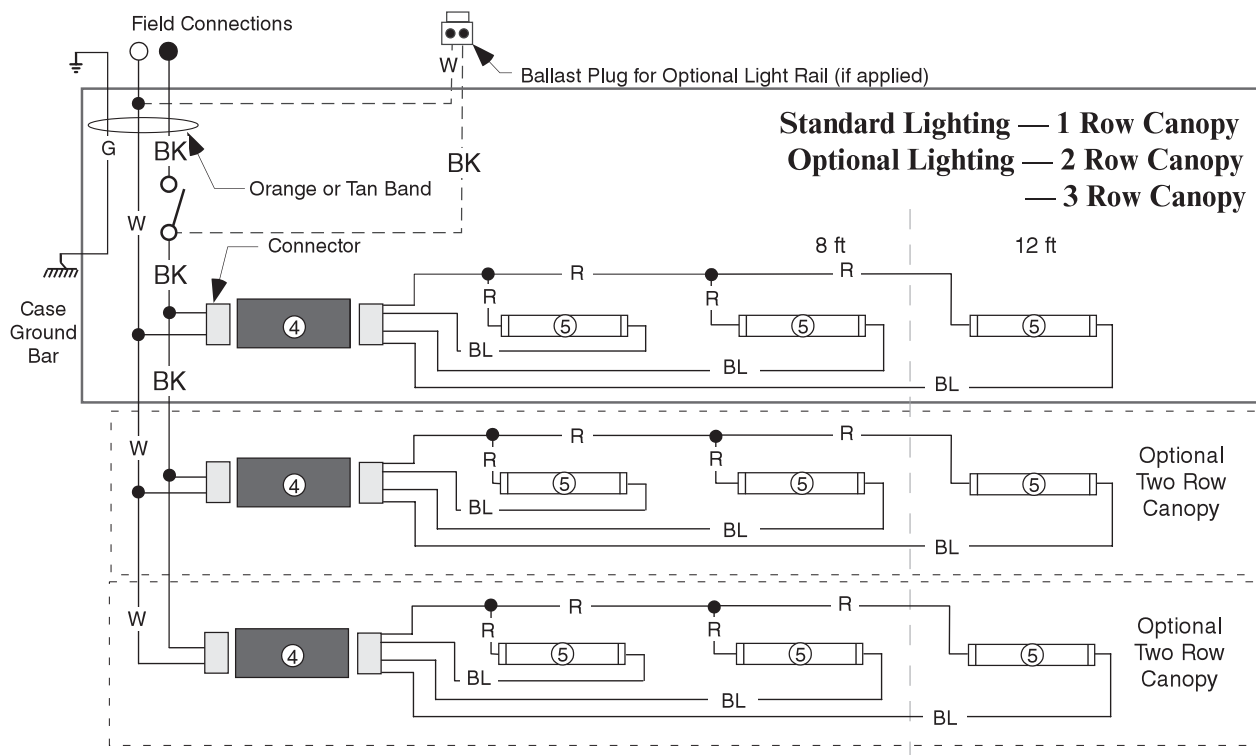

Optional Lighting — 1 Row Rail

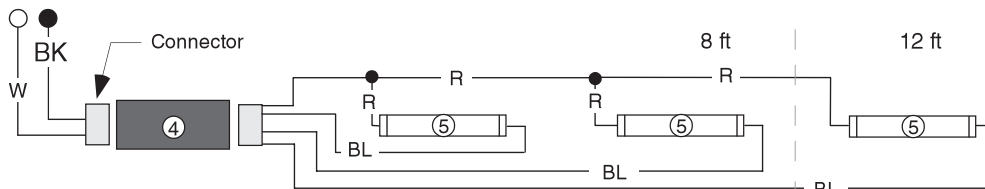

WARNING

All components must have mechanical ground, and the merchandiser must be grounded.

CIRCLED NUMBERS = PARTS LIST ITEM NUMBERS

R = Red Y = Yellow G = Green BL = Blue BK = Black W = White

● = 120V POWER ○ = 120V NEUTRAL ⊥ = FIELD GROUND *mm* = CASE GROUND

Optional Shelf Lighting Fluorescent Fixtures

Optional Shelf Harness and Light Circuits for Two Rows of Shelves

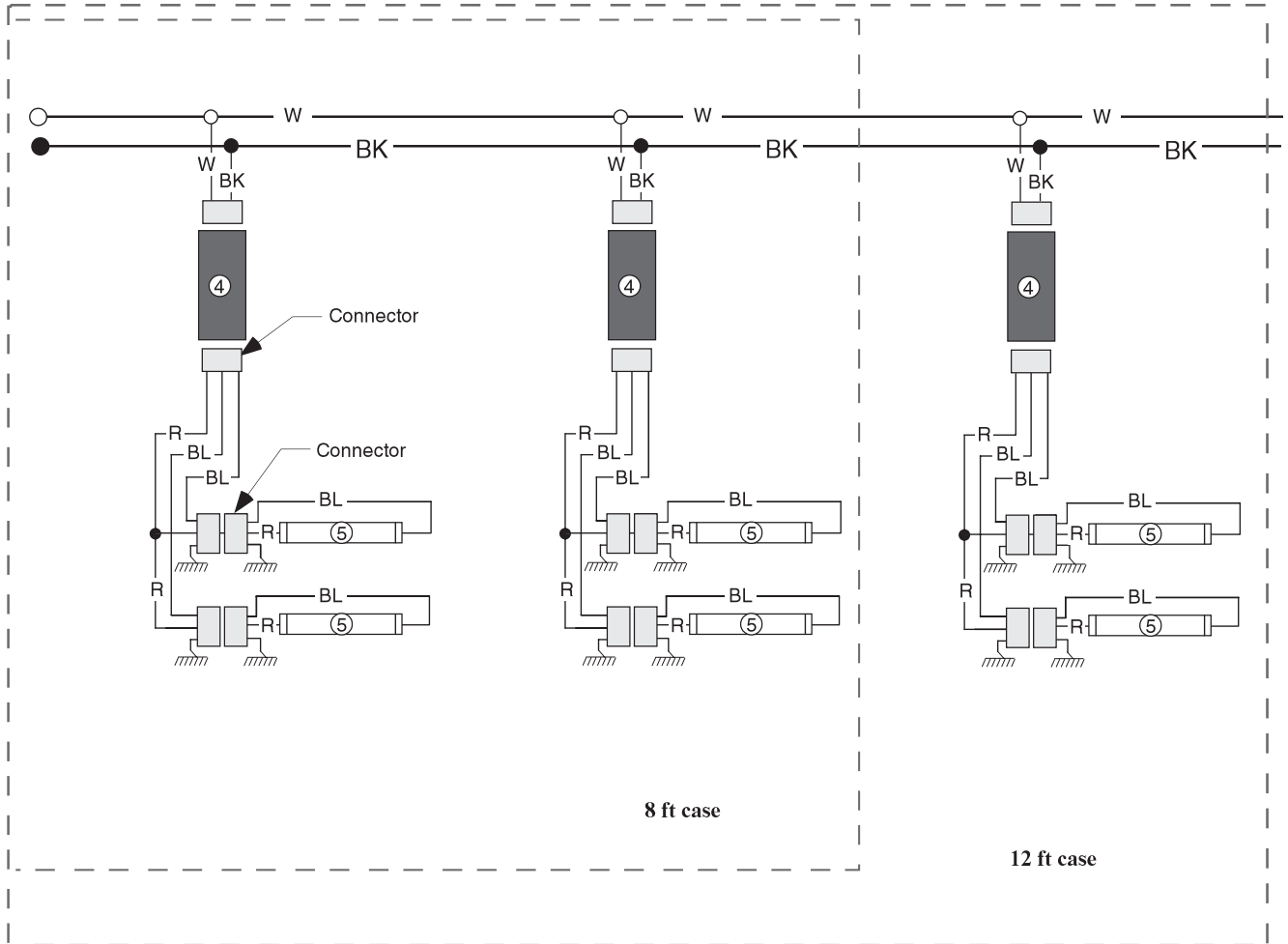

WARNING

All components must have mechanical ground, and the merchandiser must be grounded.

CIRCLED NUMBERS = PARTS LIST ITEM NUMBERS

R = Red Y = Yellow G = Green BL = Blue BK = Black W = White

● = 120V POWER ○ = 120V NEUTRAL ⊥ = FIELD GROUND ≡ = CASE GROUND

Optional Canopy and Rail Light Circuits — LED Fixtures

EcoShine II LED Canopy Lighting — 1 Row

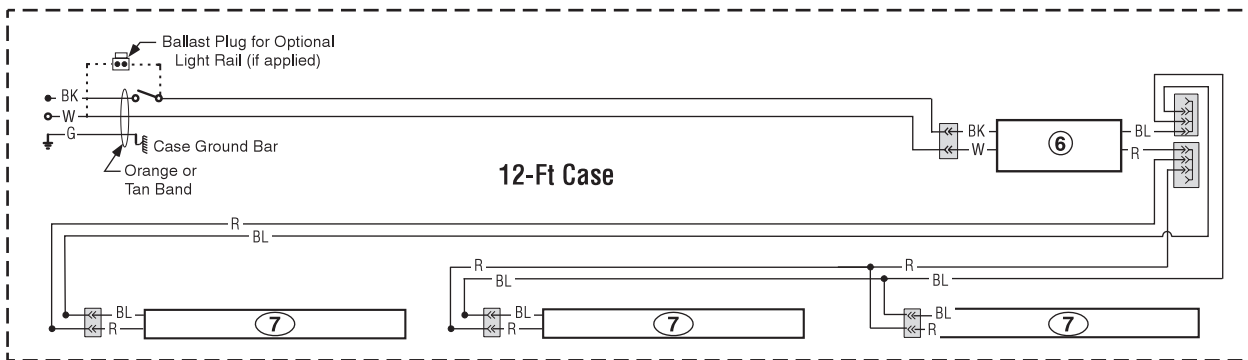
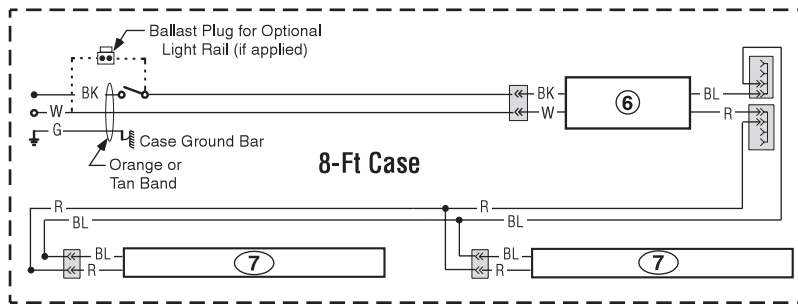

EcoShine II LED Rail Lighting — 1 Row

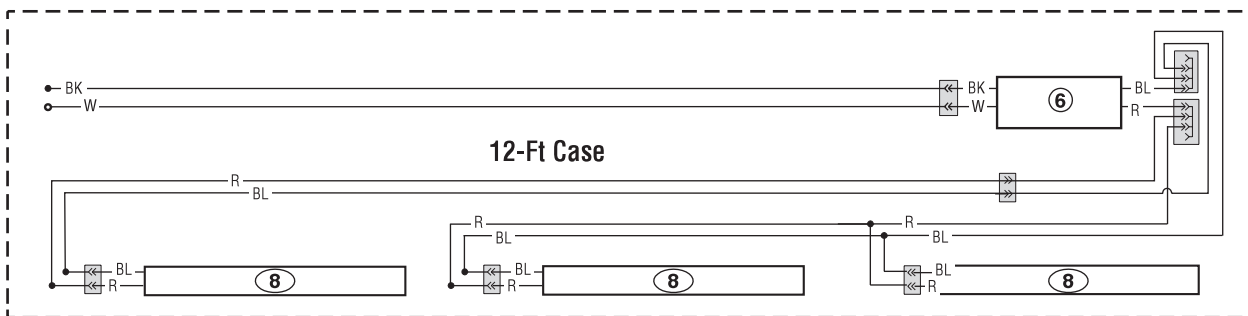
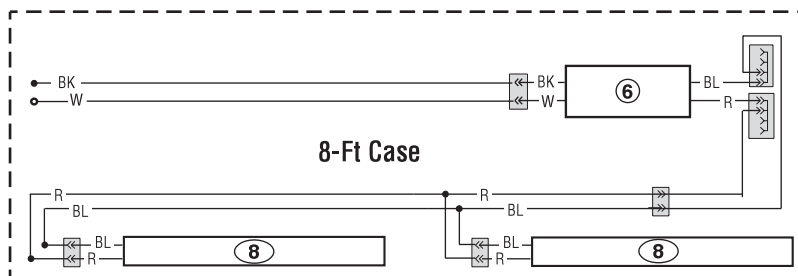

WARNING

All components must have mechanical ground, and the merchandiser must be grounded.

CIRCLED NUMBERS = PARTS LIST ITEM NUMBERS

R = Red Y = Yellow G = Green BL = Blue BK = Black W = White

● = 120V POWER ○ = 120V NEUTRAL ⊥ = FIELD GROUND ≡ = CASE GROUND

Optional Shelf Lighting LED Fixtures

Optional Shelf Harness and LED Light Circuits for 2 or 3 Rows of Shelves

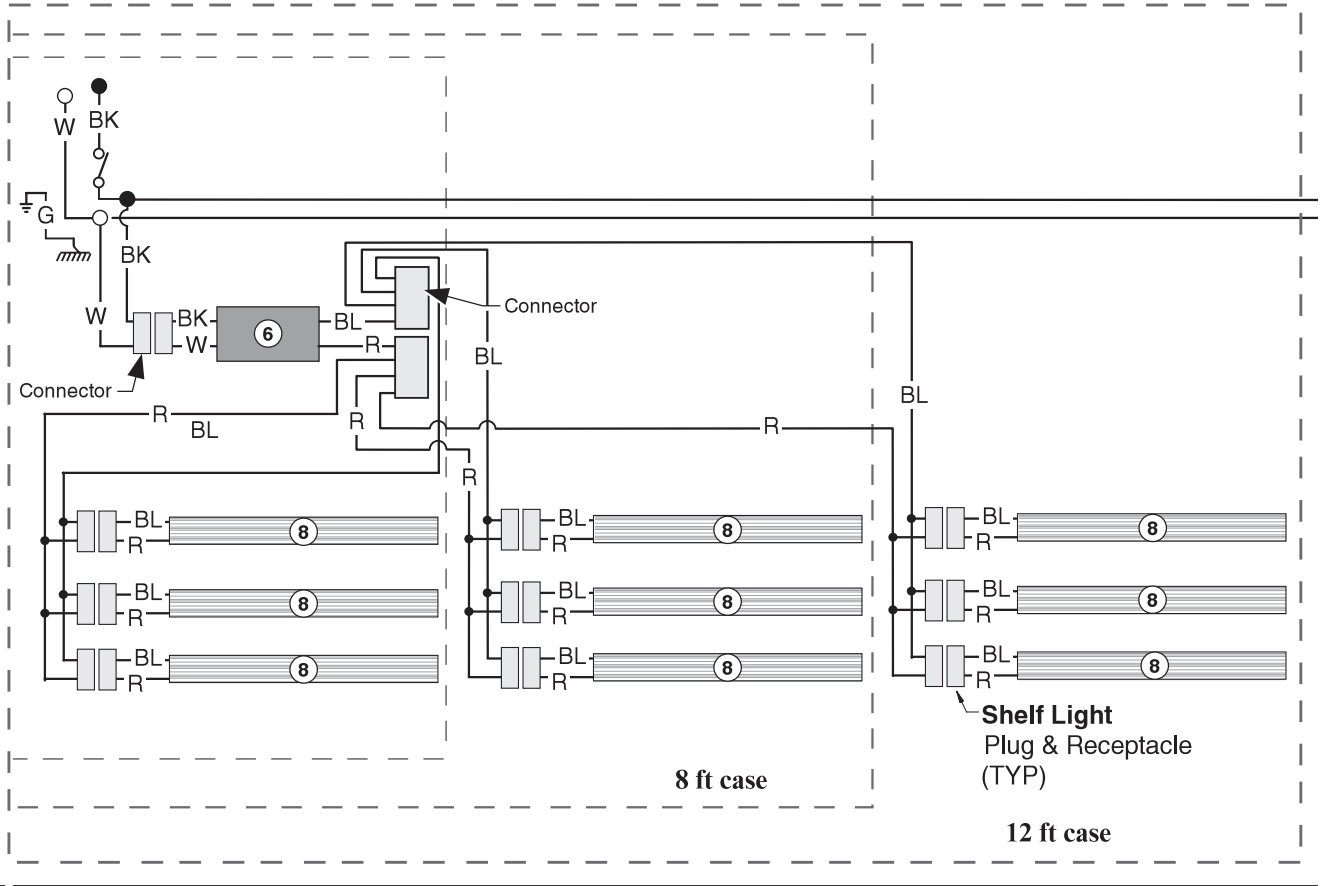

WARNING

All components must have mechanical ground, and the merchandiser must be grounded.

CIRCLED NUMBERS = PARTS LIST ITEM NUMBERS

R = Red G = Green BL = Blue BK = Black W = White
 ● = 80V POWER ○ = 80V NEUTRAL ⚡ = FIELD GROUND mm = CASE GROUND