

We reserve the right to change or revise specifications and product design in connection with any feature of our products. Such changes do not entitle the buyer to corresponding changes, improvements, additions or replacements for equipment previously sold or shipped.

Item	Part #	Description	Wiring Item #	Item	Part #	Description	Wiring Item #
FAN ASSEMBLIES				LAMPS AND BALLASTS			
8 Ft & 12 Ft				C.	Ballast, Electronic		(3)
A.	12W Standard Energy Efficient Fan Assembly (1)			0480130	2 lamps		
	0477655	Fan Motor, Evaporator		0480131	3 lamps		
	0461805	Fan Blade		0480132	4 lamps		
6 Ft Only				D.	Fluorescent Lamp		(4)
A.	7W Standard Energy Efficient Fan Assembly (1)			<i>Replace with like fixtures</i>			
	0477654	Fan Motor, Evaporator		LED FIXTURES AND POWER SUPPLY			
	0142780	Fan Blade		E.	0501213	Power Supply	(5)
THERMOSTATS				F.	LED Canopy Fixture		(6)
B.	Optional Adjustable Refrigeration Thermostat (2)			<i>Replace with like fixtures</i>			
				G.	LED Shelf Fixture		(7)
				<i>Replace with like fixtures</i>			

Data sheet-Excel-M3X-EP

Note: Revision N: April 2017. Updated LED energy values. Other changes marked with a bar, circle or underline.

Engineering Plan Views

PHYSICAL DATA	
Merchandiser Drip Pipe (in.)	1 1/4
Merchandiser Liquid Line (in.)	3/8
Merchandiser Suction Line (in.)	7/8

Meat, Delicatessen & Produce

10-2004

Dimensions shown as in. and (mm).

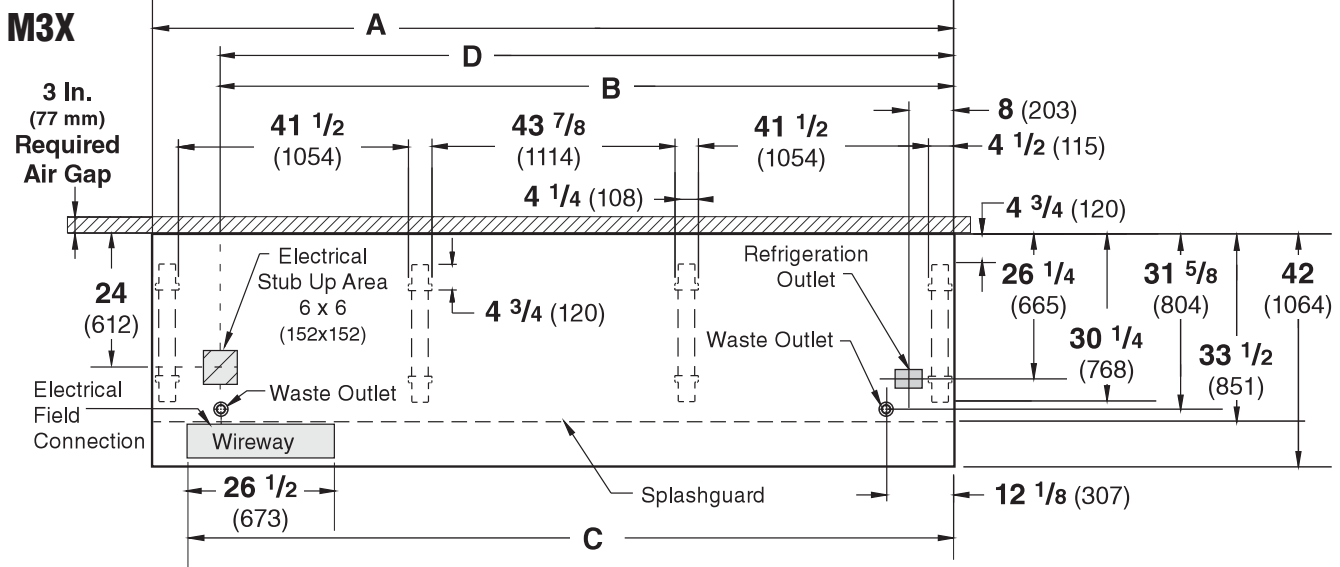

NOTE: Case-to-Case Electrical Connections are made IN FRONT OF SPLASHGUARD. FRONT

	6 ft	8 ft	12 ft
General			
(A) Case Length (<i>without ends or partitions</i>) (Each end and insulated partition adds 1 1/2 in. (38 mm) to case line up.) Maximum O/S dimension of case back to front (includes bumper)	72 3/8 (1838)	96 3/8 (2448)	144 1/2 (3670)
Back of case to front of splashguard	42 (1064)	42 (1064)	42 (1064)
Back of case to O/S edge of front leg	33 1/2 (851)	33 1/2 (851)	33 1/2 (851)
Distance between edges of external legs and center legs	29 1/2 (750)	41 1/2 (1054)	41 1/2 (1054)
Distance between edges of center legs	NA	NA	43 7/8 (1114)
Distance between front legs and splashguard	2 3/4 (70)	2 3/4 (70)	2 3/4 (70)
Electrical Service <input checked="" type="checkbox"/> (<i>Electrical Field Wiring connection point</i>)			
(B) RH End of case to center of stub up area	60 1/4 (1530)	84 1/4 (2140)	132 3/8 (3363)
Back of case to center of stub up area	24 (612)	24 (612)	24 (612)
Length of electrical wireway <input type="checkbox"/> Wireway	26 1/2 (673)	26 1/2 (673)	26 1/2 (673)
(C) RH End of case to LH end of wireway	66 1/8 (1680)	90 1/8 (2289)	138 1/4 (3511)
Waste Outlets (<i>One each end</i>) <input checked="" type="checkbox"/>			
(D) RH End of case to the center of LH waste outlet	60 1/4 (1530)	84 1/4 (2140)	132 3/8 (3363)
RH End of case to the center of RH waste outlet	12 1/8 (307)	12 1/8 (307)	12 1/8 (307)
Back O/S of case to center of waste outlets	31 5/8 (804)	31 5/8 (804)	31 5/8 (804)
Schedule 40 PVC drip pipe	1 1/4 (32)	1 1/4 (32)	1 1/4 (32)
Refrigeration Outlet <input checked="" type="checkbox"/>			
Back of case to center of refrigeration outlet	26 1/4 (665)	26 1/4 (665)	26 1/4 (665)
RH end of case to center of refrigeration outlet	8 (203)	8 (203)	8 (203)

Multi-deck, 3 Display Levels



Hussmann refrigerated merchandisers configured for sale for use in the United States meet or surpass the requirements of the DOE 2017 energy efficiency standards.

Dimensions shown as inches and (mm).

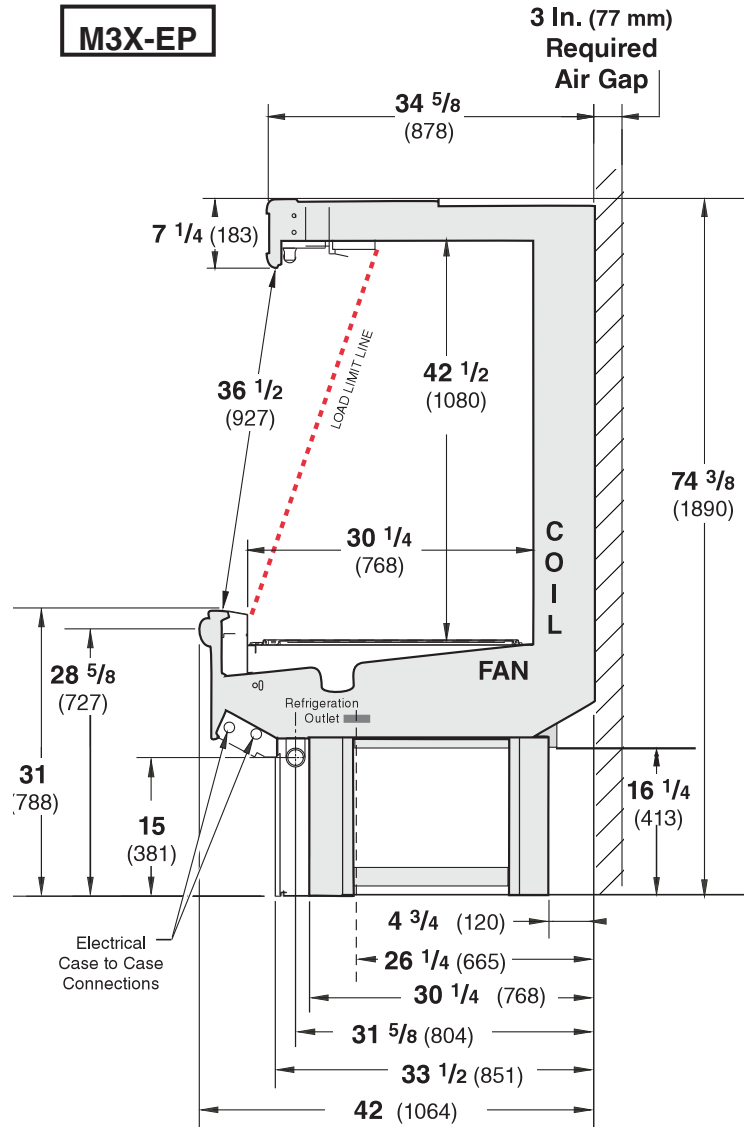

Estimated Charge ****		M3X-EP	
6 ft	2.2 lb	35 oz	1.0 kg
8 ft	3.1 lb	50 oz	1.4 kg
12 ft	4.5 lb	72 oz	2.0 kg

**** This is an average for all refrigerant types. Actual refrigerant charge may vary by approximately half a pound (8 oz/0.2 kg).

NSF Certification

This merchandiser model is manufactured to meet NSF/ANSI (National Sanitation Foundation) Standard #7 requirements for construction, materials & cleanability.

Excel M3X-EP
Meat, Delicatessen
Pre-cut and Packaged Produce

REFRIGERATION DATA

Note: This data is based on store temperature and humidity that does not exceed 75°F and 55% R.H.

M3X-EP [§]	UNLIT	LIT
Discharge Air °F *	31	29
Evaporator °F *	28	26
Unit Sizing °F *	26	24

* See supplemental defrost data sheet, P/N_0530832, for temperature set point on special defrost applications.

§ Average evaporator temperature shown. Use dew point for high glide refrigerants for unit sizing. Care should be taken to use the dew point in PT tables for measuring and adjusting superheat. Adjust evaporator pressure as needed to maintain discharge air temperature shown.

Btu/hr/ft — Unlit Shelves[‡]

M3X-EP	Parallel	Conventional
UNLIT	903	983

[‡] Add 10 Btu/hr/ft per shelf row for LED fixtures.
 Add 20 Btu/hr/ft per shelf row for fluorescent lamps.

DEFROST DATA

Frequency Hr	6
Defrost Water (lb/ft/day)	8

(± 15% based on case configuration and product loading).

OFFTIME	M3X-EP
Time (minutes)	30

ELECTRIC OR GAS ** Not Recommended

** See supplemental defrost data sheet, P/N_0530832, for duration and set point data.

CONVENTIONAL CONTROLS

Low Pressure Backup Control

	M3X-EP
CI/CO ***	19°F / 9°F

Indoor Unit Only,

Pressure Defrost Termination * 48°F**

*** Use a Temperature Pressure Chart to determine PSIG conversions.

Excel M3X-EP Meat, Delicatessen Precut and Packaged Produce
--

Electrical Data

	6 ft	8 ft	12 ft			
Number of Fans—12W	—	2	3			
Number of Fans—7W	2	—	—			
		Amperes			Watts	
	6 ft	8 ft	12 ft	6 ft	8 ft	12 ft
Evaporator Fan						
120V 50/60Hz Standard Energy Efficient	0.38	0.60	0.90	28	36	54
230V 50/60Hz Standard Energy Efficient	0.20	0.30	0.45	28	36	54
230V 60Hz Export	0.50	0.66	0.99	78	100	150
230V 50Hz Export	0.56	0.76	1.14	84	114	171
Minimum Circuit Ampacity						
120V 50/60Hz Standard Energy Efficient	0.58	0.80	1.10			
230V 50/60Hz Standard Energy Efficient	0.40	0.50	0.65			
230V 60Hz Export	0.70	0.86	1.19			
230V 50Hz Export	0.76	0.96	1.34			
Maximum Over Current Protection 120V	20	20	20			
Maximum Over Current Protection 230V	15	15	15			
Standard Lighting (T-8 fluorescent)						
1 Row Canopy	0.51	0.51	0.77	59	59	85
ONLY LIGHTING CONFIGURATIONS THAT ARE COMPLIANT WITH THE U.S. DEPT. OF ENERGY (DOE) 2017 REGULATION ARE AVAILABLE FOR SALE FOR USE IN THE U.S.A.						
Optional Lighting (T-8 fluorescent)						
Additional 1 Row Canopy	0.51	0.51	0.77	59	59	85
Additional 2 Row Canopy	1.02	1.02	1.54	118	118	170
Additional 3 Row Canopy	1.53	1.53	2.31	177	177	255
1 Row Rail Light	0.51	0.51	0.77	59	59	85
2 Rows of Shelves	1.02	1.02	1.54	118	118	170
EcoShine II Canopy						
EcoShine II	0.26	0.32	0.48	31.6	38.6	58.0
EcoShine II HO	0.33	0.44	0.66	39.5	53.0	79.4
EcoShine II Rail Light —1 Row	0.12	0.16	0.25	14.1	19.8	29.7
EcoShine II Shelves						
2 Rows of Shelves	0.23	0.33	0.49	28.2	39.5	59.3

120V Lighting Circuit Total = Standard Lighting + Total Optional Lighting + Optional Shelf Lighting
 120V LED Lighting Circuit Total = Canopy Lighting + Shelf Lighting + Optional Rail Lighting
 230V Lighting Circuit Total = Multiply 120V Lighting Circuit Total by 0.52

Please note: some combinations of fluorescent lights on this case model may not be compliant with DOE 2017 and may not be available to order in the US and Canada. More lighting options are available with LED lights. The Hussmann Product Configurator will not allow lighting options that do not comply with the DOE 2017 standards.

Product Data

<i>Recommended Usable Cube</i> ¹ (Cu Ft/Ft)	6.04 ft ³ /ft (0.56 m ³ /m)
<i>AHRI Total Display Area</i> ² (Sq Ft/Ft)	3.04 ft ² /ft (0.93 m ² /m)
<i>Shelf Area</i> ³ (Sq Ft/Ft)	5.37 ft ² /ft (1.64 m ² /m)

- ¹ AHRI Refrigerated Volume less shelving and other unusable space: Refrigerated Volume/Unit of Length, ft³/ft [m³/m]
- ² Computed using AHRI 1200 standard methodology: Total Display Area, ft² [m²]/Unit of Length, ft [m]
- ³ Shelf surface area is composed of bottom deck plus standard shelf complement, as shown in the Hussmann *Product Reference Guide*. The standard shelf complement for this model is (1) row of 16-inch shelf and (1) row of 18-inch shelf.

ESTIMATED SHIPPING WEIGHT ⁴				
Case	<i>6 ft</i>	<i>8 ft</i>	<i>12 ft</i>	Solid End
				<i>(each)</i>
lb (kg)	800 (363)	1000 (454)	1300 (590)	75 (34)
⁴ Actual weights will vary according to optional kits included.				

Fan Wiring Offtime Defrost

2 & 3 Fans

6 ft — 2 Fans
8 ft — 2 Fans
12 ft — 3 Fans

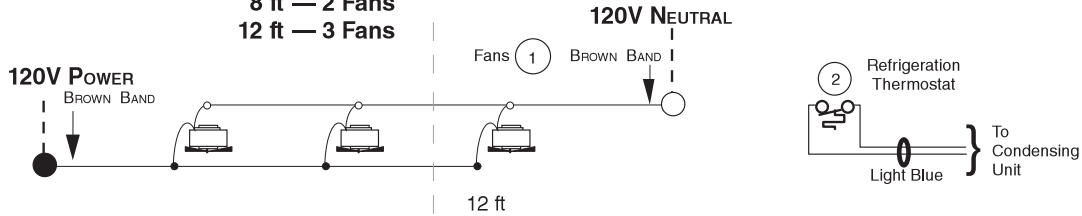

Light Circuits — Fluorescent Fixtures

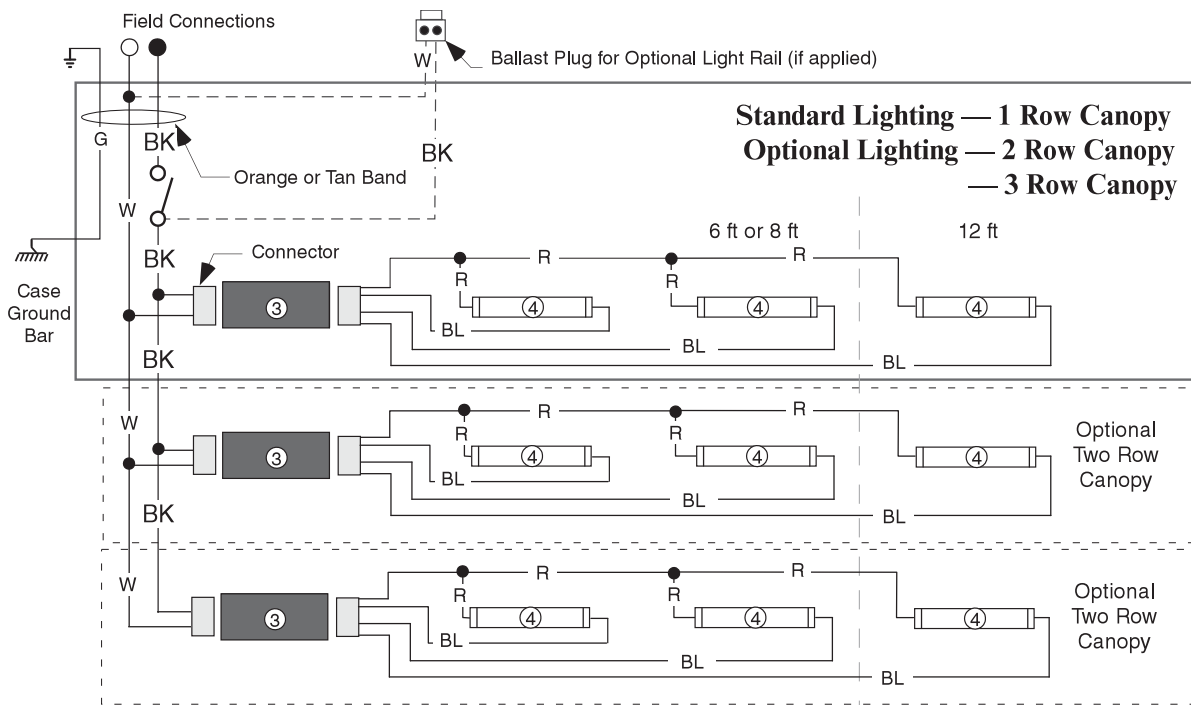

Optional Lighting — 1 Row Rail

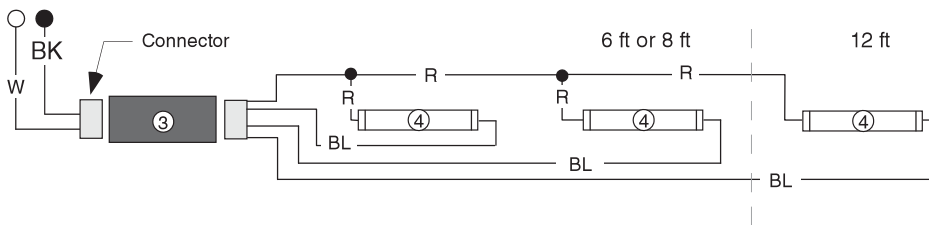

WARNING

All components must have mechanical ground, and the merchandiser must be grounded.

CIRCLED NUMBERS = PARTS LIST ITEM NUMBERS

R = Red Y = Yellow G = Green BL = Blue BK = Black W = White

● = 120V POWER ○ = 120V NEUTRAL ⊥ = FIELD GROUND ≡ = CASE GROUND

Optional Shelf Lighting Fluorescent Fixtures

Optional Shelf Harness and Light Circuits for Two Rows of Shelves

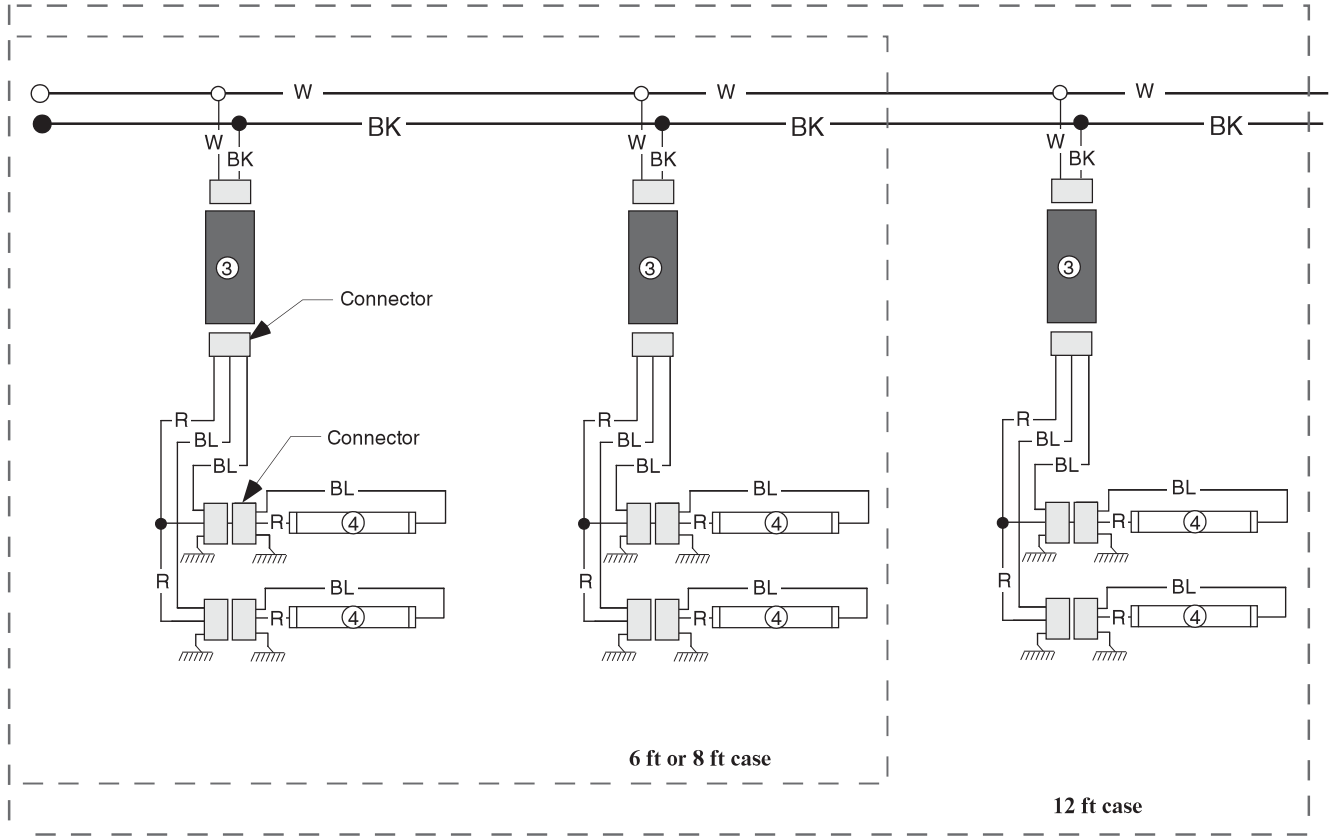

WARNING

All components must have mechanical ground, and the merchandiser must be grounded.

CIRCLED NUMBERS = PARTS LIST ITEM NUMBERS

R = Red Y = Yellow G = Green BL = Blue BK = Black W = White

● = 120V POWER ○ = 120V NEUTRAL ⊥ = FIELD GROUND ≡ = CASE GROUND

Optional Canopy and Rail Light Circuits — LED Fixtures

EcoShine II LED Canopy Lighting — 1 Row

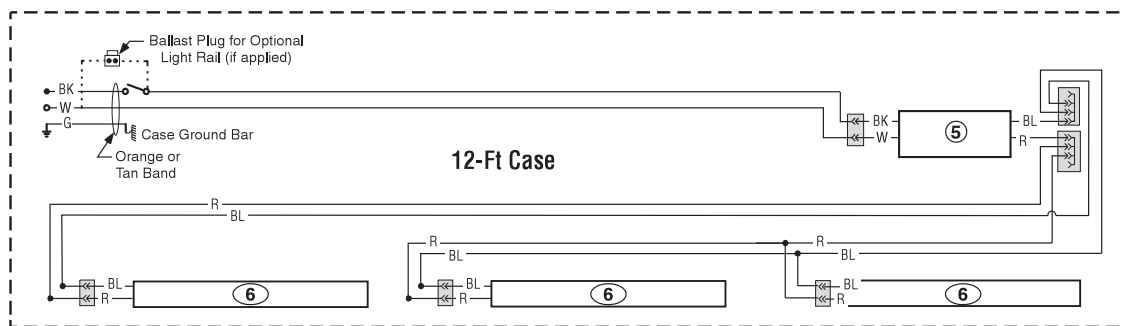
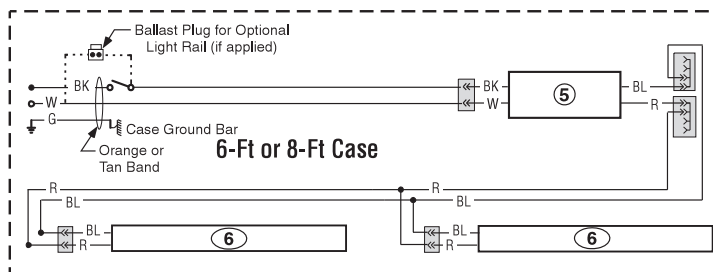

EcoShine II LED Rail Lighting — 1 Row

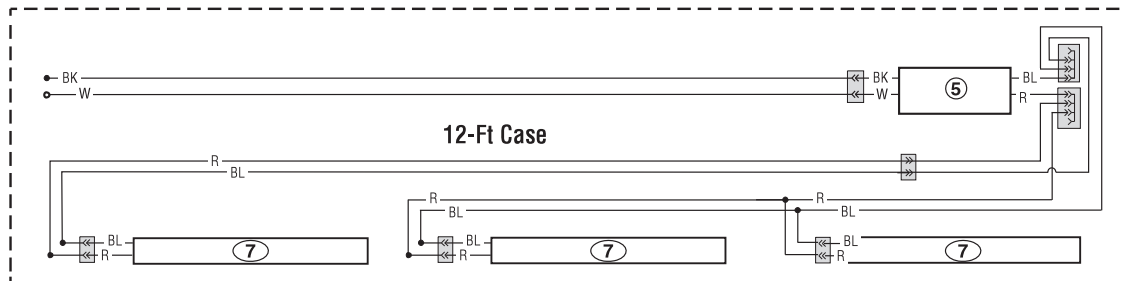
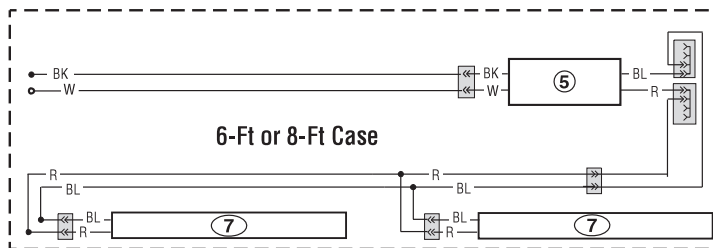

WARNING

All components must have mechanical ground, and the merchandiser must be grounded.

CIRCLED NUMBERS = PARTS LIST ITEM NUMBERS

R = Red Y = Yellow G = Green BL = Blue BK = Black W = White

● = 120V POWER ○ = 120V NEUTRAL ⊥ = FIELD GROUND ⏏ = CASE GROUND

Optional Shelf Lighting LED Fixtures

Optional Shelf Harness and LED Light Circuits for 2 or 3 Rows of Shelves

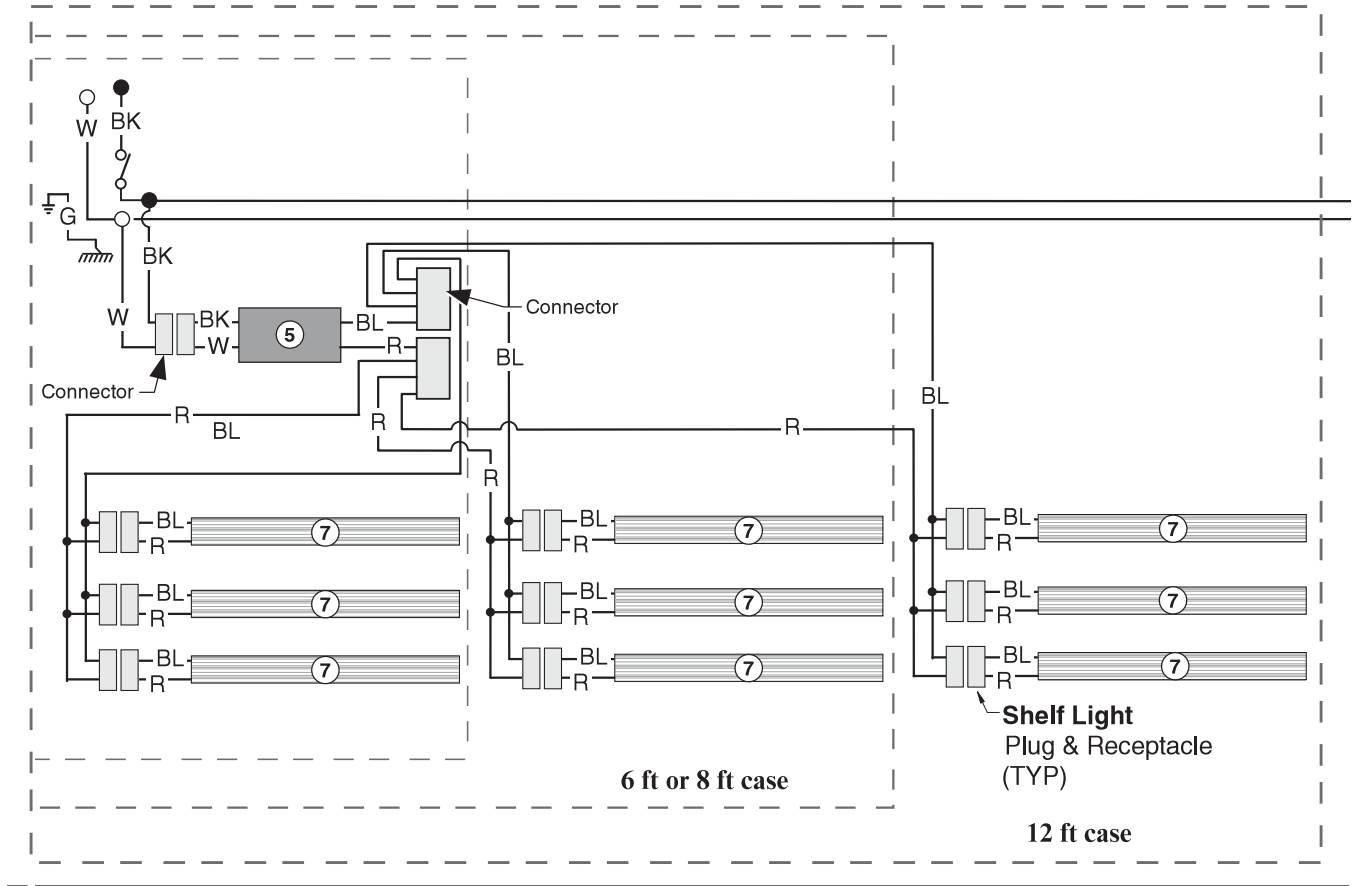

WARNING

All components must have mechanical ground, and the merchandiser must be grounded.

CIRCLED NUMBERS = PARTS LIST ITEM NUMBERS

R = Red G = Green BL = Blue BK = Black W = White

● = 120V POWER ○ = 120V NEUTRAL ⚡ = FIELD GROUND *mm* = CASE GROUND