

We reserve the right to change or revise specifications and product design in connection with any feature of our products. Such changes do not entitle the buyer to corresponding changes, improvements, additions or replacements for equipment previously sold or shipped.

Item	Part #	Description	Wiring Item #	Item	Part #	Description	Wiring Item #
FAN ASSEMBLIES, AND THERMOSTATS				HEATERS			
A.	4W Standard Fan Assembly		(1)	E.	208V Evaporator Defrost Heaters		(5)
	0392457	Fan Motor, Evaporator (MO.4410101)			0462159	8 ft case (HE.4850603)	
	0464847	Fan Blade (FB.4780649)			0444058	12 ft case (HE.4850571)	
	4W Energy Efficient Fan Assembly		(1)	F.	208V Drip Pan Defrost Heaters, Electric		(6)
	0477653	Fan Motor, Evaporator (MO.4410544)			0462160	8 ft case (HE.4850636)	
	0464847	Fan Blade (FB.4780649)			0444296	12 ft case (HE.4850572)	
B.	Optional Adjustable Refrigeration Thermostat		(2)		120V Drip Pan Defrost Heaters, Koolgas		(7)
					0465907	8 ft case (HE.4850622)	
					0465908	12 ft case (HE.4850623)	
C.	0398557	Defrost Termination Thermostat (Electric Defrost only) (CT.4440611)	(3)	G.	Nosing Anti-sweat Heaters		(8)
					0495007	8 ft case (HE.4850685)	
					0495008	12 ft case (HE.4850686)	
D.	0481370	Heater Switch (Koolgas Defrost only) (CT.4440738)	(4)				

Note: Revision D adds energy efficient fan Btu note and updates page 3. Changes are underlined, circled or marked with a vertical line in the margin.



Engineering Plan Views

PHYSICAL DATA

Merchandiser Drip Pipe (in.)	1 1/4
Merchandiser Liquid Line (in.)	3/8
Merchandiser Suction Line (in.)	5/8

Low / Medium Temperature

Dimensions shown as inches and (mm).

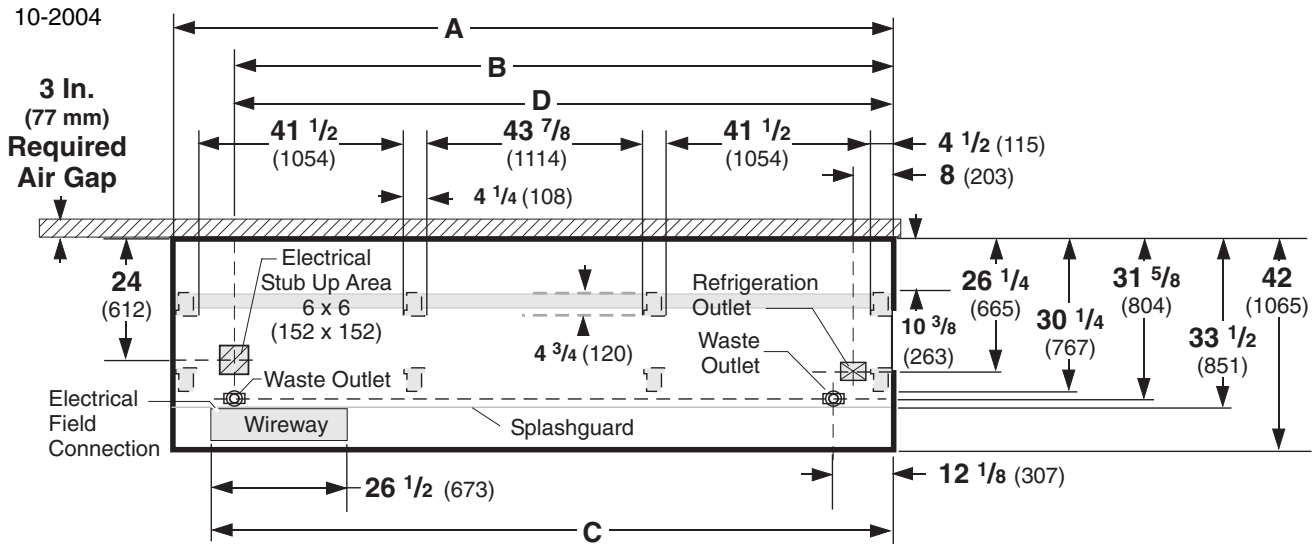

NOTE: Case-to-Case Electrical Connections are made IN FRONT OF SPLASHGUARD.

FRONT

	8 ft	12 ft
General		
(A) Case Length (<i>without ends or partitions</i>) (Each end and insulated partition adds 2 in. (51 mm) to case line up.) Maximum O/S dimension of case back to front (<i>includes bumper</i>) Back of case to front of splashguard Back of case to O/S edge of front leg Distance between edges of external legs and center legs Distance between edges of center legs Distance between front legs and splashguard	96 3/8 (2448) 42 (1065) 33 1/2 (851) 30 1/4 (767) 41 1/2 (1054) NA 3 1/8 (82)	144 1/2 (3670) 42 (1065) 33 1/2 (851) 30 1/4 (767) 41 1/2 (1054) 43 7/8 (1114) 3 1/8 (82)
Electrical Service (<i>Electrical Field Wiring connection point</i>)		
(B) RH End of case to center of stub up area Back of case to center of stub up area Length of electrical wireway	84 1/4 (2140) 24 (612) 26 1/2 (673)	132 3/8 (3363) 24 (612) 26 1/2 (673)
(C) RH End of case to LH end of wireway	90 1/8 (2289)	138 1/4 (3511)
Waste Outlets (<i>One each end</i>)		
(D) RH End of case to the center of LH waste outlet RH End of case to the center of RH waste outlet Back O/S of case to center of waste outlets Schedule 40 PVC drip pipe	84 1/4 (2141) 12 1/8 (307) 31 5/8 (804) 1 1/4 (32)	132 3/8 (3363) 12 1/8 (307) 31 5/8 (804) 1 1/4 (32)
Refrigeration Outlet		
Back of case to center of refrigeration outlet RH end of case to center of refrigeration outlet	26 1/4 (665) 8 (203)	26 1/4 (665) 8 (203)

Excel F
Low / Medium Temperature

REFRIGERATION DATA

Note: This data is based on store temperature and humidity that does not exceed 75°F and 55% R.H.

	MED	FF	IC
Discharge Air (°F)	+24	-12	-22
Evaporator (°F)	+19	-20	-30
Unit Sizing (°F)	+17	-23	-33
Btu/hr/ft³	MED	FF	IC
Parallel	270	375	385
Conventional	280	390	400

[‡]Optional energy efficient motors reduce the refrigeration load by 9 Btu/hr/ft.

DEFROST DATA

	MED	FF	IC
Frequency (hr)	24	24	24
Defrost Water (lb/ft/day)	0.6	0.75	0.8

(± 15% based on case configuration and product loading).

ELECTRIC	MED	FF	IC
Temp Term (°F)	48	48	48
Failsafe (minutes)	60	60	60

GAS	MED	FF	IC
Duration (minutes)	NA	15	18

OFFTIME Not Recommended

Standard Defrost Thermostat

Close on rise: close 48°F — open 33°F

CONVENTIONAL CONTROLS

Low Pressure Backup Control — CI/CO *

MED	+12°F / +2°F
FF	-17°F / -29°F
IC	-27°F / -39°F

Indoor Unit Only, Pressure Defrost Termination*

Not Recommended

*Use a Temperature Pressure Chart to determine PSIG conversions.

Estimated Charge **

8 ft	2.0 lb	32 oz	0.9 kg
12 ft	3.0 lb	48 oz	1.4 kg

**This is an average for all refrigerant types. Actual refrigerant charge may vary by approximately 0.5 lb (8 oz / 0.2 kg).

F

Dimensions shown as inches and (mm).

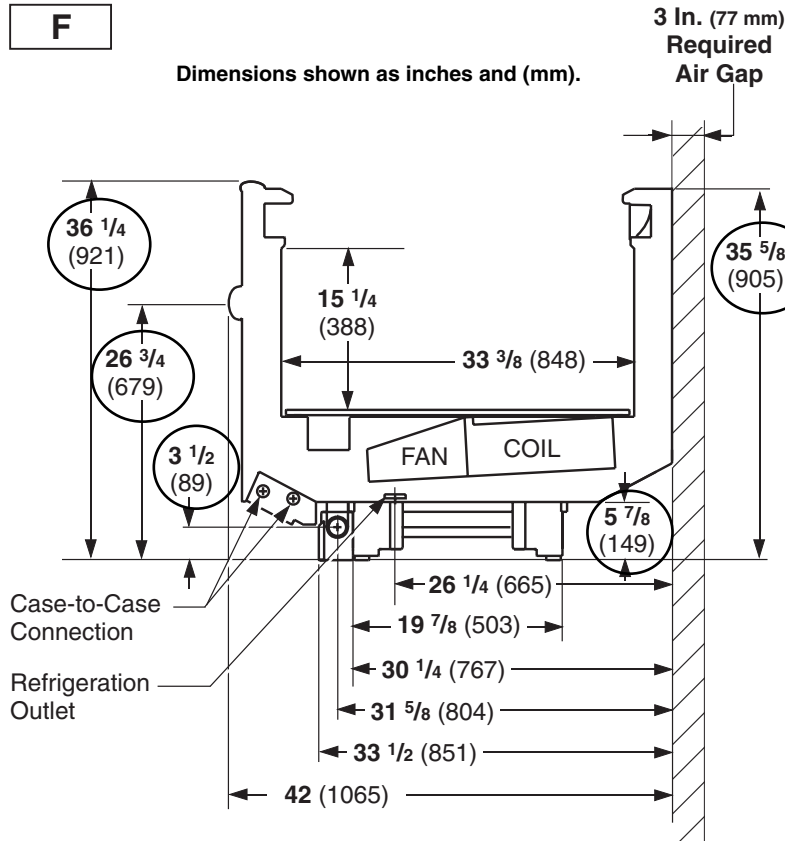

NSF Certification

This merchandiser model is manufactured to meet ANSI/NSF (National Sanitation Foundation) Standard #7 requirements for construction, materials & cleanability.

Electrical Data

			8 ft	12 ft		
Number of Fans – 4W Evaporator			2	2		
			Amperes		Watts	
			8 ft	12 ft	8 ft	12 ft
Evaporator Fans						
120V	60Hz	Standard	0.62	0.62	48	48
120V	50Hz	Standard	0.76	0.76	54	54
230V	60Hz	Export	0.30	0.30	48	48
230V	50Hz	Export	0.36	0.36	54	54
120V	60Hz	Energy Efficient	0.24	0.24	16	16
230V	60Hz	Energy Efficient	0.12	0.12	16	16
Anti-sweat Heaters (on fan circuit)						
120V	50/60Hz	Standard	0.67	1.00	80	120
230V	50/60Hz	Export	0.35	0.52	80	120
Minimum Circuit Ampacity						
120V	60Hz	Standard	1.49	1.82		
120V	50Hz	Standard	1.63	1.96		
230V	60Hz	Export	0.85	1.02		
230V	50Hz	Export	0.91	1.08		
120V	60Hz	Energy Efficient	1.11	1.44		
230V	60Hz	Energy Efficient	0.67	0.84		
Maximum Over Current Protection 120V			20	20		
Maximum Over Current Protection 230V			15	15		
208V Electric Defrost			7.69	11.54	1600	2400
230V Export Electric Defrost			6.96	10.43	1600	2400
120V Koolgas Defrost			1.67	3.33	200	400
Standard Lighting						
None						

Product Data

<i>Recommended Usable Cube</i> ¹ (Cu Ft/Ft)	3.55 ft ³ /ft (0.33 m ³ /m)
<i>AHRI Total Display Area</i> ² (Sq Ft/Ft)	2.78 ft ² /ft (0.85 m ² /m)
<i>Shelf Area</i> ³ (Sq Ft/Ft)	2.79 ft ² /ft (0.85 m ² /m)

¹ AHRI Refrigerated Volume less shelving and other unusable space: Refrigerated Volume/Unit of Length, ft³/ft [m³/m]
² Computed using AHRI 1200 standard methodology: Total Display Area, ft² [m²]/Unit of Length, ft [m]
³ Shelf surface area is composed of bottom deck plus standard shelf complement, as shown in the Hussmann *Product Reference Guide*. The standard shelf complement for this model is NONE.

ESTIMATED SHIPPING WEIGHT ⁴					
Case	<i>4 ft</i>	<i>6 ft</i>	<i>8 ft</i>	<i>12 ft</i>	Solid End
					<i>(each)</i>
1b (kg)	NA (NA)	NA (NA)	1000 (454)	1200 (544)	50 (23)
⁴ Actual weights will vary according to optional kits included.					

Electric Defrost – Standard

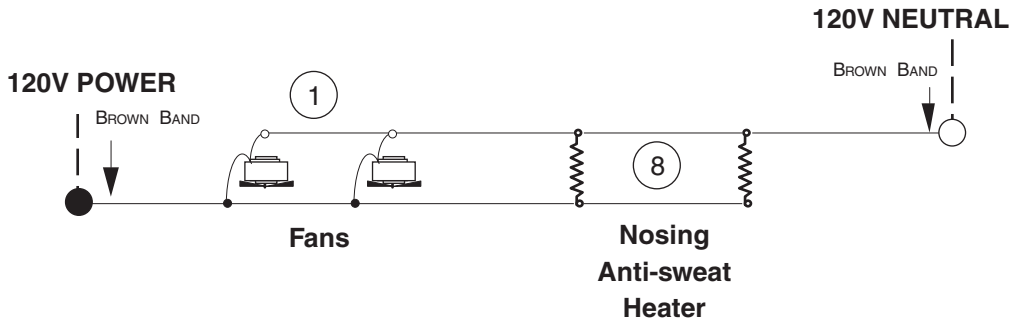

Refrigeration Thermostat (Optional)

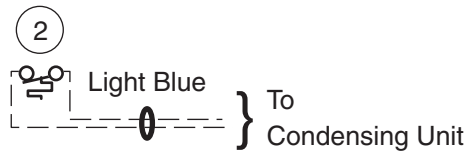

Defrost Termination Thermostat

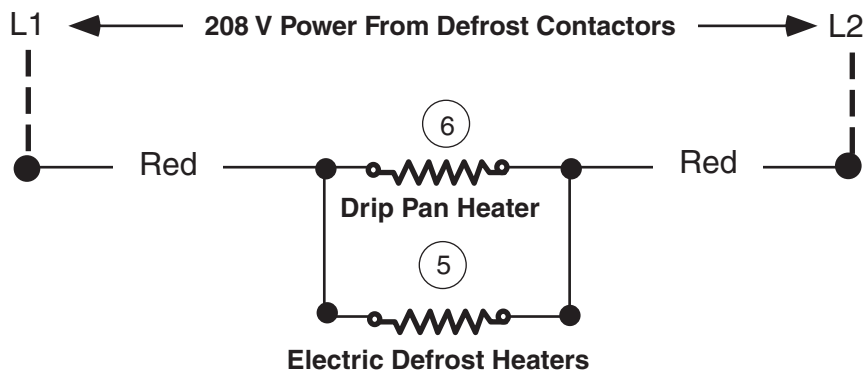
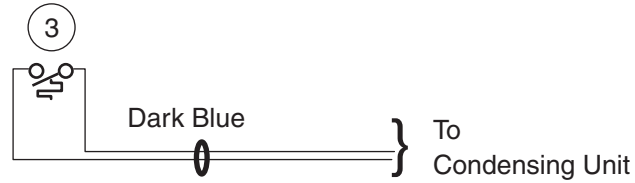

WARNING

All components must have mechanical ground, and the merchandiser must be grounded.
 Circled Numbers = Parts List Item Numbers.

Gas Defrost – Optional

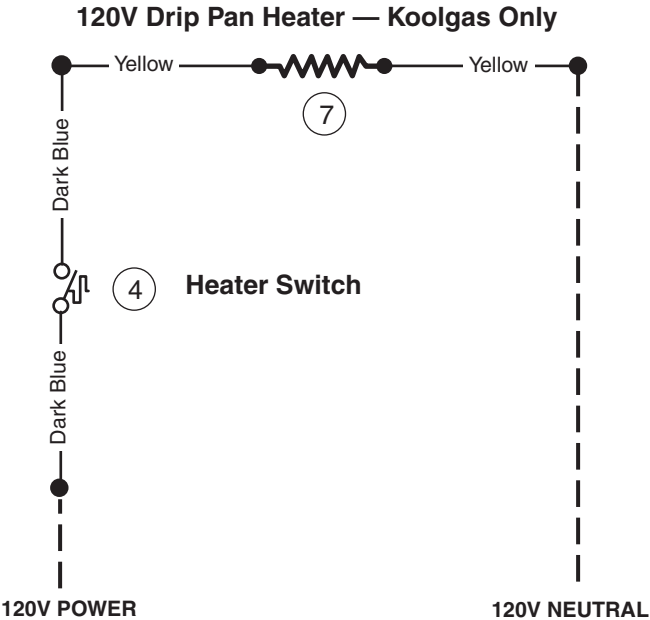

WARNING

All components must have mechanical ground, and the merchandiser must be grounded.
Circled Numbers = Parts List Item Numbers.