

We reserve the right to change or revise specifications and product design in connection with any feature of our products. Such changes do not entitle the buyer to corresponding changes, improvements, additions or replacements for equipment previously sold or shipped.

Item	Part #	Description	Wiring Item #	Item	Part #	Description	Wiring Item #
FAN ASSEMBLIES				HEATERS			
4 Ft, 8 Ft & 12 Ft				C.		Canopy Anti-Sweat Heater	(3)
A.	7W Standard	Fan Assembly	(1)	0512499		4 ft (HE.4851174)	
	0058698	Fan Motor, Evaporator (MO.4410102)		0512500		6 ft (HE.4851175)	
	0142780	Fan Blade (FB.0142780)		0512501		8 ft (HE.4851176)	
	7W Energy Efficient	Fan Assembly	(1)	0512503		12 ft (HE.4851178)	
	0477654	Fan Motor, Evaporator (MO.4410545)		LAMPS AND BALLASTS			
	0142780	Fan Blade (FB.0142780)		D.		Ballast, Electronic	(4)
6 Ft Only				0480130		2 lamps (BA.4481676)	
A.	4W Standard	Fan Assembly	(1)	0480131		3 lamps (BA.4481654)	
	0392457	Fan Motor, Evaporator (MO.4410101)		0480132		4 lamps (BA.4481677)	
	0382383	Fan Blade (FB.4780617)		E.		Fluorescent Lamp	(5)
	4W Energy Efficient	Fan Assembly	(1)			<i>Replace with like fixtures</i>	
	0477653	Fan Motor, Evaporator (MO.4410544)		LED FIXTURES AND POWER SUPPLY			
	0382383	Fan Blade (FB.4780617)		F.	0501213	Power Supply (EP.4481861)	(6)
THERMOSTATS				G.		LED Canopy Fixture	(7)
B.	Optional Adjustable Refrigeration Thermostat		(2)			<i>Replace with like fixtures — See Page 5.</i>	
				H.		LED Shelf Fixture	(8)
						<i>Replace with like fixtures — See Page 5.</i>	

Note: Revision K adds 4-ft length.



Engineering Plan Views

PHYSICAL DATA

Merchandiser Drip Pipe (in.)	1 1/4
Merchandiser Liquid Line (in.)	3/8
Merchandiser Suction Line (in.)	7/8

Dairy/Delicatessen Precut & Packaged Produce

05-2006

Dimensions shown as inches and (mm).

C2X

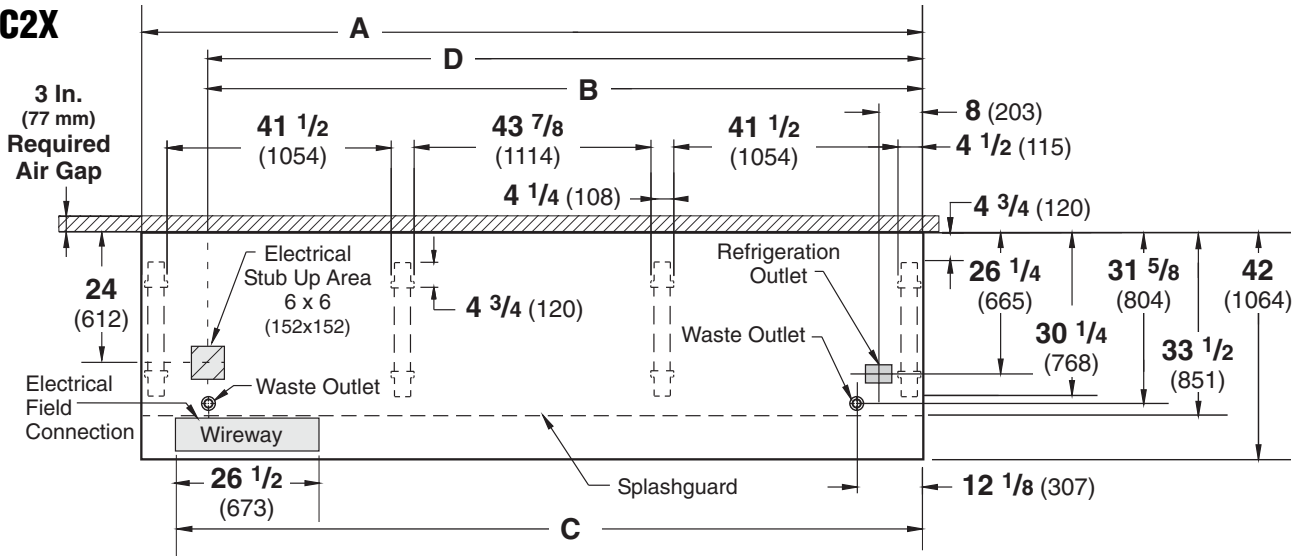

**NOTE: Case-to-Case Electrical Connections
are made IN FRONT OF SPLASHGUARD.**

FRONT

	4 ft	6 ft	8 ft	12 ft
General				
(A) Case Length (<i>without ends or partitions</i>)	48 3/8 (1229)	72 3/8 (1838)	96 3/8 (2448)	144 1/2 (3670)
<i>(Each end and insulated partition adds 1 1/2 in. (38 mm) to case line up.)</i>				
Maximum O/S dimension of case back to front <i>(includes bumper)</i>	42 (1064)	42 (1064)	42 (1064)	42 (1064)
Back of case to front of splashguard	33 1/2 (851)	33 1/2 (851)	33 1/2 (851)	33 1/2 (851)
Back of case to O/S edge of front leg	30 1/4 (768)	30 1/4 (768)	30 1/4 (768)	30 1/4 (768)
Distance between edges of external legs and center legs	NA	29 1/2 (750)	41 1/2 (1054)	41 1/2 (1054)
Distance between edges of center legs	NA	NA	NA	43 7/8 (1114)
Distance between front legs and splashguard	2 3/4 (70)	2 3/4 (70)	2 3/4 (70)	2 3/4 (70)
Electrical Service (<i>Electrical Field Wiring connection point</i>)				
(B) RH End of case to center of stub up area	36 1/4 (921)	60 1/4 (1530)	84 1/4 (2140)	132 3/8 (3363)
Back of case to center of stub up area	24 (612)	24 (612)	24 (612)	24 (612)
Length of electrical wireway	26 1/2 (673)	26 1/2 (673)	26 1/2 (673)	26 1/2 (673)
(C) RH End of case to LH end of wireway	42 1/8 (1070)	66 1/8 (1680)	90 1/8 (2289)	138 1/4 (3511)
Waste Outlets (<i>One each end</i>)				
(D) RH End of case to the center of LH waste outlet	36 1/4 (921)	60 1/4 (1530)	84 1/4 (2140)	132 3/8 (3363)
RH End of case to the center of RH waste outlet	12 1/8 (307)	12 1/8 (307)	12 1/8 (307)	12 1/8 (307)
Back O/S of case to center of waste outlets	31 5/8 (804)	31 5/8 (804)	31 5/8 (804)	31 5/8 (804)
Schedule 40 PVC drip pipe	1 1/4 (32)	1 1/4 (32)	1 1/4 (32)	1 1/4 (32)
Refrigeration Outlet				
Back of case to center of refrigeration outlet	26 1/4 (665)	26 1/4 (665)	26 1/4 (665)	26 1/4 (665)
RH end of case to center of refrigeration outlet	8 (203)	8 (203)	8 (203)	8 (203)

Impact Excel C2X-LEP
Dairy/Delicatessen
Precut & Packaged Produce

Dimensions shown as inches and (mm).

C2X-LEP

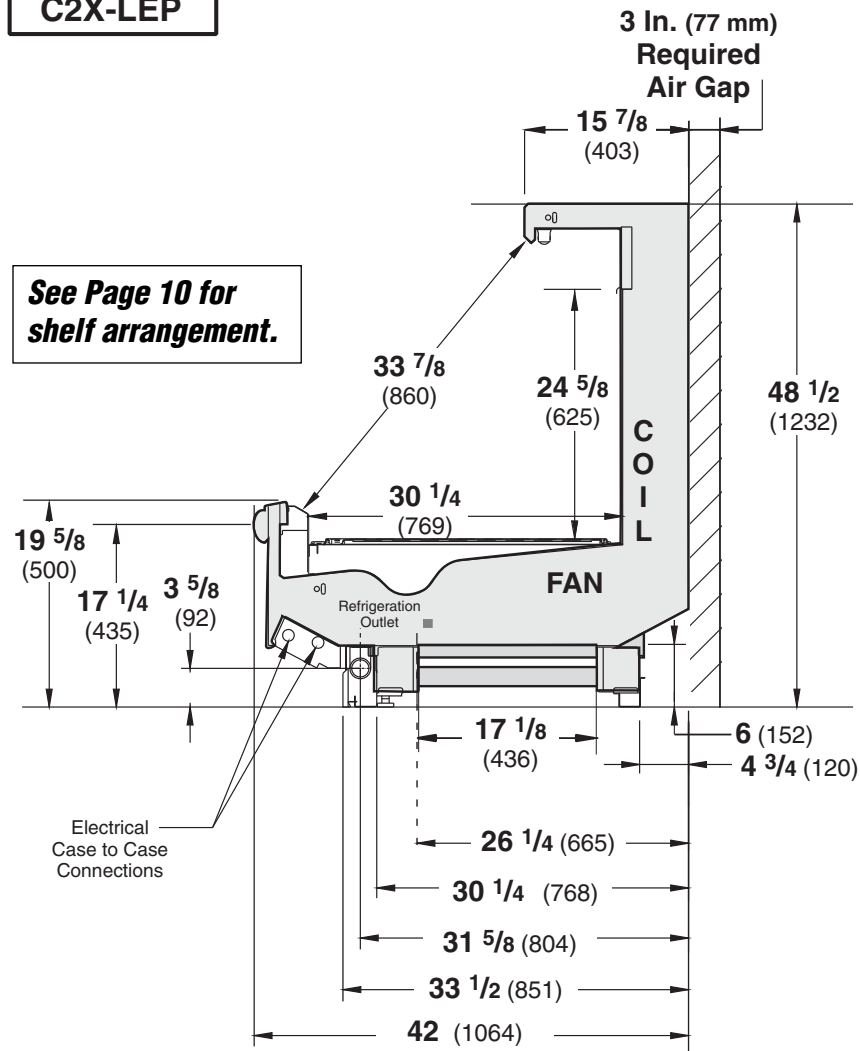

REFRIGERATION DATA

Note: This data is based on store temperature and humidity that does not exceed 75°F and 55% R.H.

	C2X-LEP Dairy/Deli/Produce		Meat	
	UNLIT	LIT	UNLIT	LIT
Discharge Air °F	33	31	30	28
Evaporator °F	28	26	25	23
Unit Sizing °F	26	24	23	21

Btu/hr/ft ‡ — *Unlit Shelves* ††

	C2X-LEP Dairy/Deli/Produce	Meat
PARALLEL	665	700
CONVENTIONAL	680	715

‡ Optional energy efficient motors reduce the refrigeration load by 21 Btu/hr/ft (4 ft, 8 ft and 12 ft models) and 18 Btu/hr/ft (6 ft models).
 †† Add 10 Btu/hr/ft *per shelf row* for LED fixtures.
 Add 20 Btu/hr/ft *per shelf row* for fluorescent lamps.

DEFROST DATA

	C2X-LEP
Frequency (hr)	12
Defrost Water (lb/ft/day)	6

(±15% based on case configuration and product loading.)

	C2X-LEP
OFFTIME	
Time (minutes)	30

ELECTRIC OR GAS Not Recommended

CONVENTIONAL CONTROLS

Low Pressure Backup Control

	C2X-LEP Dairy/Deli/Produce	Meat
CI/CO*	19°F / 9°F	16°F / 6°F

Indoor Unit Only, Pressure Defrost

Termination*	48°F
--------------	------

*Use a Temperature Pressure Chart to determine PSIG conversions.

	C2X-LEP		
Estimated Charge **			
4 ft	1.4 lb	22 oz	0.6 kg
6 ft	1.9 lb	30 oz	0.9 kg
8 ft	2.7 lb	43 oz	1.2 kg
12 ft	3.9 lb	62 oz	1.8 kg

**This is an average for all refrigerant types. Actual refrigerant charge may vary by approximately half a pound.

NSF Certification

This merchandiser model is manufactured to meet ANSI/NSF (National Sanitation Foundation) Standard #7 requirements for construction, materials & cleanability.

Impact Excel C2X-LEP
Dairy/Delicatessen
Precut & Packaged Produce

Electrical Data

	4 ft	6 ft	8 ft	12 ft				
Number of Fans—7W	1	—	2	3				
Number of Fans—4W	—	2	—	—				
	Amperes				Watts			
	4 ft	6 ft	8 ft	12 ft	4ft	6 ft	8 ft	12 ft
Evaporator Fan								
120V 60Hz Standard	0.50	0.62	1.00	1.50	39	48	78	117
120V 50Hz Standard	0.55	0.76	1.10	1.65	42	54	84	126
230V 60Hz Export	0.25	0.30	0.50	0.75	39	48	78	117
230V 50Hz Export	0.28	0.36	0.56	0.84	42	54	84	126
120V 60Hz Energy Efficient	0.19	0.24	0.38	0.57	14	16	28	42
230V 60Hz Energy Efficient	0.10	0.12	0.20	0.30	14	16	28	42
Minimum Circuit Ampacity †								
120V 60Hz Standard	0.70	0.82	1.20	1.70				
120V 50Hz Standard	0.75	0.96	1.30	1.85				
230V 60Hz Export	0.45	0.50	0.70	0.95				
230V 50Hz Export	0.48	0.56	0.76	1.04				
120V 60Hz Energy Efficient	0.39	0.44	0.58	0.77				
230V 60Hz Energy Efficient	0.30	0.32	0.40	0.50				
Maximum Over Current Protection 120V	20	20	20	20				
Maximum Over Current Protection 230V	15	15	15	15				
Anti-sweat Heaters								
120V 50/60Hz Standard	0.10	0.15	0.20	0.30	12	18	24	36
Standard Lighting (T-8 Fluorescent)								
1 Row Canopy	0.26	0.51	0.51	0.77	30	59	59	85
Optional Lighting (T-8 Fluorescent)								
Additional 1 Row Canopy	0.26	0.51	0.51	0.77	30	59	59	85
1 Row Rail Light	0.26	0.51	0.51	0.77	30	59	59	85
2 Rows of Shelves	0.51	1.02	1.02	1.54	59	118	118	170
Optional EcoShine LED Lighting — Normal CRI								
2 Row Canopy	0.28	0.41	0.55	0.82	33	49	66	98
2 Rows of shelves	0.20	0.29	0.39	0.58	24	35	47	70
Optional EcoShine LED Lighting — High CRI								
2 Row Canopy	0.32	0.47	0.63	0.93	38	56	75	112
2 Rows of Shelves	0.23	0.35	0.47	0.70	28	42	56	84
Optional Always*Bright LED Lighting								
2 Row Canopy	0.38	0.55	0.71	1.08	45	66	85	130
2 Rows of Shelves	0.26	0.34	0.47	0.67	31	41	56	80

120V Lighting Circuit Total = Standard Lighting + Total Optional Lighting + Optional Shelf Lighting

230V Lighting Circuit Total = Multiply 120V Lighting Circuit Total by 0.52

† MCA does not include Canopy A/S Heaters because heaters are wired separately from fans.

Product Data

Recommended Usable Cube ¹ (Cu Ft/Ft)	3.08 ft ³ /ft (0.29 m ³ /m)
AHRI Total Display Area ² (Sq Ft/Ft)	3.11 ft ² /ft (0.95 m ² /m)
Shelf Area ³ (Sq Ft/Ft)	5.04 ft ² /ft (1.54 m ² /m)

- ¹ AHRI Refrigerated Volume less shelving and other unusable space: Refrigerated Volume/Unit of Length, ft³/ft [m³/m]
² Computed using AHRI 1200 standard methodology: Total Display Area, ft² [m²]/Unit of Length, ft [m]
³ Shelf surface area is composed of bottom deck plus standard shelf complement, as shown in the Hussmann **Product Reference Guide**. The standard shelf complement for this model is (1) row of 12-inch shelf and (1) row of 18-inch shelf.

ESTIMATED SHIPPING WEIGHT ⁴					
Case					Solid End
	<i>4 ft</i>	<i>6 ft</i>	<i>8 ft</i>	<i>12 ft</i>	<i>(each)</i>
lb (kg)	600 (272)	800 (363)	1000 (454)	1200 (544)	75 (34)

⁴ Actual weights will vary according to optional kits included.

PARTS LIST (Continued from Page 1)							
Item	Part #	Description			Item	Part #	Description
LED FIXTURES AND POWER SUPPLY							
F.	0501213	Power Supply (EP.4481861)		(6)	G.	(CONTINUED) EcoShine LED Canopy Fixture	
G.	EcoShine LED Canopy Fixture			(7)	4441713	Rear 36-inch	2900K HCRI
	4441720	Front 48-inch	2900K	HCRI	4441715	Rear 36-inch	3500K HCRI
	4441722	Front 48-inch	3500K	HCRI	4441717	Rear 36-inch	3500K
	4441724	Front 48-inch	3500K		4441719	Rear 36-inch	4100K
	4441726	Front 48-inch	4100K		H.	EcoShine LED Shelf Fixture	
	4441721	Rear 48-inch	2900K	HCRI	4441590	48-inch	2900K HCRI
	4441723	Rear 48-inch	3500K	HCRI	4441591	48-inch	3500K HCRI
	4441725	Rear 48-inch	3500K		4441592	48-inch	3500K
	4441727	Rear 48-inch	4100K		4441593	48-inch	4100K
	4441712	Front 36-inch	2900K	HCRI	4441586	36-inch	2900K HCRI
	4441714	Front 36-inch	3500K	HCRI	4441587	36-inch	3500K HCRI
	4441716	Front 36-inch	3500K		4441588	36-inch	3500K
	4441718	Front 36-inch	4100K		4441589	36-inch	4100K

Note: Always*Bright lamps will be replaced with the latest generation of EcoShine lamps.

Fan Wiring Offtime Defrost

1, 2 & 3 Fans

4 ft — 1 Fan
6 ft — 2 Fans
8 ft — 2 Fans
12 ft — 3 Fans

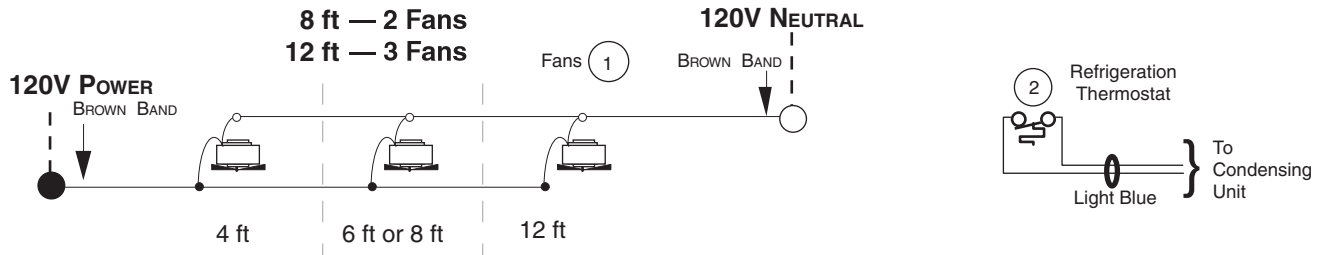

Canopy Light Circuits — Fluorescent Fixtures

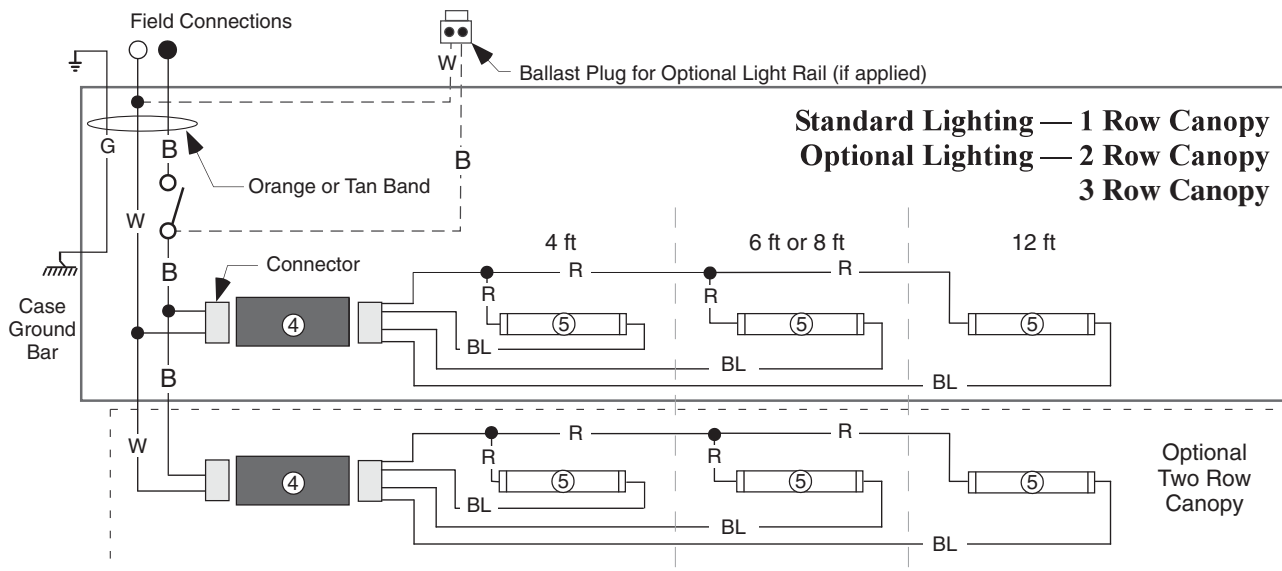

Optional Lighting — 1 Row Rail

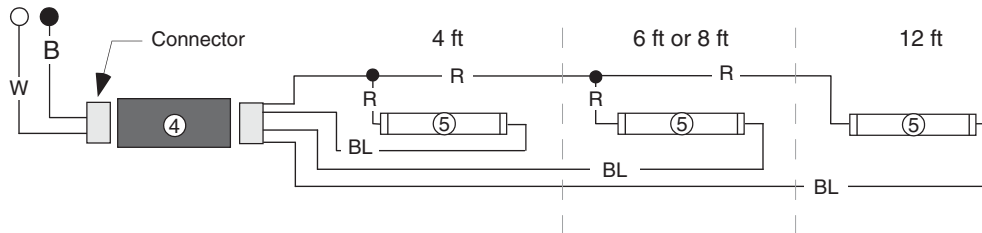

WARNING

All components must have mechanical ground, and the merchandiser must be grounded.

CIRCLED NUMBERS = PARTS LIST ITEM NUMBERS

R = Red Y = Yellow G = Green BL = Blue BK = Black W = White

● = 120V POWER ○ = 120V NEUTRAL ⊥ = FIELD GROUND ≡ = CASE GROUND

Canopy Anti-Sweat Heater

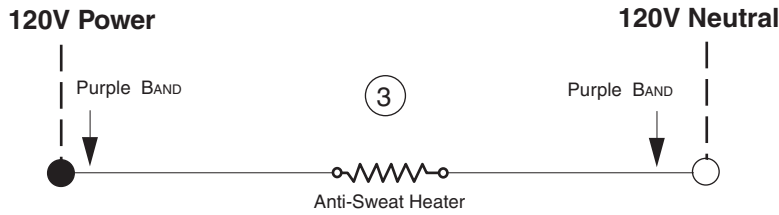

Optional Shelf Lighting Fluorescent Fixtures

Optional Shelf Harness and Fluorescent Light Circuits for Two Rows of Shelves

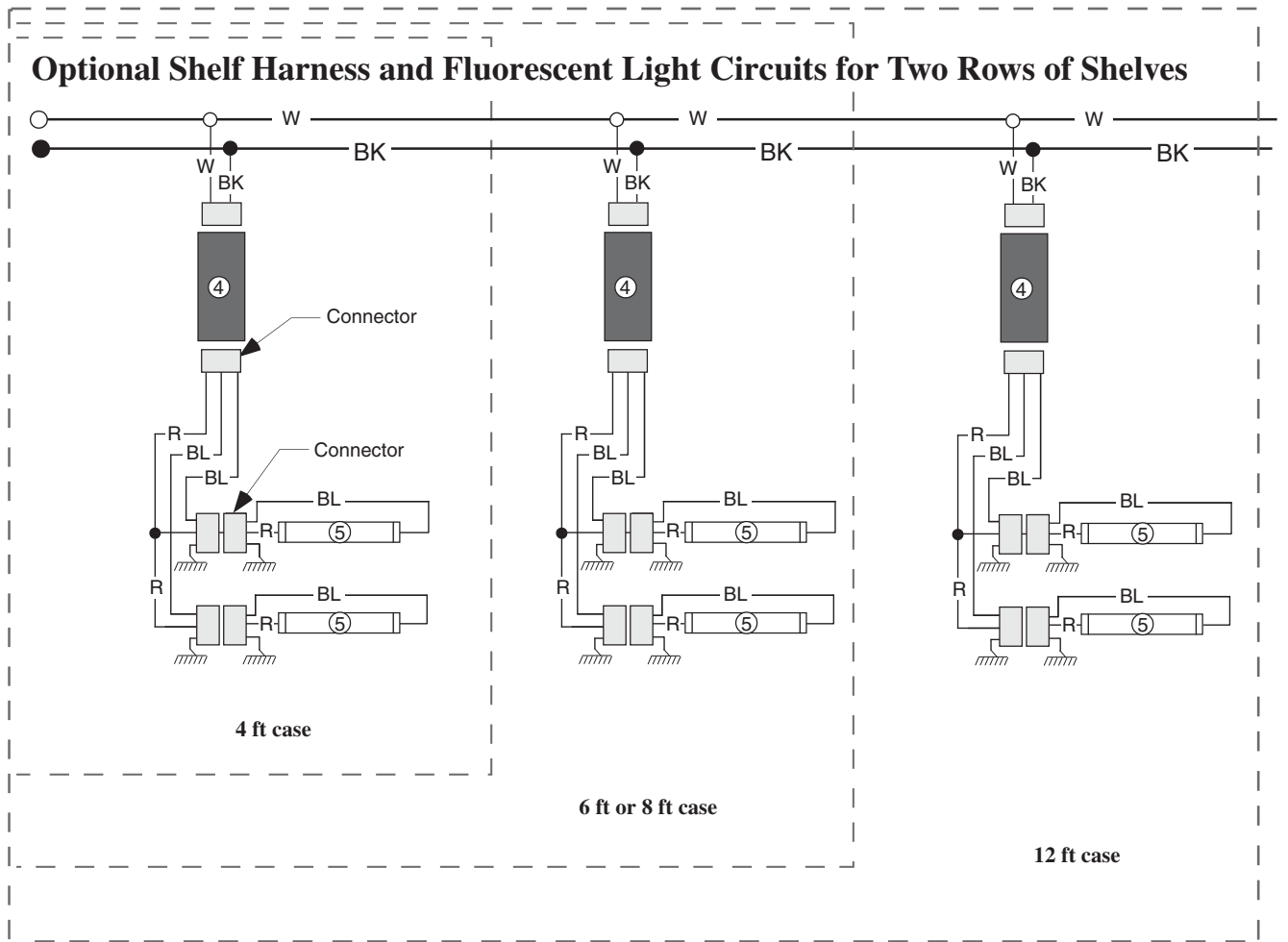

WARNING

All components must have mechanical ground, and the merchandiser must be grounded.

CIRCLED NUMBERS = PARTS LIST ITEM NUMBERS

R = Red Y = Yellow G = Green BL = Blue BK = Black W = White

● = 120V POWER ○ = 120V NEUTRAL ⊥ = FIELD GROUND ⏏ = CASE GROUND

Optional Canopy Lighting LED Fixtures

Standard LED Canopy Lighting — 2 Row Canopy

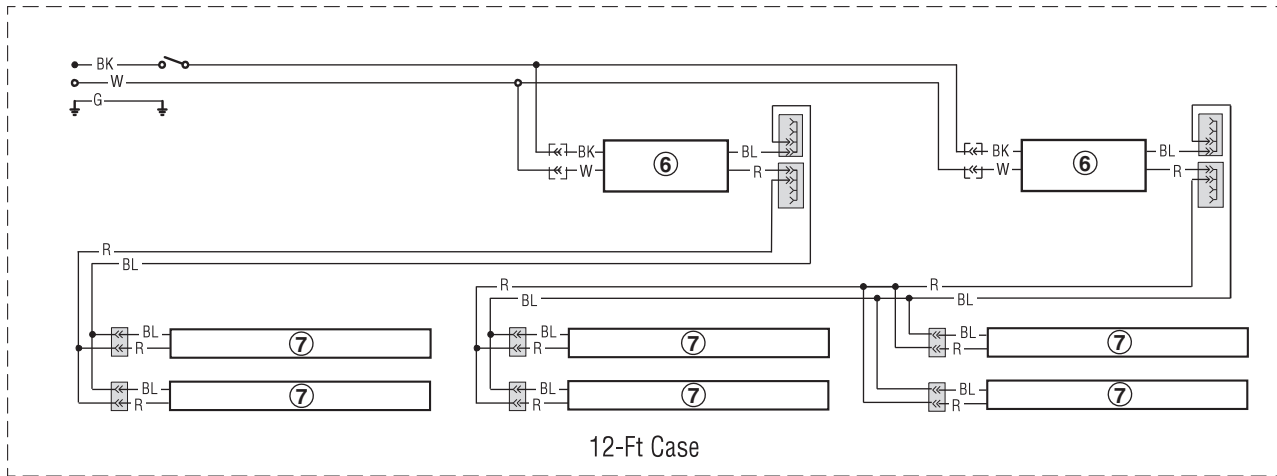
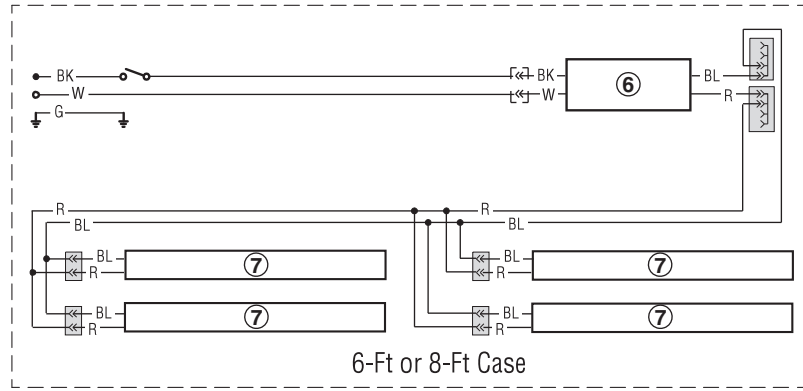
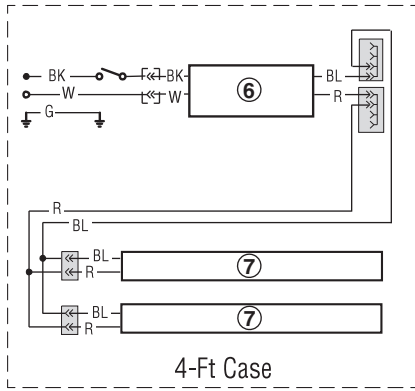

WARNING

All components must have mechanical ground, and the merchandiser must be grounded.

CIRCLED NUMBERS = PARTS LIST ITEM NUMBERS

R = Red Y = Yellow G = Green BL = Blue BK = Black W = White

● = 120V POWER ○ = 120V NEUTRAL ⊥ = FIELD GROUND ≡ = CASE GROUND

Optional Shelf Lighting LED Fixtures

Optional Shelf Harness and LED Light Circuits for Two Rows of Shelves

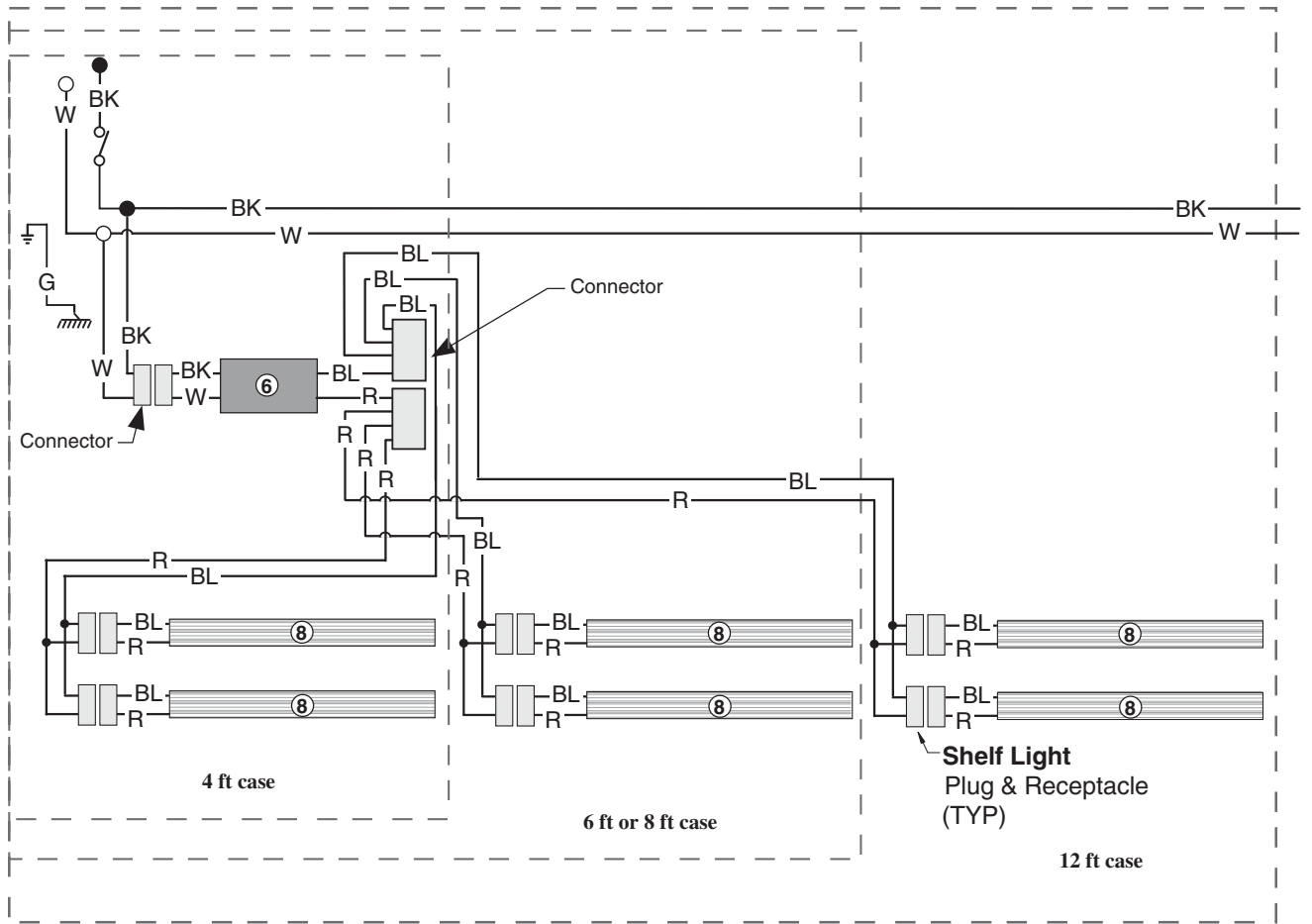

WARNING

All components must have mechanical ground, and the merchandiser must be grounded.

CIRCLED NUMBERS = PARTS LIST ITEM NUMBERS

R = Red G = Green BL = Blue BK = Black W = White

● = 120V POWER ○ = 120V NEUTRAL ⚡ = FIELD GROUND m̄m̄ = CASE GROUND

Impact Excel C2X-LEP
Dairy/Delicatessen
Precut & Packaged Produce

SHELF CONFIGURATION

This merchandiser is designed for one or two shelves.

The depth of the shelf used in the top eight (8) shelf hole locations is critical to case performance.

If a shelf is placed in one of the top eight (8) locations it must comply with the angle/depth requirements listed below.

Shelf Angle	Maximum Shelf Depth
0 °	12 in.
15 °	14 in. or less
30 °	18 in. or less
45 °	18 in. or less

NOTE: Shelves placed in the lower positions may be up to 18 in. deep when positioned at a 0 ° angle.

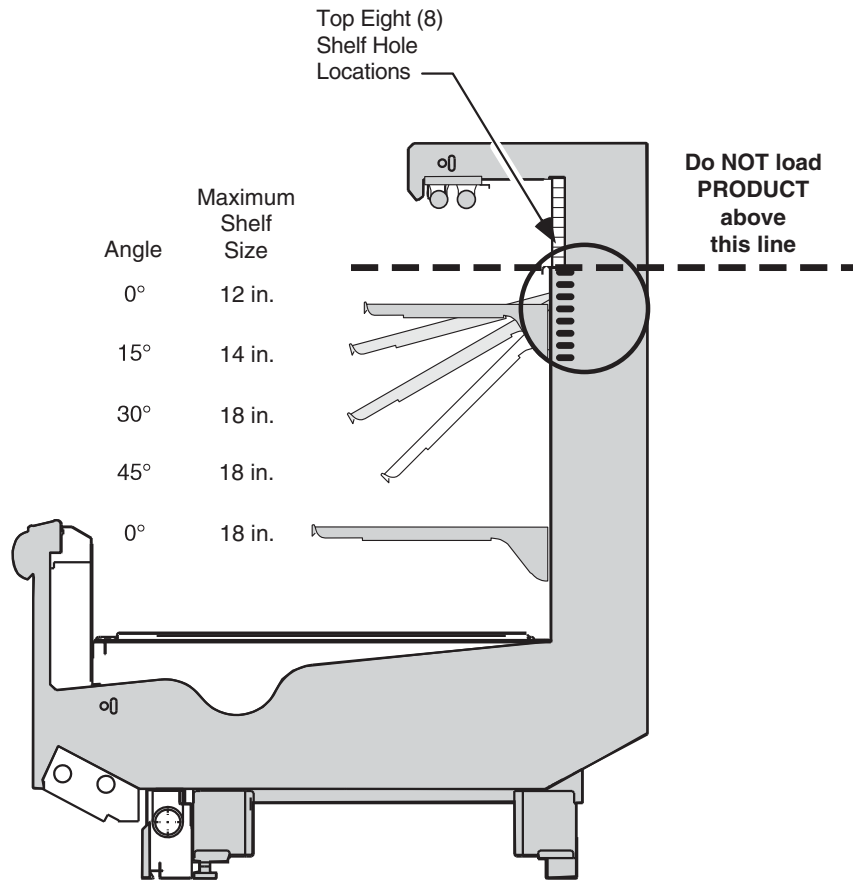

Impact Excel C2X-LEP
Dairy/Delicatessen
Precut & Packaged Produce

The ballast for the canopy and shelf lamps is located behind the canopy on the left-hand end (when facing case) of the merchandiser.

To access the ballast:

1. Remove screws at bottom edge of canopy and rear of light channel.
2. Lower light channel which will pivot on hinge.
3. Service or replace ballasts as required.
4. Reassemble items as they were originally installed.

NOTE: Rail lamp ballast is located in the electrical raceway.

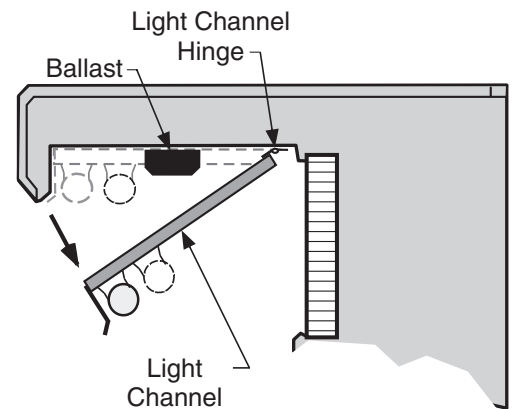
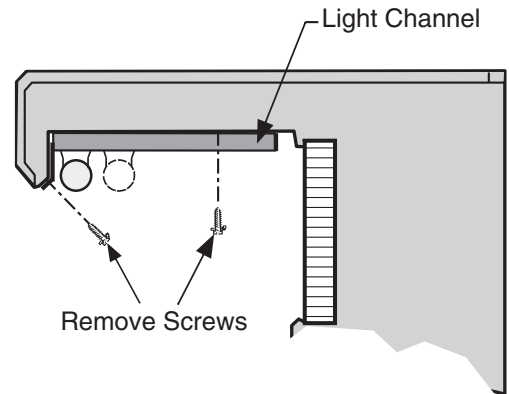

CANOPY ANTI-SWEAT HEATER

The canopy anti-sweat heater location is shown below. Connections are in the electrical wireway.

