

We reserve the right to change or revise specifications and product design in connection with any feature of our products. Such changes do not entitle the buyer to corresponding changes, improvements, additions or replacements for equipment previously sold or shipped.

Item	Part #	Description	Wiring Item #	Item	Part #	Description	Wiring Item #
FAN ASSEMBLIES				THERMOSTATS			
8 Ft & 12 Ft				B.	0382028	Standard Non-adjustable Defrost Thermostat (CT.0382028)	(2)
A.	4W Standard Energy Efficient Fan Assembly (1)			C.		Optional Adjustable Refrigeration Thermostat	(3)
	0477653	Fan Motor, Evaporator (MO.4410544)		LAMPS AND BALLASTS			
	0464847	Fan Blade (FB.4780649)		None			

Data sheet-Excel-P1X-XE

Note: Revision J: Added high glide refrigerant note. Other changes marked by bar, underline or circle.

Engineering Plan Views

PHYSICAL DATA	
Merchandiser Drip Pipe (in.)	1 1/4
Merchandiser Liquid Line (in.)	3/8
Merchandiser Suction Line (in.)	5/8

Bulk Produce



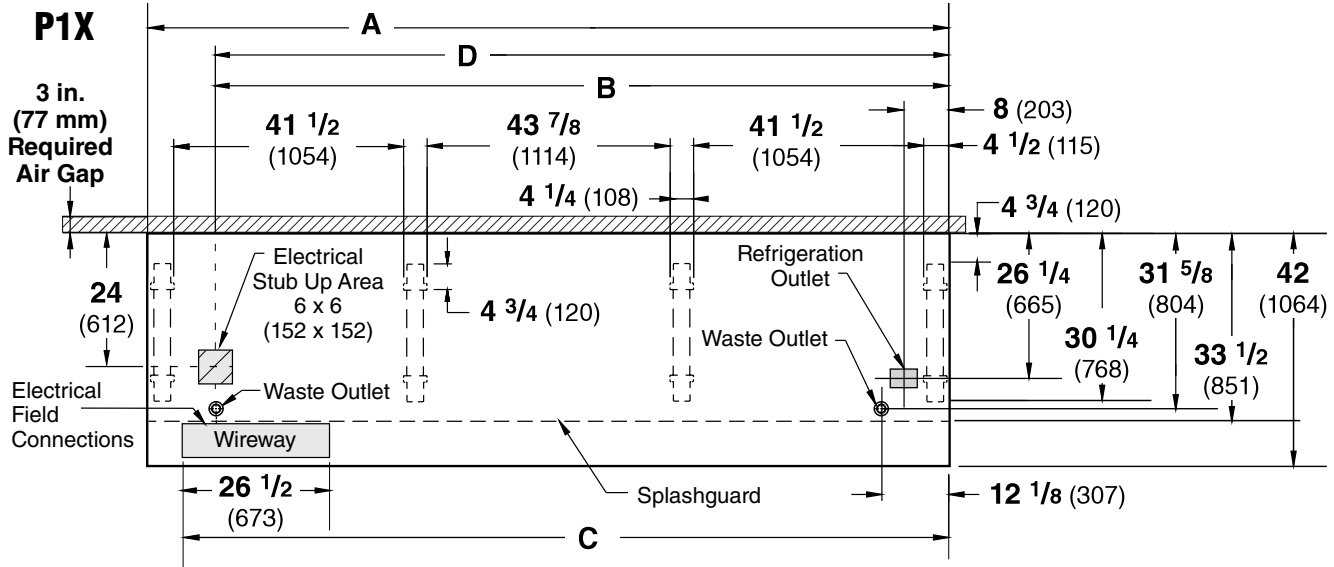

09-2005

Dimensions shown as in. and (mm).



NOTE: Case-to-Case Electrical Connections are made IN FRONT OF SPLASHGUARD.

FRONT

	4 ft	8 ft	12 ft
General			
(A) Case Length <i>(without ends or partitions)</i> <i>(Each end and insulated partition adds 1 1/2 in. (38 mm) to case line up.)</i> Maximum O/S dimension of case back to front <i>(includes bumper)</i>	48 3/8 (1229)	96 3/8 (2448)	144 1/2 (3670)
Back of case to front of splashguard	42 (1064)	42 (1064)	42 (1064)
Back of case to O/S edge of front leg	33 1/2 (851)	33 1/2 (851)	33 1/2 (851)
Distance between edges of external legs and center legs	NA	41 1/2 (1054)	41 1/2 (1054)
Distance between edges of center legs	NA	NA	43 7/8 (1114)
Distance between front legs and splashguard	2 3/4 (70)	2 3/4 (70)	2 3/4 (70)
Electrical Service  <i>(Electrical Field Wiring connection point)</i>			
(B) RH End of case to center of stub up area	36 1/4 (921)	84 1/4 (2140)	132 3/8 (3363)
Back of case to center of stub up area	24 (612)	24 (612)	24 (612)
Length of electrical wireway 	26 1/2 (673)	26 1/2 (673)	26 1/2 (673)
(C) RH End of case to LH end of wireway	42 1/8 (1070)	90 1/8 (2289)	138 1/4 (3511)
Waste Outlets <i>(One each end)</i> 			
(D) RH End of case to the center of LH waste outlet	36 1/4 (921)	84 1/4 (2140)	132 3/8 (3363)
RH End of case to the center of RH waste outlet	12 1/8 (307)	12 1/8 (307)	12 1/8 (307)
Back O/S of case to center of waste outlets	31 5/8 (804)	31 5/8 (804)	31 5/8 (804)
Schedule 40 PVC drip pipe	1 1/4 (32)	1 1/4 (32)	1 1/4 (32)
Refrigeration Outlet 			
Back of case to center of refrigeration outlet	26 1/4 (665)	26 1/4 (665)	26 1/4 (665)
RH end of case to center of refrigeration outlet	8 (203)	8 (203)	8 (203)

Single Deck with High Back, 1 Display Level



Husmann refrigerated merchandisers configured for sale for use in the United States meet or surpass the requirements of the DOE 2017 energy efficiency standards.

Dimensions shown as inches and (mm).

P1X-XE

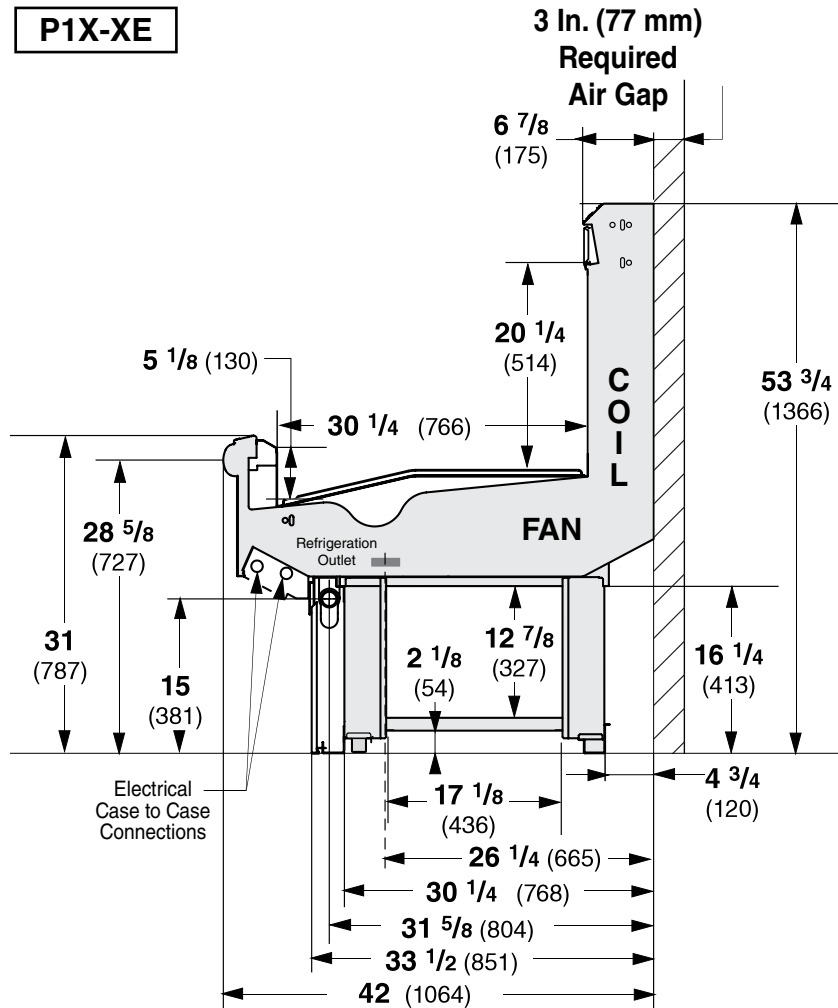

Estimated Charge**		PIX-XE	
4 ft	0.9 lb 14 Oz	0.4 kg	
8 ft	1.7 lb 27 Oz	0.8 kg	
12 ft	2.3 lb 37 Oz	1.0 kg	

**This is an average for all refrigerant types. Actual refrigerant charge may vary by approximately half a pound (8 oz/0.2 kg).

NSF Certification

This merchandiser model is manufactured to meet NSF/ANSI (National Sanitation Foundation) Standard #7 requirements for construction, materials & cleanability.

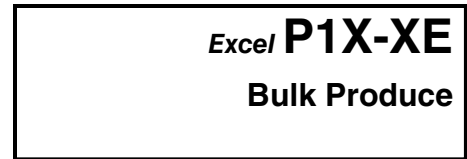

REFRIGERATION DATA

Note: This data is based on store temperature and humidity that does not exceed 75°F and 55% R.H.

	PIX-XE§
Discharge Air (°F)	31
Evaporator (°F)	24
Unit Sizing (°F)	22
§ Average evaporator temperature shown. Use dew point for high glide refrigerants for unit sizing. Care should be taken to use the dew point in PT tables for measuring and adjusting superheat. Adjust evaporator pressure as needed to maintain discharge air temperature shown.	
<i>Btu/hr/ft</i>	PIX-XE
Parallel	611
Conventional	651

DEFROST DATA

	PIX-XE
Frequency (hr)	8
Defrost Water (lb/ft/day)	4
(± 15% based on case configuration and product loading).	
<i>OFFTIME</i>	PIX-XE
Temp Term (°F)	43°F
Failsafe (minutes)	35

ELECTRIC OR GAS Not Recommended

Standard Defrost Thermostat

Close on rise: close 43°F — open 33°F

CONVENTIONAL CONTROLS

Low Pressure Backup Control

	PIX-XE
C/CO*	17°F / 7°F

Indoor Unit Only, Pressure Defrost

Termination* 48°F

*Use a Temperature Pressure Chart to determine PSIG conversions.

Excel P1X-XE**Bulk Produce****Electrical Data**

	4 ft	8 ft	12 ft
Number of Fans—4W	1	2	3

			Amperes			Watts		
			4 ft	8 ft	12 ft	4 ft	8 ft	12 ft
Evaporator Fan								
120V	50/60Hz	Standard Energy Efficient	0.12	0.24	0.36	8	16	24
230V	50/60Hz	Standard Energy Efficient	0.06	0.12	0.18	8	16	24
230V	60Hz	Export	0.15	0.30	0.45	24	48	72
230V	50Hz	Export	0.18	0.36	0.54	27	54	81

Minimum Circuit Ampacity

120V	50/60Hz	Standard Energy Efficient	0.32	0.44	0.56
230V	50/60Hz	Standard Energy Efficient	0.26	0.32	0.38
230V	60Hz	Export	0.35	0.50	0.65
230V	50Hz	Export	0.38	0.56	0.74

Maximum Over Current Protection 120V	20	20	20
Maximum Over Current Protection 230V	15	15	15

Product Data

<i>Recommended Usable Cube</i> ¹ (Cu Ft/Ft)	2.64 ft ³ /ft (0.25 m ³ /m)
<i>AHRI Total Display Area</i> ² (Sq Ft/Ft)	3.01 ft ² /ft (0.92 m ² /m)
<i>Shelf Area</i> ³ (Sq Ft/Ft)	2.53 ft ² /ft (0.77 m ² /m)

- ¹ AHRI Refrigerated Volume less shelving and other unusable space: Refrigerated Volume/Unit of Length, ft³/ft [m³/m]
- ² Computed using AHRI 1200 standard methodology: Total Display Area, ft² [m²]/Unit of Length, ft [m]
- ³ Shelf surface area is composed of bottom deck plus standard shelf complement, as shown in the Hussmann *Product Reference Guide*. The standard shelf complement for this model is NONE.

ESTIMATED SHIPPING WEIGHT⁴

Case	4 ft	8 ft	12 ft	Solid End (each)
lb (kg)	500 (227)	900 (408)	1000 (454)	50 (23)

⁴ Actual weights will vary according to optional kits included.

**Fan Wiring
Offtime Defrost**

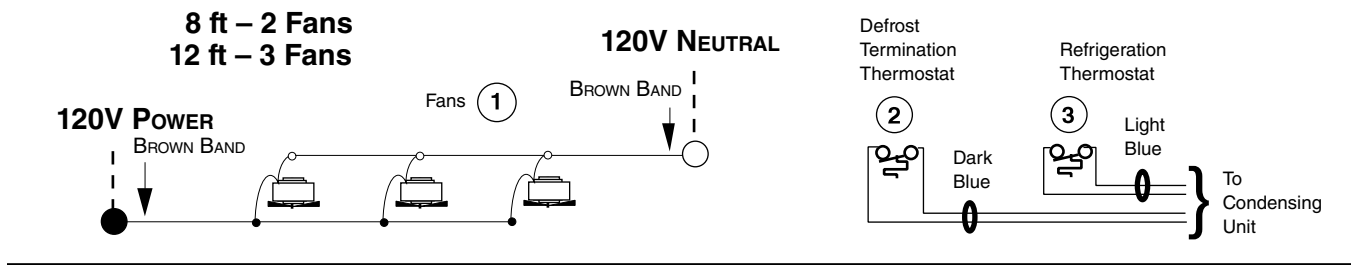

WARNING

All components must have mechanical ground, and the merchandiser must be grounded.

CIRCLED NUMBERS = PARTS LIST ITEM NUMBERS

● = 120V POWER ○ = 120V NEUTRAL