

HUSSMANN[®] Excel



C3X-LGE
Technical Data Sheet
P/N 0477979_E

NSF[®] Certified

March 2010

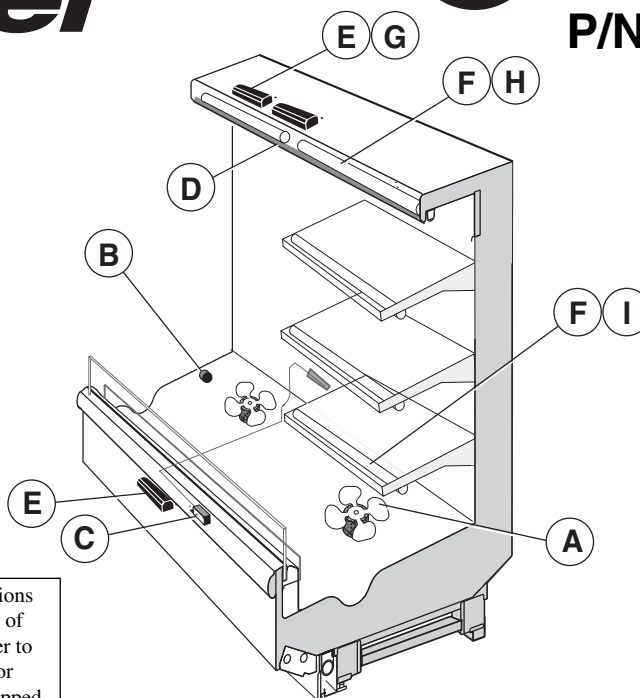

We reserve the right to change or revise specifications and product design in connection with any feature of our products. Such changes do not entitle the buyer to corresponding changes, improvements, additions or replacements for equipment previously sold or shipped.

Item	Part #	Description	Wiring Item #	Item	Part #	Description	Wiring Item #
FAN ASSEMBLIES				HEATERS			
8 Ft & 12 Ft				D.		Canopy Anti-Sweat Heater	(4)
A.	12W Standard	Fan Assembly	(1)	0488622	6 ft (HE.4850617)		
	0047000	Fan Motor, Evaporator (MO.4410103)		0488623	8 ft (HE.4850618)		
	0461805	Fan Blade (FB.4780446)		0488624	12 ft (HE.4850619)		
	12W Energy Efficient	Fan Assembly	(1)	LAMPS AND BALLASTS			
	0477655	Fan Motor, Evaporator (MO.4410546)		E.	Ballast, Electronic		(5)
	0461805	Fan Blade (FB.4780446)		0480130	2 lamps (BA.4481676)		
6 Ft Only				0480131	3 lamps (BA.4481654)		
				0480132	4 lamps (BA.4481677)		
A.	7W Standard	Fan Assembly	(1)	F.	Fluorescent Lamp		(6)
	0058698	Fan Motor, Evaporator (MO.4410102)			<i>Replace with like fixtures</i>		
	0142780	Fan Blade (FB.0142780)		LED FIXTURES AND POWER SUPPLY			
	7W Energy Efficient	Fan Assembly	(1)	G.	0501213	Power Supply (EP.4481861)	(7)
	0477654	Fan Motor, Evaporator (MO.4410545)		H.		LED Canopy Fixture	(8)
	0142780	Fan Blade (FB.0142780)				<i>Replace with like fixtures — See Page 5.</i>	
THERMOSTATS				I.		LED Shelf Fixture	(9)
B.	0411744	Standard Non-adjustable Defrost Thermostat (CT.0411744)	(2)			<i>Replace with like fixtures — See Page 5.</i>	
C.		Optional Adjustable Refrigeration Thermostat	(3)				

Note: Rev. E adds Btu note (page 3), EcoShine LED (page 4) and parts (page 5), and revises canopy wiring diagram (page 6). Other changes marked by bar, underline or circle.



Engineering Plan Views

PHYSICAL DATA	
Merchandiser Drip Pipe (in.)	1 1/4
Merchandiser Liquid Line (in.)	3/8
Merchandiser Suction Line (in.)	7/8

**Dairy/Delicatessen
Precut & Packaged Produce**
01-2005

Dimensions shown as inches and (mm).

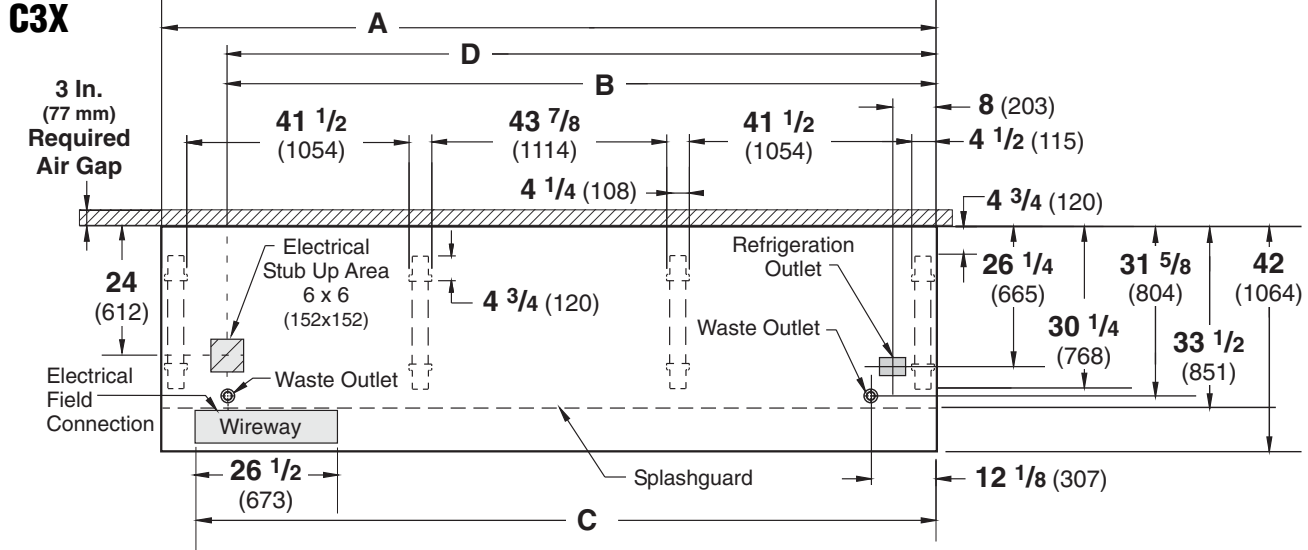

NOTE: Case-to-Case Electrical Connections are made IN FRONT OF SPLASHGUARD.

FRONT

	6 ft	8 ft	12 ft
General			
(A) Case Length (without ends or partitions) (Each end and insulated partition adds 1 1/2 in. (38 mm) to case line up.) Maximum O/S dimension of case back to front (includes bumper)	72 3/8 (1838)	96 3/8 (2448)	144 1/2 (3670)
Back of case to front of splashguard	42 (1064)	42 (1064)	42 (1064)
Back of case to O/S edge of front leg	33 1/2 (851)	33 1/2 (851)	33 1/2 (851)
Distance between edges of external legs and center legs	30 1/4 (768)	30 1/4 (768)	30 1/4 (768)
Distance between edges of center legs	29 1/2 (750)	41 1/2 (1054)	41 1/2 (1054)
Distance between front legs and splashguard	NA	NA	43 7/8 (1114)
	2 3/4 (70)	2 3/4 (70)	2 3/4 (70)
Electrical Service (Electrical Field Wiring connection point)			
(B) RH End of case to center of stub up area	60 1/4 (1530)	84 1/4 (2140)	132 3/8 (3363)
Back of case to center of stub up area	24 (612)	24 (612)	24 (612)
Length of electrical wireway	26 1/2 (673)	26 1/2 (673)	26 1/2 (673)
(C) RH End of case to LH end of wireway	66 1/8 (1680)	90 1/8 (2289)	138 1/4 (3511)
Waste Outlets (One each end)			
(D) RH End of case to the center of LH waste outlet	60 1/4 (1530)	84 1/4 (2140)	132 3/8 (3363)
RH End of case to the center of RH waste outlet	12 1/8 (307)	12 1/8 (307)	12 1/8 (307)
Back O/S of case to center of waste outlets	31 5/8 (804)	31 5/8 (804)	31 5/8 (804)
Schedule 40 PVC drip pipe	1 1/4 (32)	1 1/4 (32)	1 1/4 (32)
Refrigeration Outlet			
Back of case to center of refrigeration outlet	26 1/4 (665)	26 1/4 (665)	26 1/4 (665)
RH end of case to center of refrigeration outlet	8 (203)	8 (203)	8 (203)

Multi-deck, 4 Display Levels, Low Front with Glass

Dimensions shown as inches and (mm).

C3X-LGE

See Page 11 for shelf arrangement.

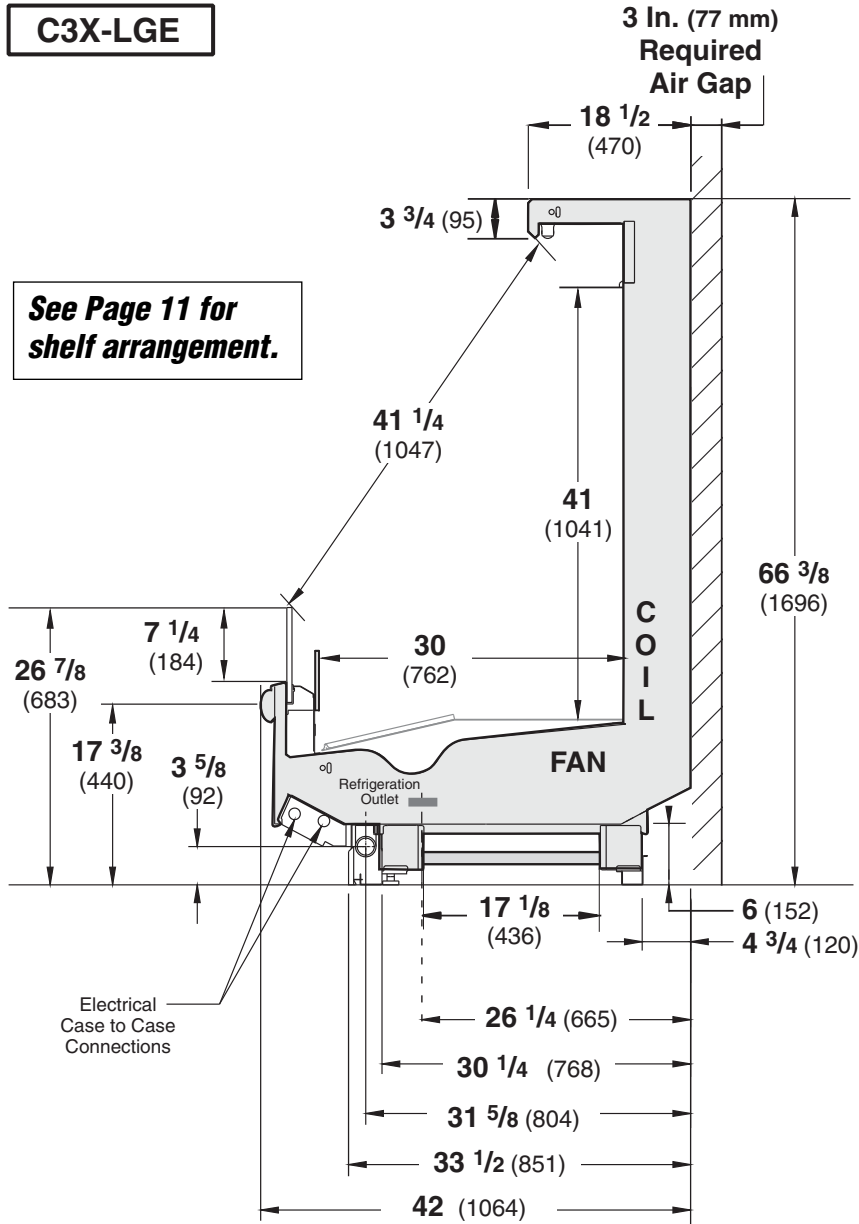

Impact Excel C3X-LGE

**Dairy / Delicatessen
Precut and Packaged Produce**

REFRIGERATION DATA

Note: This data is based on store temperature and humidity that does not exceed 75°F and 55% R.H.

	C3X-LGE
Discharge Air °F	30
Evaporator °F	21
Unit Sizing °F	19

Btu/hr/ft ‡ — Unlit Shelves ‡‡

C3X-LGE	Parallel	Conventional
UNLIT	1240	1320

‡ Optional energy efficient motors reduce the refrigeration load by 27 Btu/hr/ft.
 ‡‡ Add 10 Btu/hr/ft per shelf row for LED fixtures.
 Add 20 Btu/hr/ft per shelf row for fluorescent lamps.

DEFROST DATA

	C3X-LGE
Frequency (hr)	6
Defrost Water (lb/ft/day)	6

(±15% based on case configuration and product loading.)

OFFTIME	C3X-LGE
Temp Term °F	48°F
Failsafe Minutes	30

ELECTRIC OR GAS Not Recommended

Standard Defrost Thermostat

Close on rise: close 48°F – open 33°F

CONVENTIONAL CONTROLS

Low Pressure Backup Control

	C3X-LGE
CI/CO*	14°F / 4°F

Indoor Unit Only, Pressure Defrost

Termination*	48°F
--------------	------

*Use a Temperature Pressure Chart to determine PSIG conversions.

Estimated Charge **	C3X-LGE	
6 ft	2.0	32 oz 0.9 kg
8 ft	2.7	43 oz 1.2 kg
12 ft	3.9	62 oz 1.8 kg

**This is an average for all refrigerant types.
 Actual refrigerant charge may vary by approximately half a pound.

NSF Certification

This merchandiser model is manufactured to meet ANSI/NSF (National Sanitation Foundation) Standard #7 requirements for construction, materials & cleanability.

Impact *Excel* C3X-LGE

Dairy / Delicatessen
Precut and Packaged Produce

Electrical Data

			6 ft	8 ft	12 ft			
Number of Fans—12W			—	2	3			
Number of Fans—7W			2	—	—			
			Amperes			Watts		
			6 ft	8 ft	12 ft	6 ft	8 ft	12 ft
Evaporator Fan								
120V	60Hz	Standard	1.00	1.30	1.95	78	100	150
120V	50Hz	Standard	1.10	1.50	2.25	84	114	171
230V	60Hz	Export	0.50	0.66	0.99	78	100	150
230V	50Hz	Export	0.56	0.76	1.14	84	114	171
120V	60Hz	Energy Efficient	0.38	0.60	0.90	28	36	54
230V	60Hz	Energy Efficient	0.20	0.30	0.45	28	36	54
Minimum Circuit Ampacity								
120V	60Hz	Standard	1.20	1.50	2.15			
120V	50Hz	Standard	1.30	1.70	2.45			
230V	60Hz	Export	0.70	0.86	1.19			
230V	50Hz	Export	0.76	0.96	1.34			
120V	60Hz	Energy Efficient	0.58	0.80	1.10			
230V	60Hz	Energy Efficient	0.40	0.50	0.65			
Maximum Over Current Protection 120V			20	20	20			
Maximum Over Current Protection 230V			15	15	15			
Anti-sweat Heaters								
120V	50/60Hz	Standard	0.15	0.20	0.30	18	24	36
Standard Lighting (T-8 Fluorescent)								
1 Row Canopy			0.51	0.51	0.77	59	59	85
Optional Lighting (T-8 Fluorescent)								
Additional 1 Row Canopy			0.51	0.51	0.77	59	59	85
1 Row Rail Light			NA — Glass front does not accept rail light					
1 Row of Shelves			0.51	0.51	0.77	59	59	85
2 Rows of Shelves			1.02	1.02	1.54	118	118	170
3 Rows of Shelves			1.53	1.53	2.31	177	177	255
EcoShine Multi-deck Canopy Normal (CRI) — 120VAC, 50/60Hz								
2 Row Canopy (Front & Rear)			0.41	0.55	0.82	49	66	98
1 Row of Shelves			0.15	0.20	0.29	18	24	35
2 Rows of Shelves			0.29	0.39	0.58	35	47	70
3 Rows of Shelves			0.44	0.58	0.88	53	70	105
EcoShine Multi-deck Canopy High CRI — 120VAC, 50/60Hz								
2 Row Canopy (Front & Rear)			0.47	0.63	0.93	56	75	112
1 Row of Shelves			0.18	0.23	0.35	21	28	42
2 Rows of Shelves			0.35	0.47	0.70	42	56	84
3 Rows of Shelves			0.53	0.70	1.05	63	84	126
Always*Bright Multi-deck Canopy — 120VAC, 50/60Hz								
2 Row Canopy (Front & Rear)			0.55	0.71	1.08	66	85	130
1 Row of Shelves			0.19	0.23	0.38	23	28	45
2 Rows of Shelves			0.34	0.47	0.67	41	56	80
3 Rows of Shelves			0.53	0.74	1.11	63	89	133

120V Lighting Circuit Total = Standard Lighting + Total Optional Lighting + Optional Shelf Lighting

230V Lighting Circuit Total = Multiply 120V Lighting Circuit Total by 0.52

Product Data

Recommended Usable Cube ¹ (Cu Ft/Ft)	4.77 ft ³ /ft (0.44 m ³ /m)
AHRI Total Display Area ² (Sq Ft/Ft)	4.07 ft ² /ft (1.24 m ² /m)
Shelf Area ³ (Sq Ft/Ft)	6.02 ft ² /ft (1.84 m ² /m)

¹ AHRI Refrigerated Volume less shelving and other unusable space: Refrigerated Volume/Unit of Length, ft³/ft [m³/m]

² Computed using AHRI 1200 standard methodology: Total Display Area, ft² [m²]/Unit of Length, ft [m]

³ Shelf surface area is composed of bottom deck plus standard shelf complement, as shown in the Hussmann **Product Reference Guide**. The standard shelf complement for this model is (1) row of 12-inch shelf, (1) row of 14-inch shelf and (1) row of 16-inch shelf.

ESTIMATED SHIPPING WEIGHT ⁴				
Case				Solid End
	<i>6 ft</i>	<i>8 ft</i>	<i>12 ft</i>	<i>(each)</i>
lb (kg)	800 (363)	1000 (454)	1200 (544)	100 (45)

⁴ Actual weights will vary according to optional kits included.

PARTS LIST (Continued from Page 1)							
Item	Part #	Description			Item	Part #	Description
LED FIXTURES AND POWER SUPPLY							
G.	0501213	Power Supply (EP.4481861)			(7)	H. (CONTINUED) EcoShine LED Canopy Fixture	
H.	EcoShine LED Canopy Fixture			(8)	4441713	Rear 36-inch	2900K HCRI
	4441720	Front 48-inch	2900K	HCRI	4441715	Rear 36-inch	3500K HCRI
	4441722	Front 48-inch	3500K	HCRI	4441717	Rear 36-inch	3500K
	4441724	Front 48-inch	3500K		4441719	Rear 36-inch	4100K
	4441726	Front 48-inch	4100K		I. EcoShine LED Shelf Fixture		(9)
	4441721	Rear 48-inch	2900K	HCRI	4441590	48-inch	2900K HCRI
	4441723	Rear 48-inch	3500K	HCRI	4441591	48-inch	3500K HCRI
	4441725	Rear 48-inch	3500K		4441592	48-inch	3500K
	4441727	Rear 48-inch	4100K		4441593	48-inch	4100K
	4441712	Front 36-inch	2900K	HCRI	4441586	36-inch	2900K HCRI
	4441714	Front 36-inch	3500K	HCRI	4441587	36-inch	3500K HCRI
	4441716	Front 36-inch	3500K		4441588	36-inch	3500K
	4441718	Front 36-inch	4100K		4441589	36-inch	4100K

Note: Always*Bright lamps will be replaced with the latest generation of EcoShine lamps.

Fan Wiring Offtime Defrost

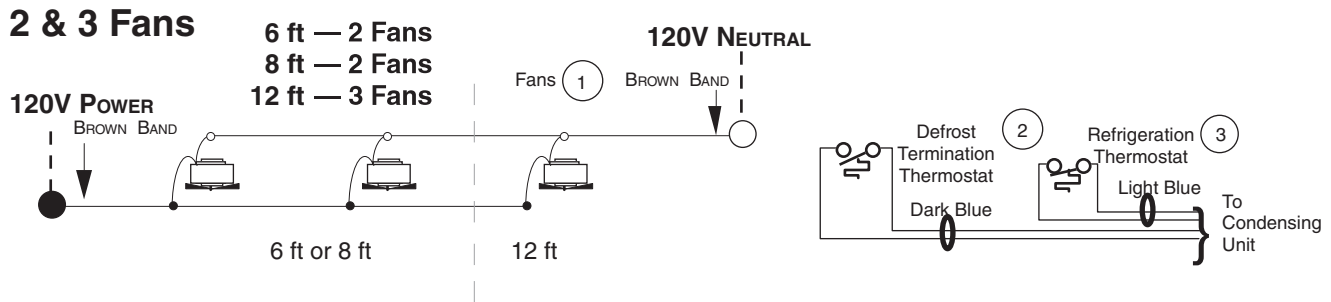

Canopy Light Circuits — Fluorescent Fixtures

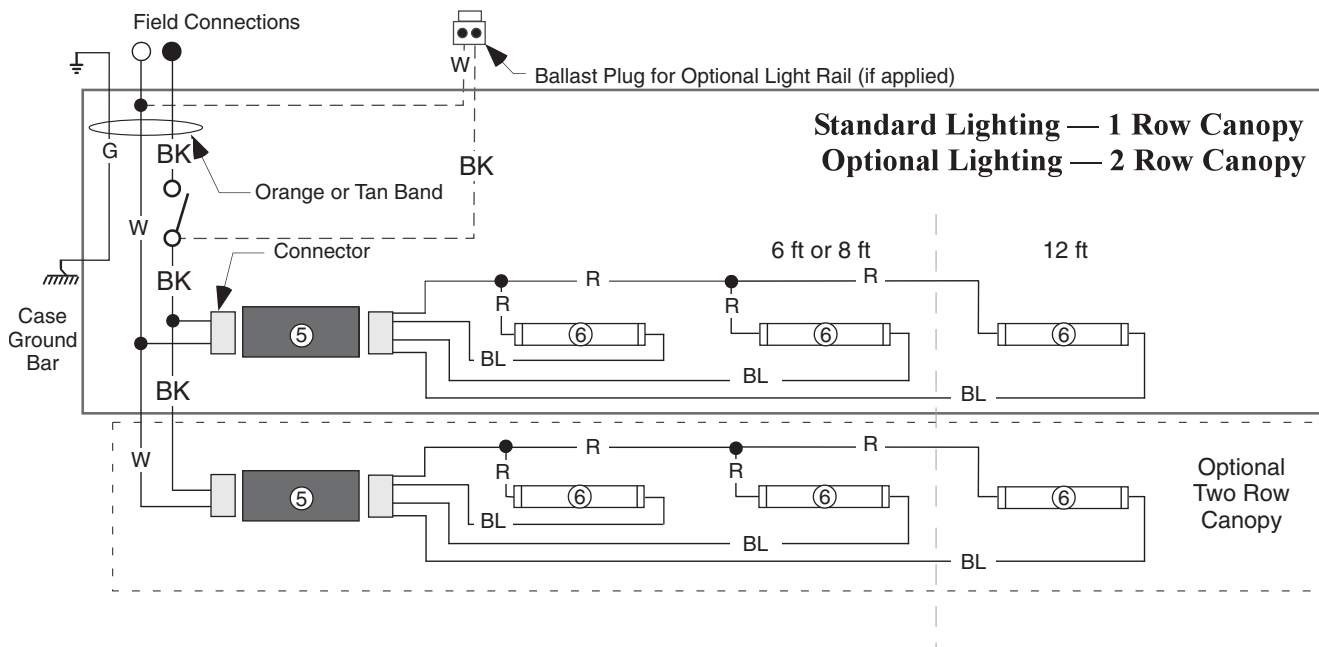

WARNING

All components must have mechanical ground, and the merchandiser must be grounded.

CIRCLED NUMBERS = PARTS LIST ITEM NUMBERS

R = Red Y = Yellow G = Green BL = Blue BK = Black W = White

● = 120V POWER ○ = 120V NEUTRAL ⊥ = FIELD GROUND $\overline{\overline{\overline{\text{m}}}}$ = CASE GROUND

Canopy Anti-Sweat Heater

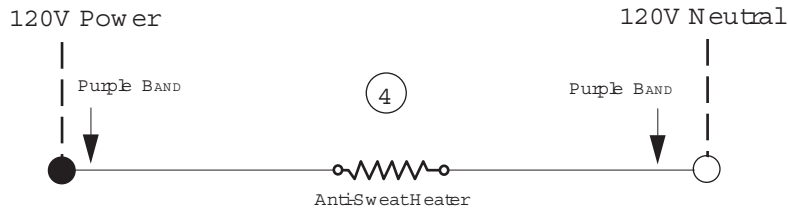

Optional Shelf Lighting Fluorescent Fixtures

Optional Shelf Harness and Light Circuits for Three Rows of Shelves

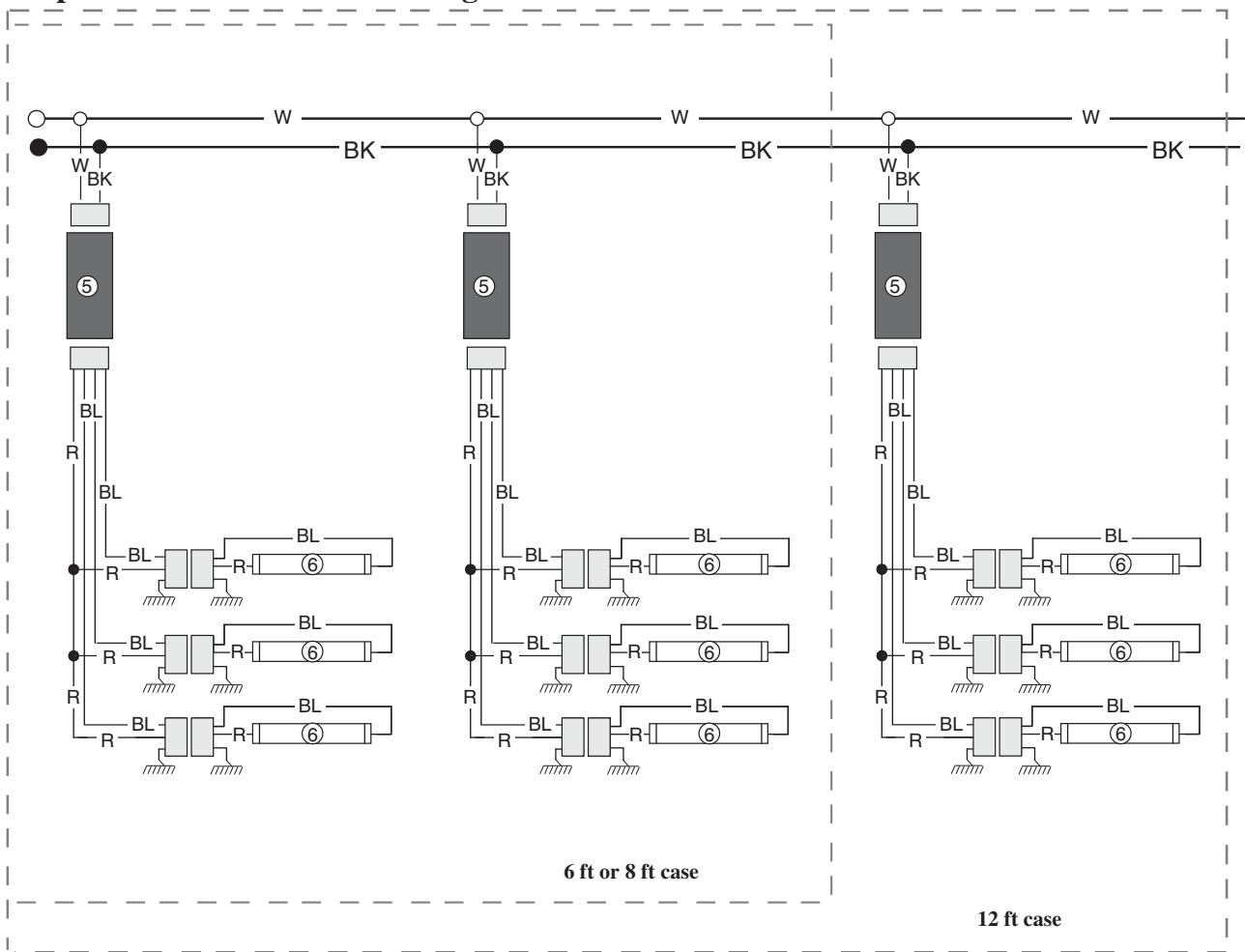

WARNING

All components must have mechanical ground, and the merchandiser must be grounded.

CIRCLED NUMBERS = PARTS LIST ITEM NUMBERS

R = Red Y = Yellow G = Green BL = Blue BK = Black W = White

● = 120V POWER ○ = 120V NEUTRAL ⊥ = FIELD GROUND ≡ = CASE GROUND

Optional Canopy Lighting LED Fixtures

Standard LED Canopy Lighting — 2 Row Canopy

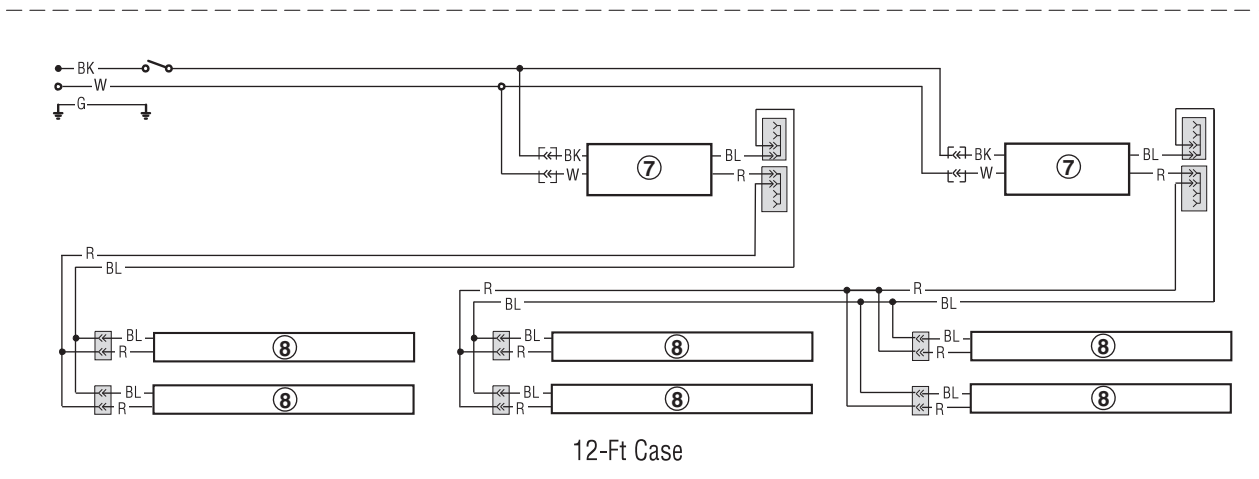
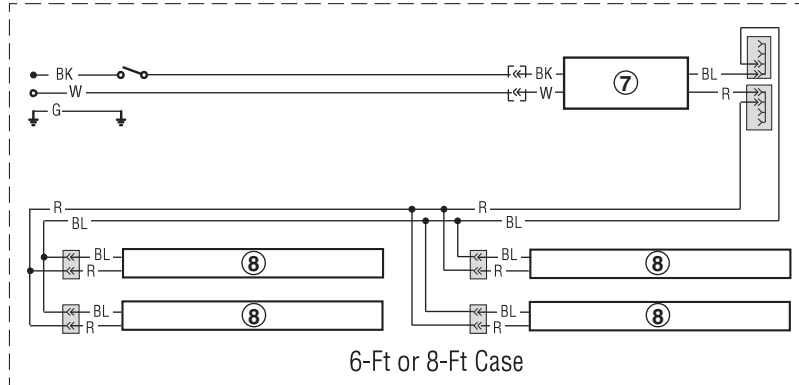

WARNING

All components must have mechanical ground, and the merchandiser must be grounded.

CIRCLED NUMBERS = PARTS LIST ITEM NUMBERS

R = Red Y = Yellow G = Green BL = Blue BK = Black W = White

● = 120V POWER ○ = 120V NEUTRAL ⚡ = FIELD GROUND ⏏ = CASE GROUND

Optional Shelf Lighting LED Fixtures

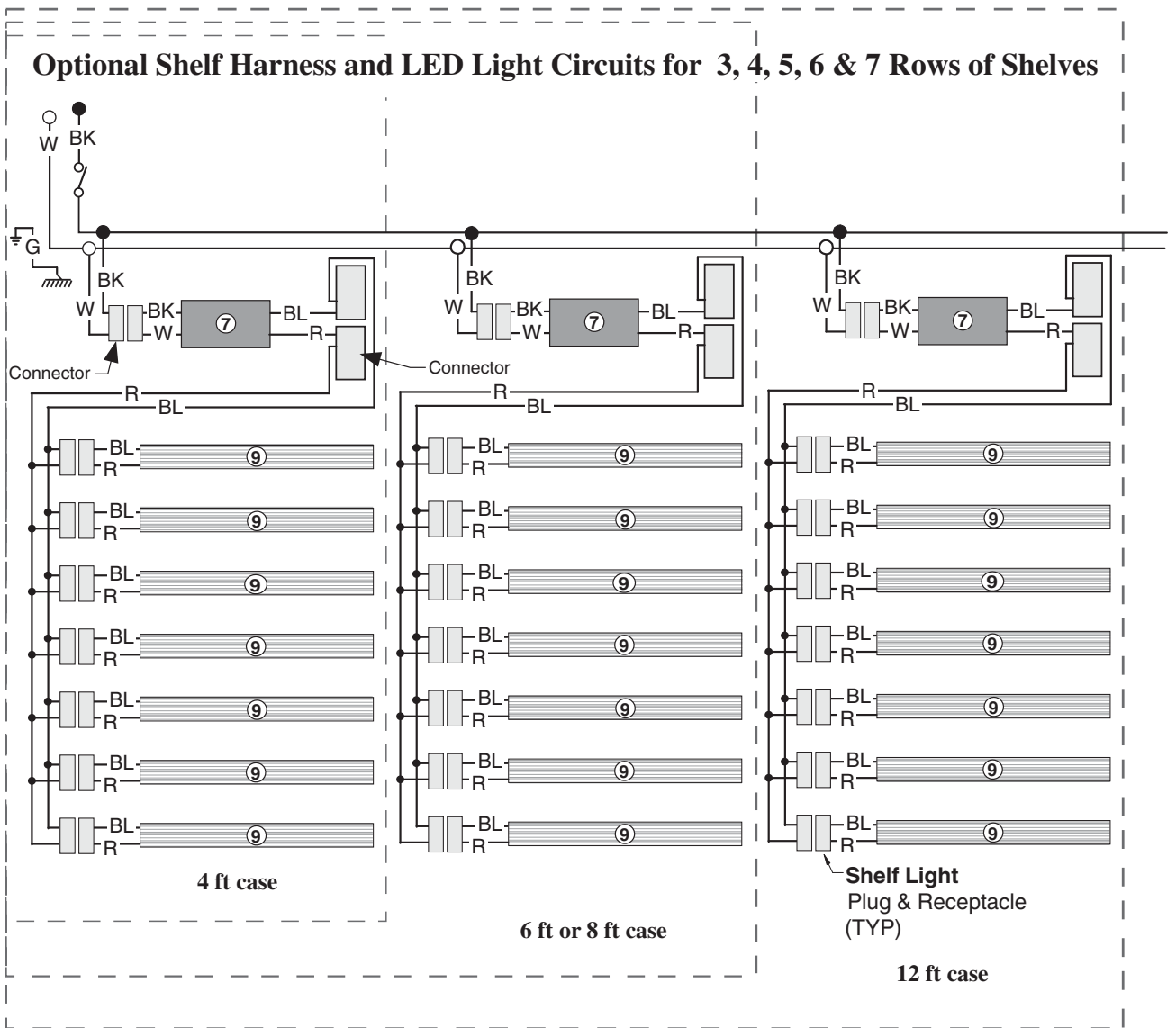

WARNING

All components must have mechanical ground, and the merchandiser must be grounded.

CIRCLED NUMBERS = PARTS LIST ITEM NUMBERS

R = Red	G = Green	BL = Blue	BK = Black	W = White
● = 120V POWER	○ = 120V NEUTRAL	⏏ = FIELD GROUND	mm = CASE GROUND	

Optional Shelf Lighting LED Fixtures

Optional Shelf Harness and LED Light Circuits for Two Rows of Shelves

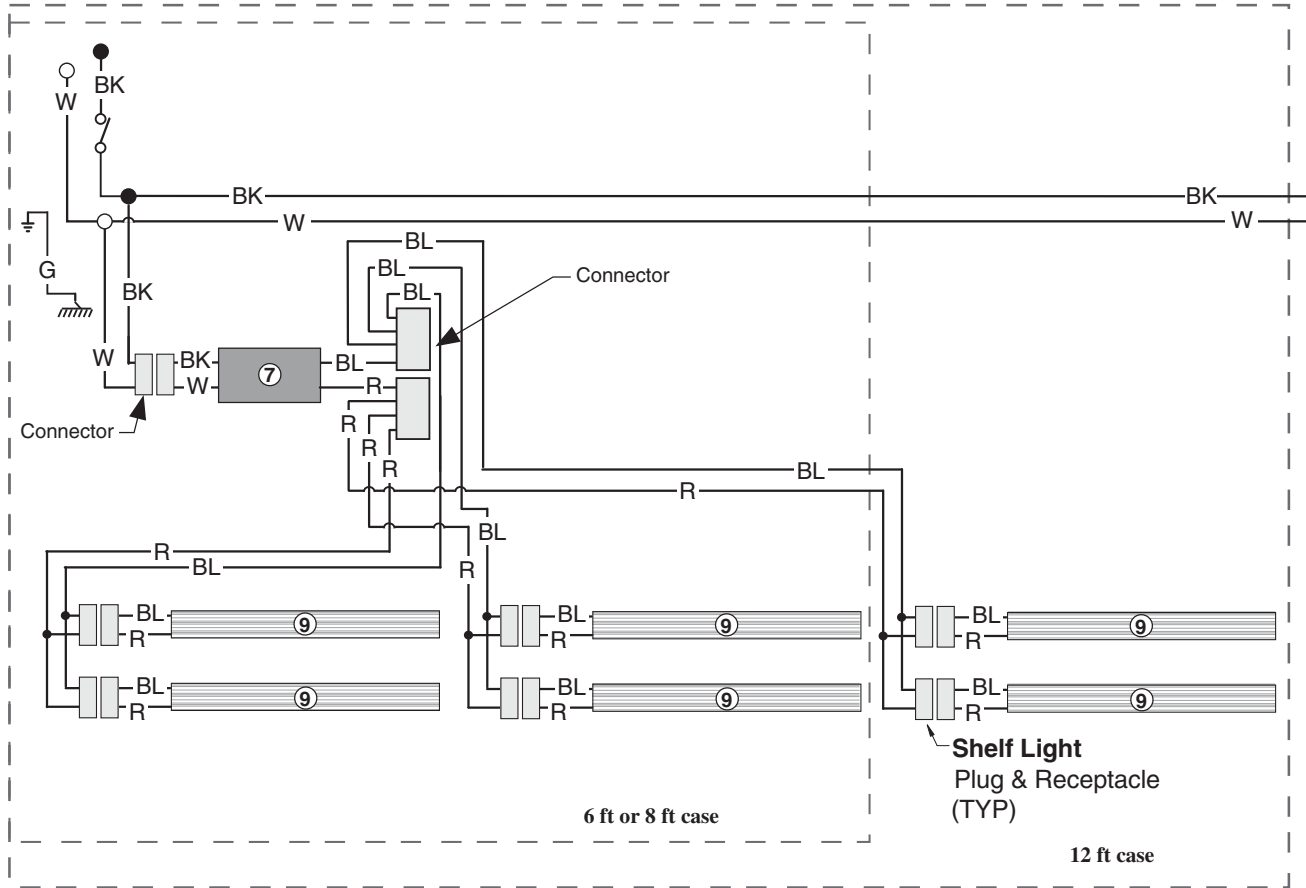

WARNING

All components must have mechanical ground, and the merchandiser must be grounded.

CIRCLED NUMBERS = PARTS LIST ITEM NUMBERS

R = Red G = Green BL = Blue BK = Black W = White
 ● = 120V POWER ○ = 120V NEUTRAL ⊥ = FIELD GROUND mm = CASE GROUND

SHELF CONFIGURATION

This case is designed for three (3) shelves.

The depth of the shelves used are critical to case performance.

The use of peg shelves is NOT recommended on C3X-LGE cases. Depth and angle requirements are listed below.

Top Shelf

Shelf Depth	Shelf Angle
12 inches	0°,10°,15°,30°,45°
14 inches	30°,45°

Second Shelf

Shelf Depth	Shelf Angle
14 inches	0°,10°,15°,30°,45°
16 inches	30°,45°

Third Shelf

Shelf Depth	Shelf Angle
16 inches	0°,10°,15°,30°,45°
18 inches	30°,45°

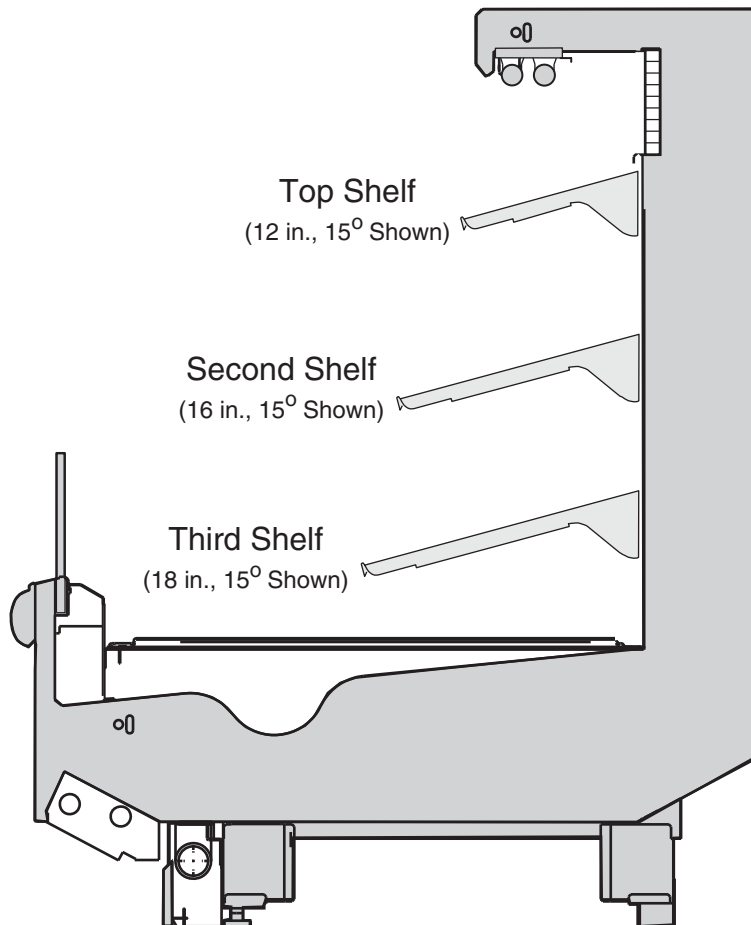

Impact Excel C3X-LGE
Dairy/Delicatessen
Precut & Packaged Produce

The ballast for the canopy and shelf lamps is located behind the canopy on the left-hand end (when facing case) of the merchandiser.

To access the ballast:

1. Remove screws at bottom edge of canopy and rear of light channel.
2. Lower light channel which will pivot on hinge.
3. Service or replace ballasts as required.
4. Reassemble items as they were originally installed.

NOTE: Rail lamp ballast is located in the electrical raceway.

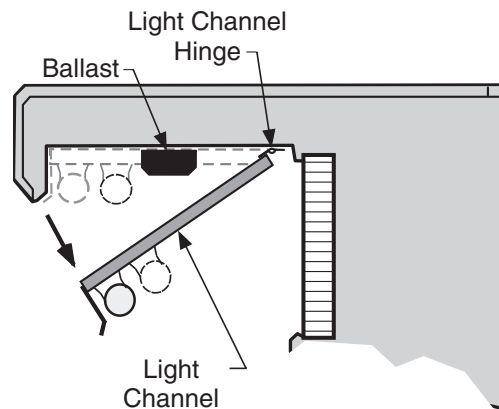
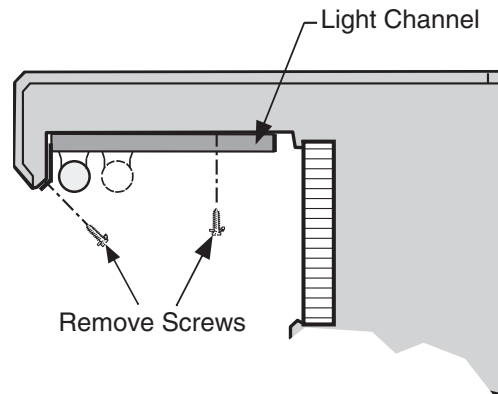

CANOPY ANTI-SWEAT HEATER

The canopy anti-sweat heater location is shown below. Connections are in the electrical wireway.

