

# HUSSMANN<sup>®</sup> Excel



## C6X-EP

Technical Data Sheet

P/N 0480158\_P

NSF<sup>®</sup> Certified

July 2019

**DOE 2017**  
Energy Efficiency  
Compliant

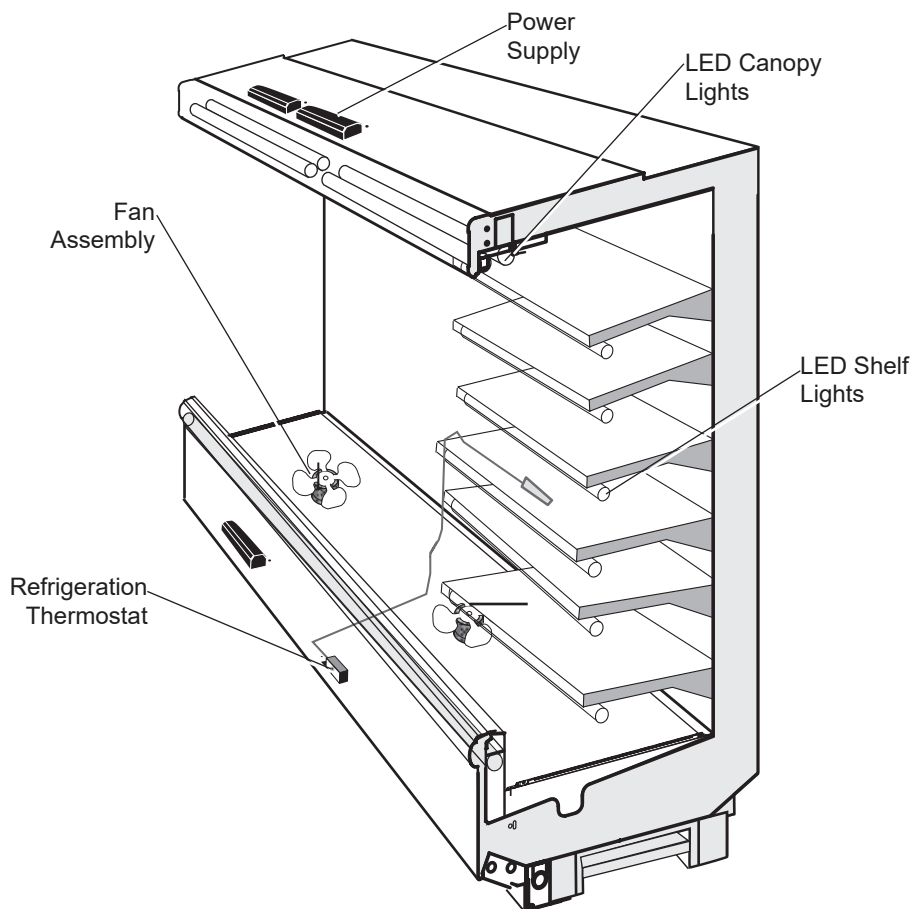

### NSF Certification

This merchandiser model is manufactured to meet NSF/ANSI (National Sanitation Foundation) Standard #7 requirements for construction, materials and cleanability.



Scan the QR code on your mobile device to access additional product information or order parts.

Parts may also be ordered at:

[parts.hussmann.com](http://parts.hussmann.com)

Call toll free: 1.855.487.7778

We reserve the right to change or revise specifications and product design in connection with any feature of our products. Such changes do not entitle the buyer to corresponding changes, improvements, additions or replacements for equipment previously sold or shipped.

Note: Revision P: July 2019. Updated Lighting and CaseShieldPTM.

Data sheet-Excel-C6X-EP

# Engineering Plan Views

| PHYSICAL DATA                   |       |
|---------------------------------|-------|
| Merchandiser Drip Pipe (in.)    | 1 1/4 |
| Merchandiser Liquid Line (in.)  | 3/8   |
| Merchandiser Suction Line (in.) | 7/8   |

## Convertible

Dimensions shown as in. and (mm).



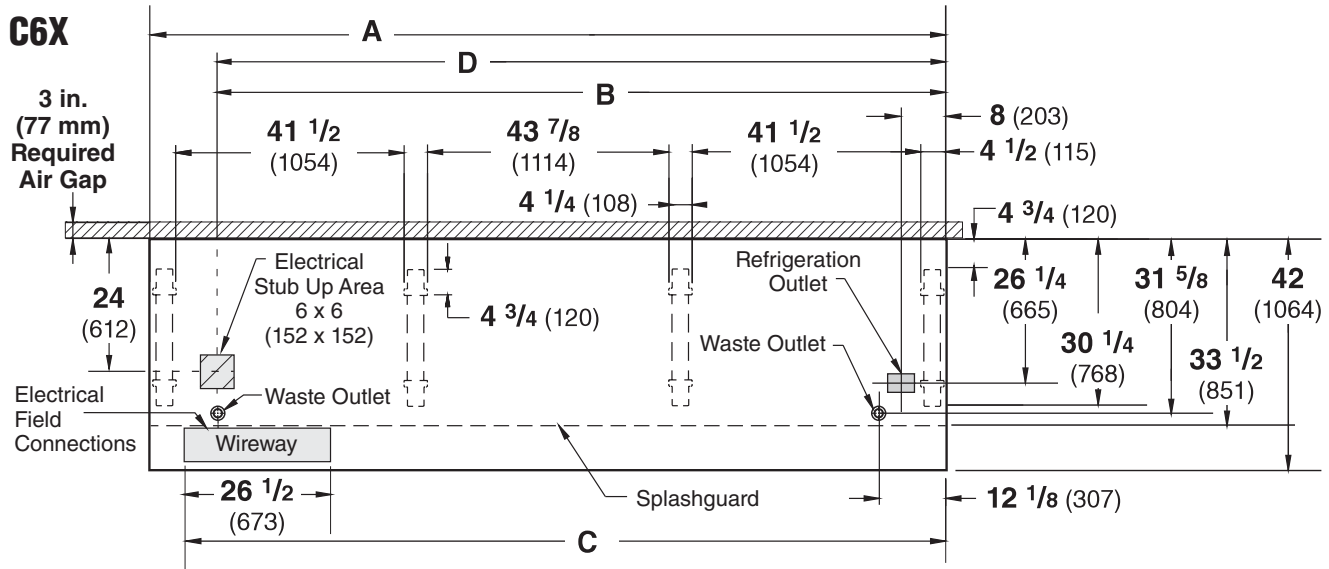

09-2005

**C6X**



**NOTE: Case-to-Case Electrical Connections are made IN FRONT OF SPLASHGUARD.**

**FRONT**

|   | 4 ft          | 6 ft          | 8 ft          | 12 ft          |
|---|---------------|---------------|---------------|----------------|
| <b>General</b>  |               |               |               |                |
| <b>(A) Case Length</b> <i>(without ends or partitions)</i><br><i>(Each end and insulated partition adds 1 1/2 in. (38 mm) to case line up.)</i>                 | 48 3/8 (1229) | 72 3/8 (1838) | 96 3/8 (2448) | 144 1/2 (3670) |
| Maximum O/S dimension of case back to front<br><i>(includes bumper)</i>   | 42 (1064)     | 42 (1064)     | 42 (1064)     | 42 (1064)      |
| Back of case to front of splashguard  | 33 1/2 (851)  | 33 1/2 (851)  | 33 1/2 (851)  | 33 1/2 (851)   |
| Back of case to O/S edge of front leg   | 30 1/4 (768)  | 30 1/4 (768)  | 30 1/4 (768)  | 30 1/4 (768)   |
| Distance between edges of external legs and center legs   | NA            | 29 1/2 (750)  | 41 1/2 (1054) | 41 1/2 (1054)  |
| Distance between edges of center legs   | NA            | NA            | NA            | 43 7/8 (1114)  |
| Distance between front legs and splashguard   | 2 3/4 (70)    | 2 3/4 (70)    | 2 3/4 (70)    | 2 3/4 (70)     |
| <b>Electrical Service</b>  <i>(Electrical Field Wiring connection point)</i> |               |               |               |                |
| <b>(B) RH End of case to center of stub up area</b>   | 36 1/4 (921)  | 60 1/4 (1530) | 84 1/4 (2140) | 132 3/8 (3363) |
| Back of case to center of stub up area  | 24 (612)      | 24 (612)      | 24 (612)      | 24 (612)       |
| Length of electrical wireway   | 26 1/2 (673)  | 26 1/2 (673)  | 26 1/2 (673)  | 26 1/2 (673)   |
| <b>(C) RH End of case to LH end of wireway</b>  | 42 1/8 (1070) | 66 1/8 (1680) | 90 1/8 (2289) | 138 1/4 (3511) |
| <b>Waste Outlets</b> <i>(One each end)</i>                                   |               |               |               |                |
| <b>(D) RH End of case to the center of LH waste outlet</b>  | 36 1/4 (921)  | 60 1/4 (1530) | 84 1/4 (2140) | 132 3/8 (3363) |
| RH End of case to the center of RH waste outlet   | 12 1/8 (307)  | 12 1/8 (307)  | 12 1/8 (307)  | 12 1/8 (307)   |
| Back O/S of case to center of waste outlets   | 31 5/8 (804)  | 31 5/8 (804)  | 31 5/8 (804)  | 31 5/8 (804)   |
| Schedule 40 PVC drip pipe   | 1 1/4 (32)    | 1 1/4 (32)    | 1 1/4 (32)    | 1 1/4 (32)     |
| <b>Refrigeration Outlet</b>    |               |               |               |                |
| Back of case to center of refrigeration outlet  | 26 1/4 (665)  | 26 1/4 (665)  | 26 1/4 (665)  | 26 1/4 (665)   |
| RH end of case to center of refrigeration outlet  | 8 (203)       | 8 (203)       | 8 (203)       | 8 (203)        |

Multi-deck, 6 Display Levels



Hussmann refrigerated merchandisers configured for sale for use in the United States meet or surpass the requirements of the DOE 2017 energy efficiency standards.

**Excel C6X-EP**  
**Dairy/Delicatessen/Produce**

Dimensions shown as in. and (mm).

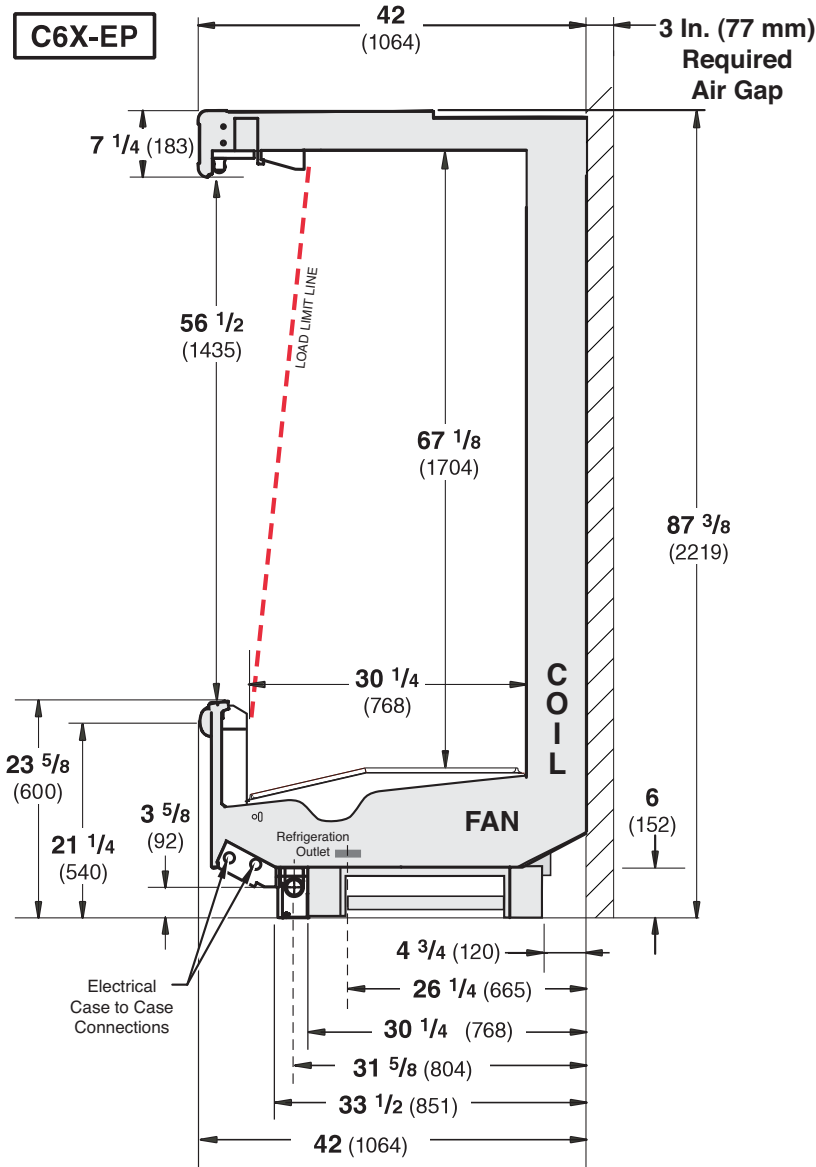

**REFRIGERATION DATA**

Note: This data is based on store temperature and humidity that does not exceed 75°F and 55% R.H.

| C6X-EP§            | DAIRY/DELI/PRODUCE† |     |
|--------------------|---------------------|-----|
|                    | UNLIT               | LIT |
| Discharge Air (°F) | 33                  | 31  |
| Evaporator (°F)    | 28                  | 26  |
| Unit Sizing (°F)   | 26                  | 24  |

†For red meat application, lower evaporator temperature and unit sizing 3°F. Increase Btu 5%.  
§ Average evaporator temperature shown. Use dew point for high glide refrigerants for unit sizing. Care should be taken to use the dew point in PT tables for measuring and adjusting superheat. Adjust evaporator pressure as needed to maintain discharge air temperature shown.

| C6X-EP       | Dairy/Deli/Produce |      |
|--------------|--------------------|------|
|              | 4 ft/8 ft/12 ft    | 6 ft |
| PARALLEL     | 1359               | 1387 |
| CONVENTIONAL | 1419               | 1447 |

‡ Add 10 Btu/hr/ft per shelf row for LED fixtures. Add 20 Btu/hr/ft per shelf row for fluorescent lamps. Reduce refrigeration load by 15% if fitted with CaseShieldPTM.

**DEFROST DATA**

|                           | C6X-EP |
|---------------------------|--------|
| Frequency Hr              | 12     |
| Defrost Water (lb/ft/day) | 10.5   |

(± 15% based on case configuration and product loading).

|                 | C6X-EP          |
|-----------------|-----------------|
| OFFTIME         |                 |
| TIME (minutes)  | 30              |
| ELECTRIC OR GAS | Not Recommended |

**CONVENTIONAL CONTROLS**

| Low Pressure Backup Control |                      |
|-----------------------------|----------------------|
| CI/CO*                      |                      |
| C6X-EP                      | DAIRY/DELI/PRODUCE†† |
| Temp (°F)                   | 19°F / 9°F           |

| Indoor Unit Only, Pressure Defrost |      |
|------------------------------------|------|
| Termination*                       | 48°F |

\*Use a Temperature Pressure Chart to determine PSIG conversions.  
††For red meat application, reduce low pressure backup control by 3°F.

| Estimated Charge ** |        | C6X-EP |        |
|---------------------|--------|--------|--------|
| 4 ft                | 1.9 lb | 30 oz  | 0.9 kg |
| 6 ft                | 2.6 lb | 42 oz  | 1.2 kg |
| 8 ft                | 3.7 lb | 59 oz  | 1.7 kg |
| 12 ft               | 5.1 lb | 82 oz  | 2.3 kg |

\*\*This is an average for all refrigerant types. Actual refrigerant charge may vary by approximately half a pound (8 oz/0.2 kg).

# Excel C6X-EP

## Dairy/Delicatessen/Produce

### Electrical Data

|                    | 4 ft | 6 ft | 8 ft | 12 ft |
|--------------------|------|------|------|-------|
| Number of Fans—25W | 1    | —    | 2    | 3     |
| Number of Fans—7W  | —    | 4    | —    | —     |

| Evaporator Fan                         | Amperes |      |      |       | Watts |      |      |       |
|--|---------|------|------|-------|-------|------|------|-------|
|  | 4 ft    | 6 ft | 8 ft | 12 ft | 4 ft  | 6 ft | 8 ft | 12 ft |
| 120V 50/60Hz Standard Energy Efficient | 0.60    | 0.76 | 1.20 | 1.80  | 36    | 56   | 72   | 108   |
| 230V 50/60Hz Standard Energy Efficient | 0.30    | 0.40 | 0.60 | 0.90  | 36    | 56   | 72   | 108   |
| 230V 60Hz Export                       | 0.66    | 1.00 | 1.32 | 1.98  | 100   | 156  | 200  | 300   |
| 230V 50Hz Export                       | 0.76    | 1.12 | 1.52 | 2.28  | 114   | 168  | 228  | 342   |

### Minimum Circuit Ampacity

|  |      |      |      |      |
|--|------|------|------|------|
| 120V 50/60Hz Standard Energy Efficient | 0.80 | 0.96 | 1.40 | 2.00 |
| 230V 50/60Hz Standard Energy Efficient | 0.50 | 0.60 | 0.80 | 1.10 |
| 230V 60Hz Export                       | 0.86 | 1.20 | 1.52 | 2.18 |
| 230V 50Hz Export                       | 0.96 | 1.32 | 1.72 | 2.48 |

### Maximum Over Current Protection 120V

|                                      |    |    |    |    |
|--------------------------------------|----|----|----|----|
| Maximum Over Current Protection 120V | 20 | 20 | 20 | 20 |
| Maximum Over Current Protection 230V | 15 | 15 | 15 | 15 |

ONLY LIGHTING CONFIGURATIONS THAT ARE COMPLIANT WITH THE U.S. DEPT. OF ENERGY (DOE) 2017 REGULATION ARE AVAILABLE FOR SALE FOR USE IN THE U.S.A.

| LED LIGHTING  | Amperes |      |      |       | Watts |      |      |       |
|---|---------|------|------|-------|-------|------|------|-------|
|   | 4 ft    | 6ft  | 8 ft | 12 ft | 4 ft  | 6 ft | 8 ft | 12 ft |
| <b>EcoShine ULTRA Canopy Lights</b>                     |         |      |      |       |       |      |      |       |
| 1 Row EcoShine ULTRA                                    | 0.16    | 0.26 | 0.36 | 0.54  | 19    | 31   | 43   | 64    |
| <b>EcoShine II Canopy Lights</b>                        |         |      |      |       |       |      |      |       |
| 1 Row EcoShine II                                       | 0.16    | 0.26 | 0.32 | 0.48  | 19    | 32   | 39   | 58    |
| 1 Row EcoShine II HO                                    | 0.22    | 0.33 | 0.44 | 0.66  | 27    | 40   | 53   | 79    |
| <b>EcoShine II Shelf Lights</b>                         |         |      |      |       |       |      |      |       |
| 2 Rows of Shelves                                       | 0.16    | 0.23 | 0.33 | 0.49  | 20    | 28   | 40   | 59    |
| 3 Rows of Shelves                                       | 0.25    | 0.35 | 0.49 | 0.74  | 30    | 42   | 59   | 89    |
| 4 Rows of Shelves                                       | 0.33    | 0.47 | 0.66 | 0.99  | 40    | 56   | 79   | 119   |
| 5 Rows of Shelves                                       | 0.41    | 0.59 | 0.82 | 1.24  | 49    | 71   | 99   | 148   |
| 6 Rows of Shelves                                       | 0.49    | 0.70 | 0.99 | 1.48  | 59    | 85   | 119  | 178   |
| <b>EcoShine II Rail Light — 1 Row</b>                   | 0.08    | 0.12 | 0.16 | 0.25  | 10    | 14   | 20   | 30    |
| <b>Standard Lighting (T-8 Fluorescent) 1 Row Canopy</b> |         |      |      |       |       |      |      |       |
| Each Row of Canopy, Shelf or Rail Lights                | 0.26    | 0.51 | 0.51 | 0.77  | 30    | 59   | 59   | 85    |

120V Lighting Circuit Total = Standard Lighting + Total Optional Lighting + Optional Shelf Lighting

120V LED Lighting Circuit Total = Canopy Lighting + Shelf Lighting

230V Lighting Circuit Total = Multiply 120V Lighting Circuit Total by 0.52

Please note: some combinations of fluorescent lights on this case model may not be compliant with DOE 2017 and may not be available to order in the US and Canada. More lighting options are available with LED lights. The Hussmann Product Configurator will not allow lighting options that do not comply with the DOE 2017 standards.

**Excel C6X-EP**  
**Dairy/Delicatessen/Produce**

**Product Data**

|  |  |
|--|--|
| <i>Recommended Usable Cube</i> <sup>1</sup> (Cu Ft/Ft) | 9.79 ft <sup>3</sup> /ft (0.91 m <sup>3</sup> /m)  |
| <i>AHRI Total Display Area</i> <sup>2</sup> (Sq Ft/Ft) | 4.72 ft <sup>2</sup> /ft (1.44 m <sup>2</sup> /m)  |
| <i>Shelf Area</i> <sup>3</sup> (Sq Ft/Ft)              | 11.73 ft <sup>2</sup> /ft (3.58 m <sup>2</sup> /m) |

- <sup>1</sup> AHRI Refrigerated Volume less shelving and other unusable space: Refrigerated Volume/Unit of Length, ft<sup>3</sup>/ft [m<sup>3</sup>/m]
- <sup>2</sup> Computed using AHRI 1200 standard methodology: Total Display Area, ft<sup>2</sup> [m<sup>2</sup>]/Unit of Length, ft [m]
- <sup>3</sup> Shelf surface area is composed of bottom deck plus standard shelf complement, as shown in the Hussmann *Product Reference Guide*. The standard shelf complement for this model is (5) rows of 22-inch shelves.

| ESTIMATED SHIPPING WEIGHT <sup>4</sup> |           |            |            |            |                     |
|--|-----------|------------|------------|------------|---------------------|
| Case                                   | 4 ft      | 6 ft       | 8 ft       | 12 ft      | Solid End<br>(each) |
| <b>lb (kg)</b>                         | 600 (272) | 1000 (454) | 1200 (544) | 1900 (862) | 100 (45)            |

<sup>4</sup> Actual weights will vary according to optional kits included.

**Fan Wiring**  
**Offtime Defrost**

**1, 2, 3 & 4 Fans**

- 4 ft – 1 Fan
- 6 ft – 4 Fans
- 8 ft – 2 Fans
- 12 ft – 3 Fans

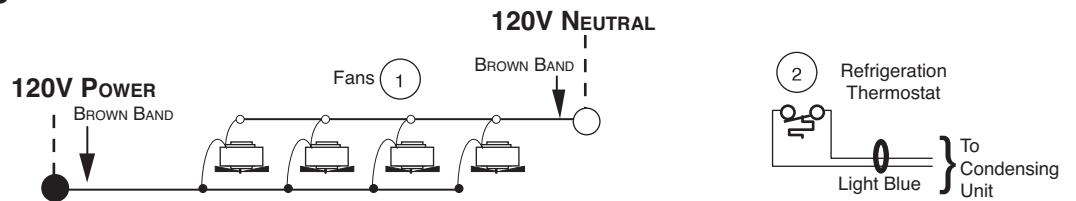

Scan QR code to access  
Fluorescent Wiring Diagrams  
on your mobile device

# LED Canopy and Rail Light Circuits

## LED Canopy Lighting - 1 Row

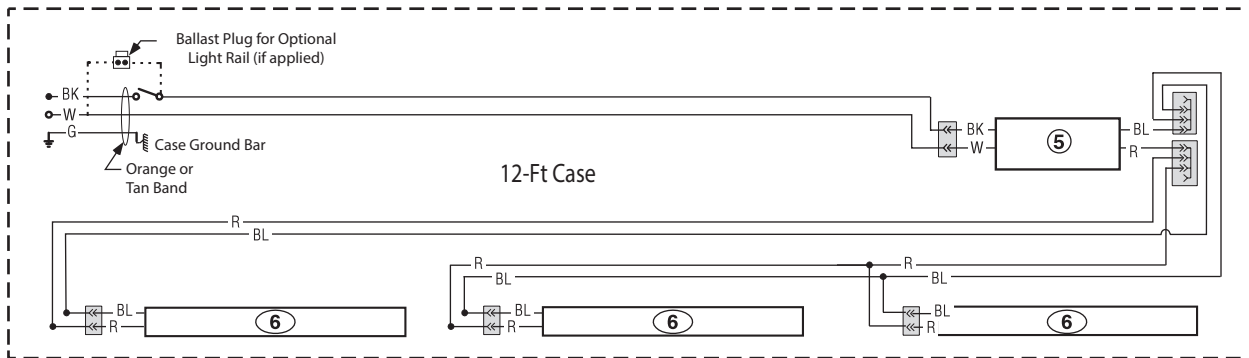
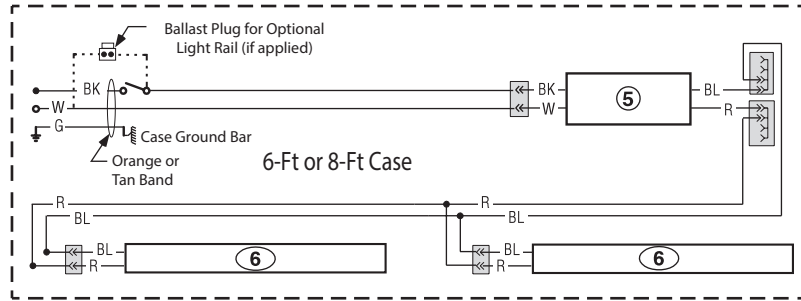
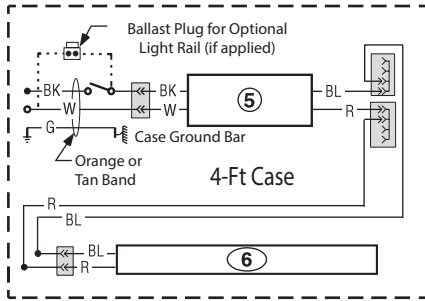

## LED Rail Lighting - 1 Row

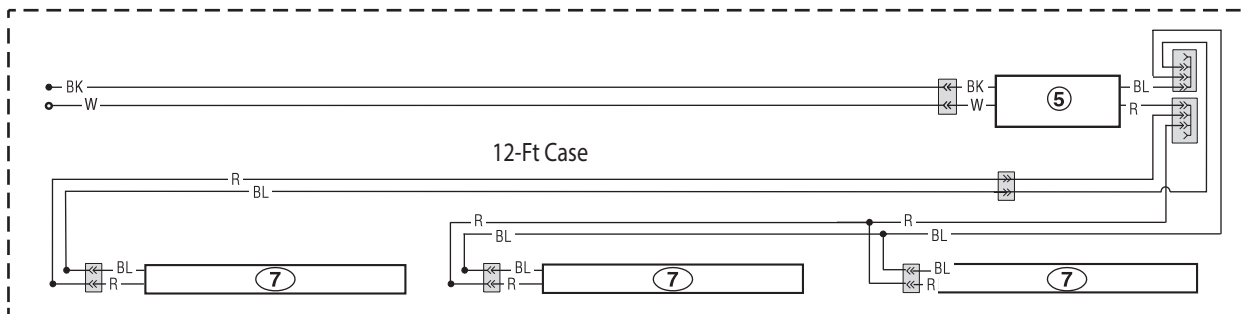
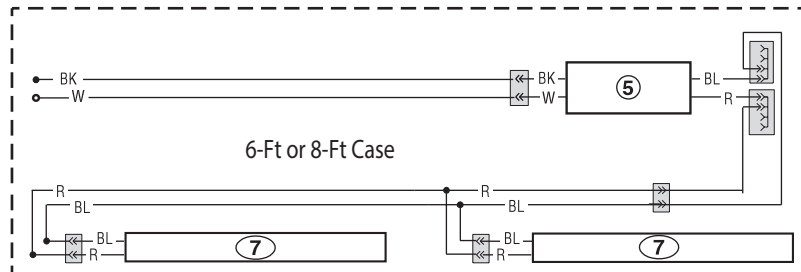
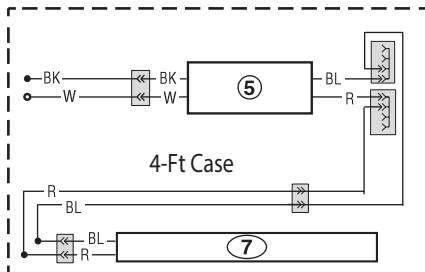

### WARNING

All components must have mechanical ground, and the merchandiser must be grounded.

CIRCLED NUMBERS = PARTS LIST ITEM NUMBERS

R = Red    Y = Yellow    G = Green    BL = Blue    BK = Black    W = White  
 ● = 120V POWER    ○ = 120V NEUTRAL    ⊥ = FIELD GROUND    ≡ = CASE GROUND

## Optional Shelf Lighting LED Fixtures

### Shelf Harness and LED Light Circuits for 4 or 5 Rows of Shelves

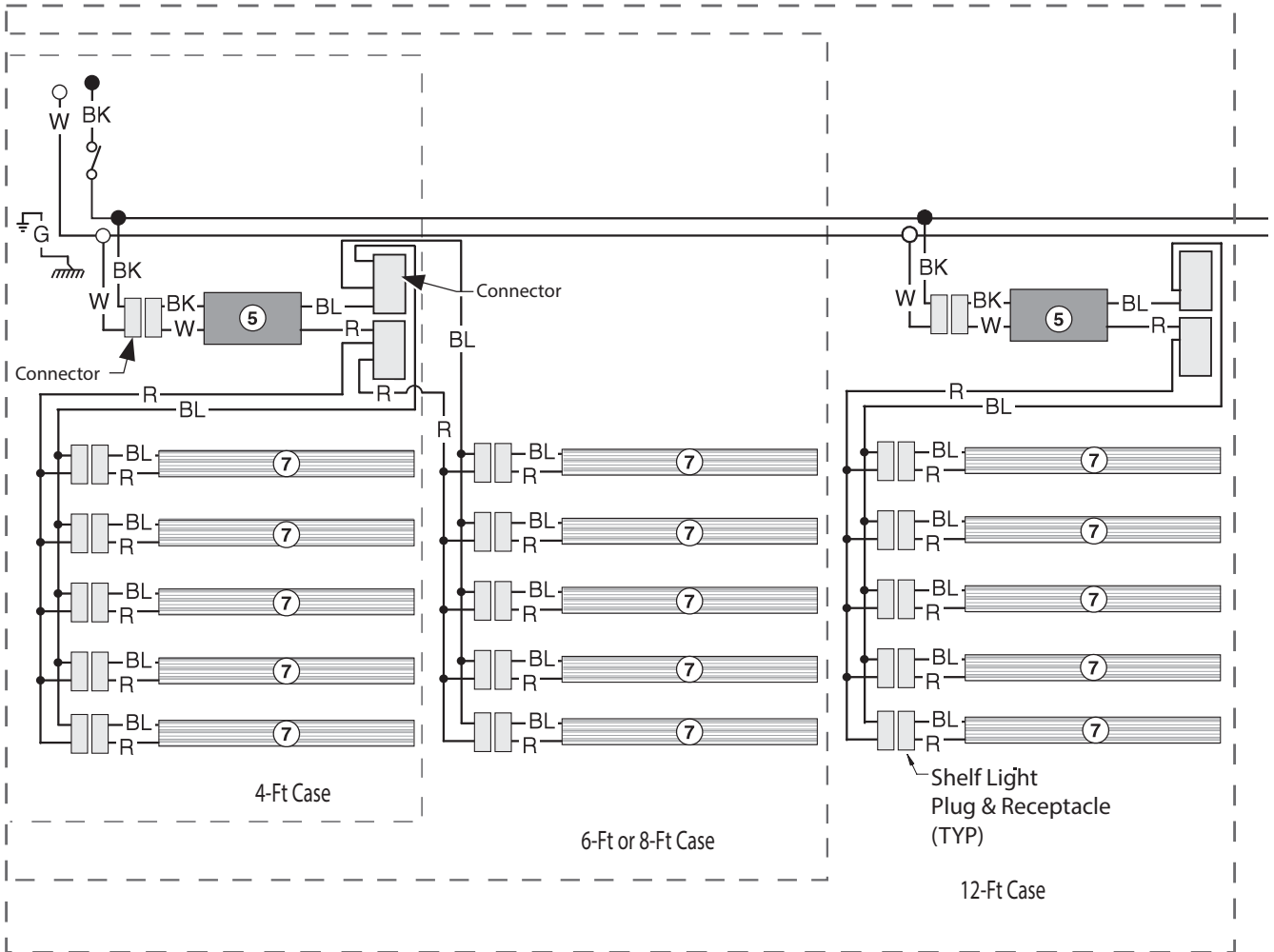

#### WARNING

All components must have mechanical ground, and the merchandiser must be grounded.

CIRCLED NUMBERS = PARTS LIST ITEM NUMBERS

R = Red    G = Green    BL = Blue    BK = Black    W = White

● = 70V POWER

○ = 70V NEUTRAL

⊥ = FIELD GROUND

⏏ = CASE GROUND

# Optional Shelf Lighting LED Fixtures

## Shelf Harness and LED Light Circuits for 6 Rows of Shelves

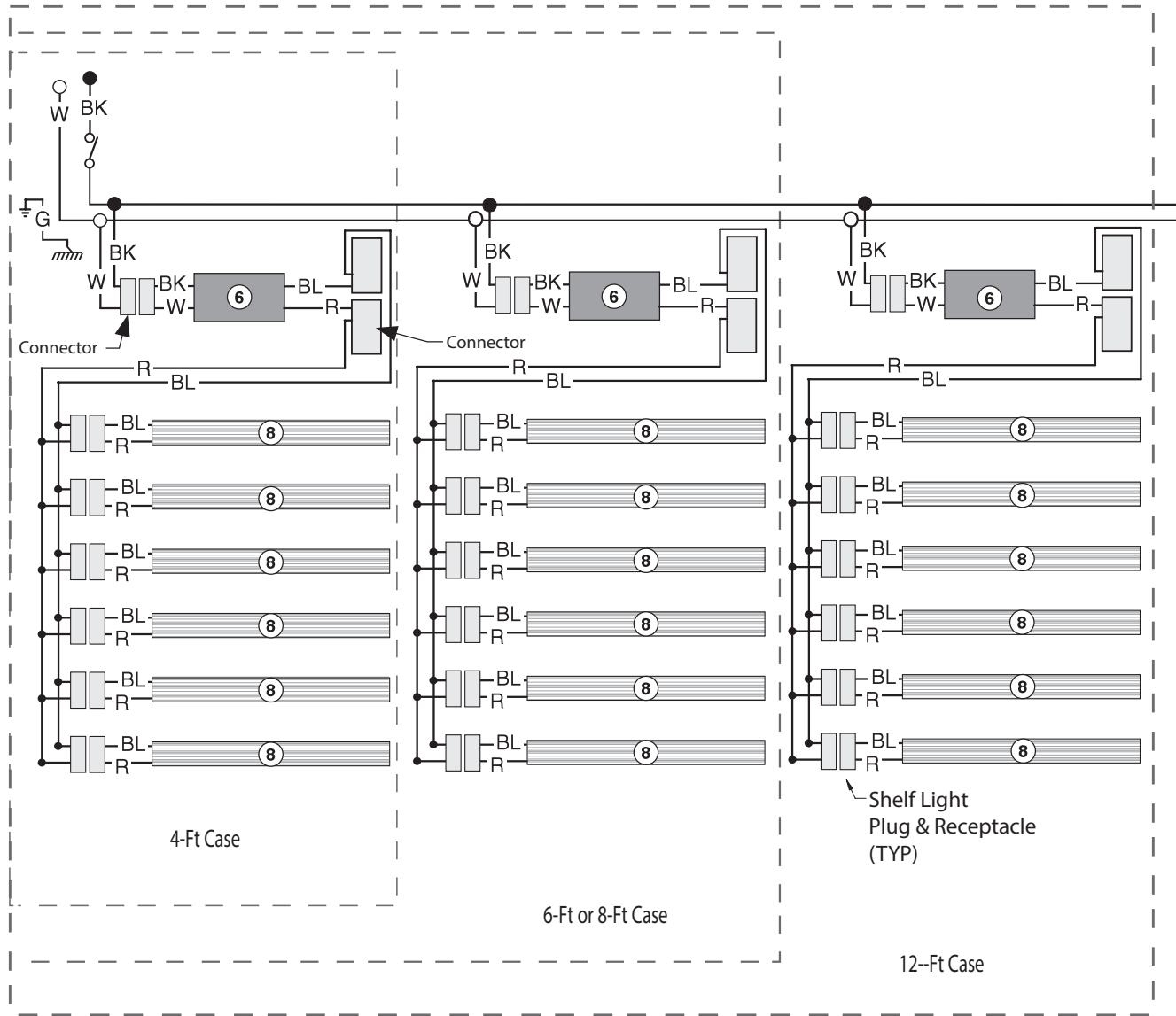

### WARNING

All components must have mechanical ground, and the merchandiser must be grounded.

CIRCLED NUMBERS = PARTS LIST ITEM NUMBERS

R = Red    G = Green    BL = Blue    BK = Black    W = White

● = 80V POWER

○ = 80V NEUTRAL

⏏ = FIELD GROUND

⏏ = CASE GROUND