

HUSSMANN[®] *Excel*



C6X-LRE

Technical Data Sheet
P/N 0480223_N
NSF[®] Certified

July 2019

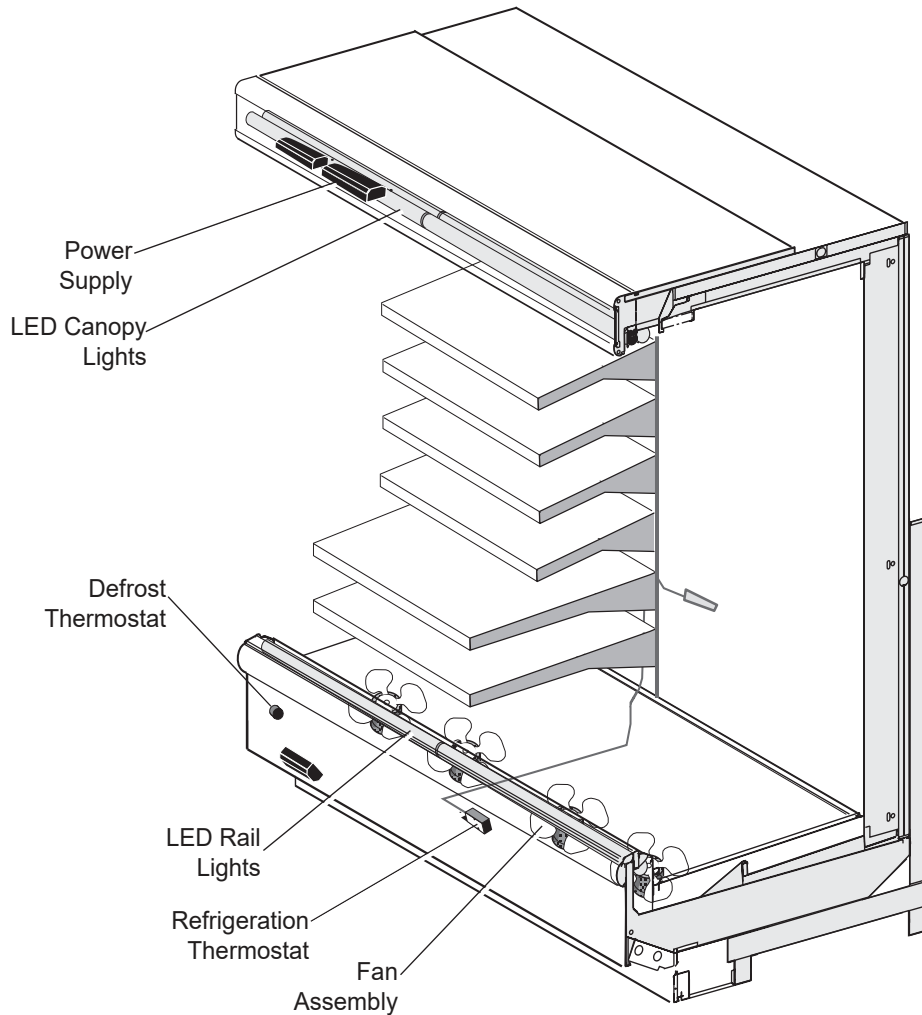

DOE 2017
Energy Efficiency
Compliant

**LIGHTED SHELVES
NOT RECOMMENDED**

NSF Certification

This merchandiser model is manufactured to meet NSF/ANSI (National Sanitation Foundation) Standard #7 requirements for construction, materials and cleanability.



Scan the QR code on your mobile device to access additional product information or order parts.

Parts may also be ordered at:

parts.hussmann.com

Call toll free: 1.855.487.7778

We reserve the right to change or revise specifications and product design in connection with any feature of our products. Such changes do not entitle the buyer to corresponding changes, improvements, additions or replacements for equipment previously sold or shipped.

Note: Revision N: July 2019. Updated Lighting and CaseShieldPTM.

Datasheet-Excel-C6X-LRE

Engineering Plan Views

PHYSICAL DATA	
Merchandiser Drip Pipe (in.)	1 1/4
Merchandiser Liquid Line (in.)	3/8
Merchandiser Suction Line (in.)	7/8

Rear Load
Dairy &
Delicatessen
09-2005

C6X-R

Dimensions shown as in. and (mm).

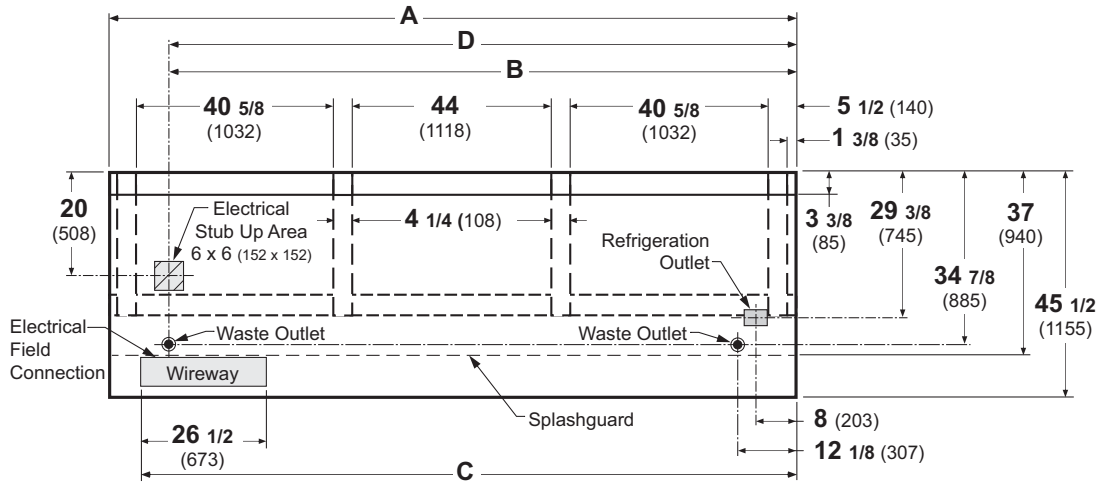

NOTE: Case-to-Case Electrical Connections are made IN FRONT OF SPLASHGUARD.

FRONT

The EXCEL Rear Load Convertible model is not offered in 4-ft or 6-ft length.

General

(A) Case Length (without ends or partitions)

(Each end and insulated partition adds 1 1/2 in. (38 mm) to case line up.)

Maximum O/S dimension of case back to front

(includes bumper)

Back of case to front of splashguard

Back of case to O/S edge of front skid rail

Width of skid rail

RH end of case to outside edge of external support

Distance between front skid rail and splashguard

Distance between edges of external supports

Distance between edges of

external support and center support

Distance between edges of center supports

Electrical Service (Electrical Field Wiring connection point)

(B) RH End of case to center of stub up area

Back of case to center of stub up area

Length of electrical wireway 

(C) RH End of case to LH end of wireway

Waste Outlets (One each end)

(D) RH End of case to the center of LH waste outlet

RH End of case to the center of RH waste outlet

Back O/S of case to center of waste outlets

Schedule 40 PVC drip pipe

Refrigeration Outlet

Back of case to center of refrigeration outlet

RH end of case to center of refrigeration outlet

	8 ft	12 ft
(A) Case Length (without ends or partitions)	96 3/8 (2448)	144 1/2 (3670)
Maximum O/S dimension of case back to front (includes bumper)	45 1/2 (1150)	45 1/2 (1150)
Back of case to front of splashguard	36 7/8 (937)	36 7/8 (937)
Back of case to O/S edge of front skid rail	28 1/4 (717)	28 1/4 (717)
Width of skid rail	3 1/4 (82)	3 1/4 (82)
RH end of case to outside edge of external support	5 1/2 (140)	5 1/2 (140)
Distance between front skid rail and splashguard	7 1/8 (181)	7 1/8 (181)
Distance between edges of external supports	42 1/2 (1070)	42 1/2 (1070)
Distance between edges of external support and center support	NA	46 (1168)
Distance between edges of center supports	NA	46 (1168)
(B) RH End of case to center of stub up area	84 1/4 (2140)	132 3/8 (3363)
Back of case to center of stub up area	20 (508)	20 (508)
Length of electrical wireway	26 1/2 (673)	26 1/2 (673)
(C) RH End of case to LH end of wireway	90 1/8 (2289)	138 1/4 (3511)
(D) RH End of case to the center of LH waste outlet	84 1/4 (2140)	132 3/8 (3363)
RH End of case to the center of RH waste outlet	12 (305)	12 (305)
Back O/S of case to center of waste outlets	34 7/8 (885)	34 7/8 (885)
Schedule 40 PVC drip pipe	1 1/4 (32)	1 1/4 (32)
Back of case to center of refrigeration outlet	29 1/2 (749)	29 1/2 (749)
RH end of case to center of refrigeration outlet	8 (203)	8 (203)

Rear Stockable Multi-deck, 6 Display Levels, Low Front



Hussmann refrigerated merchandisers configured for sale for use in the United States meet or surpass the requirements of the DOE 2017 energy efficiency standards.

Dimensions shown as in. and (mm).

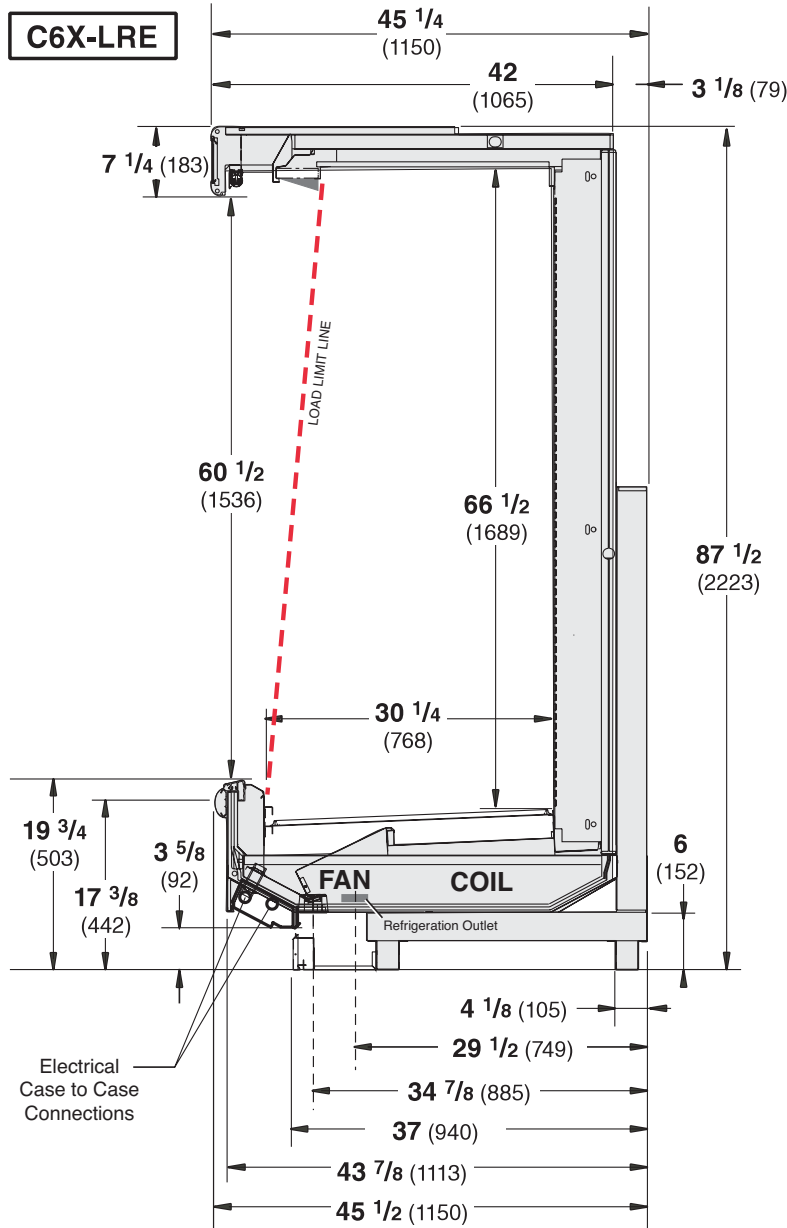

Estimated Charge **		C6X-LRE	
8 ft	3.2 lb	51 oz	1.5 kg
12 ft	4.5 lb	72 oz	2.0 kg

**This is an average for all refrigerant types. Actual refrigerant charge may vary by approximately half a pound (8 oz/0.2 kg).

Excel C6X-LRE
Dairy & Delicatessen

REFRIGERATION DATA

Note: This data is based on store temperature and humidity that does not exceed 75°F and 55% R.H.

	C6X-LRE§
Discharge Air °F	32
Evaporator °F	21
Unit Sizing °F	19

§ Average evaporator temperature shown. Use dew point for high glide refrigerants for unit sizing. Care should be taken to use the dew point in PT tables for measuring and adjusting superheat. Adjust evaporator pressure as needed to maintain discharge air temperature shown.

Btu/hr/ft — Unlit Shelves

C6X-LRE	Parallel	Conventional
UNLIT	1735	1905

Reduce refrigeration load by 15% if fitted with CaseShieldPTM.

DEFROST DATA

	C6X-LRE
Frequency Hr	6
Defrost Water (lb/ft/day)	10.50

(± 15% based on case configuration and product loading).

	C6X-LRE
OFFTIME	
Temp Term °F	48
Failsafe Minutes	35

ELECTRIC OR GAS Not Recommended

Standard Defrost Thermostat

Close on rise: close 48°F — open 33°F

CONVENTIONAL CONTROLS

Low Pressure Backup Control

CI/CO*	C6X-LRE
	14°F / 4°F

Indoor Unit Only, Pressure Defrost

Termination* 48°F

*Use a Temperature Pressure Chart to determine PSIG conversions.

Excel **C6X-LRE**

Dairy & Delicatessen

Electrical Data

The EXCEL Rear Load Convertible model is not offered in 4-ft or 6-ft length.

Number of Fans—12W	Amperes		Watts	
	8 ft	12 ft	8 ft	12 ft
	4	6		
Evaporator Fan	Amperes		Watts	
	8 ft	12 ft	8 ft	12 ft
120V 50/60Hz Standard Energy Efficient	1.20	1.80	72	108
230V 50/60Hz Standard Energy Efficient	0.60	0.90	72	108
230V 60Hz Export	1.32	1.98	200	300
230V 50Hz Export	1.52	2.28	228	342
Minimum Circuit Ampacity				
120V 50/60Hz Standard Energy Efficient	1.40	2.00		
230V 50/60Hz Standard Energy Efficient	0.80	1.10		
230V 60Hz Export	1.52	2.18		
230V 50Hz Export	1.72	2.48		
Maximum Over Current Protection 120V	20	20		
Maximum Over Current Protection 230V	15	15		

ONLY LIGHTING CONFIGURATIONS THAT ARE COMPLIANT WITH THE U.S. DEPT. OF ENERGY (DOE) 2017 REGULATION ARE AVAILABLE FOR SALE FOR USE IN THE U.S.A.

LED LIGHTING	Amperes		Watts	
	8 ft	12 ft	8 ft	12 ft
EcoShine ULTRA Canopy Lights				
1 Row EcoShine ULTRA	0.36	0.54	43	64
EcoShine II Canopy Lights				
1 Row EcoShine II	0.32	0.48	39	58
1 Row EcoShine II HO	0.44	0.66	53	79
Optional Shelf Lighting				
NOT RECOMMENDED				
EcoShine II Rail Light — 1 Row	0.16	0.25	20	30
Standard Lighting (T-8 Fluorescent) 1 Row Canopy				
Each Row of Canopy, Shelf or Rail Lights	0.51	0.77	59	85

120V Lighting Circuit Total = Standard Lighting + Total Optional Lighting + Optional Shelf Lighting

120V LED Lighting Circuit Total = Canopy Lighting + Shelf Lighting

230V Lighting Circuit Total = Multiply 120V Lighting Circuit Total by 0.52

Please note: some combinations of fluorescent lights on this case model may not be compliant with DOE 2017 and may not be available to order in the US and Canada. More lighting options are available with LED lights. The Hussmann Product Configurator will not allow lighting options that do not comply with the DOE 2017 standards.

Product Data

<i>Recommended Usable Cube</i> ¹ (Cu Ft/Ft)	10.10 ft ³ /ft (0.94 m ³ /m)
<i>AHRI Total Display Area</i> ² (Sq Ft/Ft)	5.05 ft ² /ft (1.54 m ² /m)
<i>Shelf Area</i> ³ (Sq Ft/Ft)	11.73 ft ² /ft (3.58 m ² /m)

- ¹ AHRI Refrigerated Volume less shelving and other unusable space: Refrigerated Volume/Unit of Length, ft³/ft [m³/m]
- ² Computed using AHRI 1200 standard methodology: Total Display Area, ft² [m²]/Unit of Length, ft [m]
- ³ Shelf surface area is composed of bottom deck plus standard shelf complement, as shown in the Hussmann *Product Reference Guide*. The standard shelf complement for this model is (2) rows of 16-inch shelves and (3) rows of 18-inch shelves.

ESTIMATED SHIPPING WEIGHT⁴

Case	8 ft	12 ft	Solid End
			(each)
lb (kg)	1300 (590)	1500 (680)	100 (45)

⁴ Actual weights will vary according to optional kits included.

**Fan Wiring
Offtime Defrost**

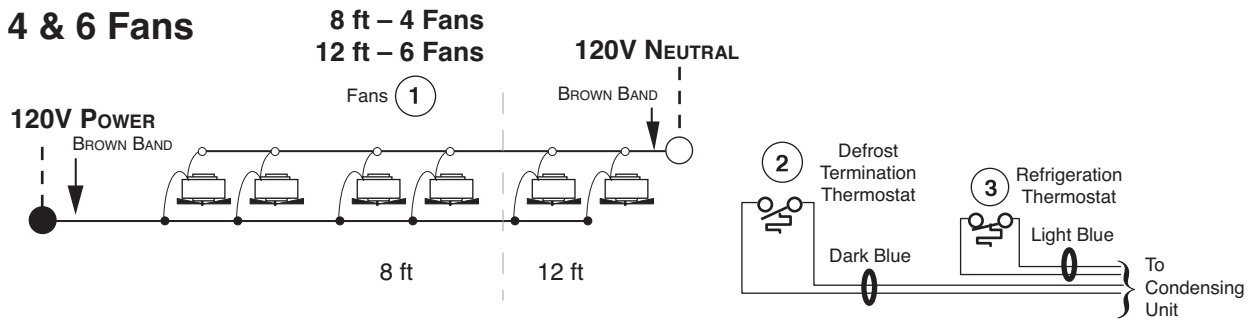

Scan QR code to access
Fluorescent Wiring Diagrams
on your mobile device.

LED Canopy and Rail Light Circuits

LED Canopy Lighting - 1 Row

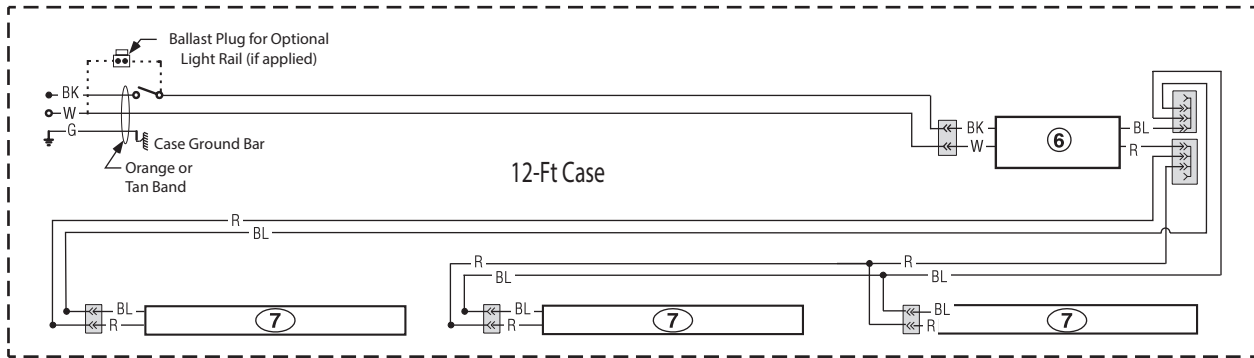
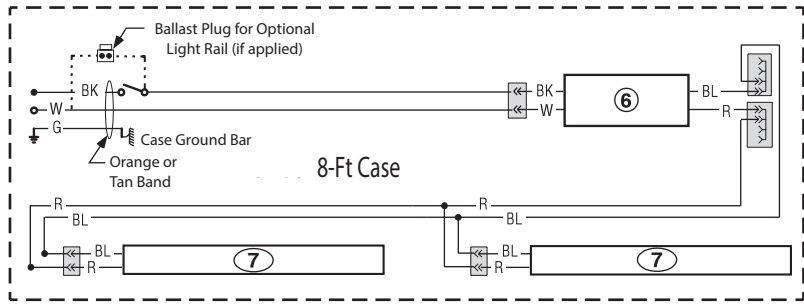

LED Rail Lighting - 1 Row

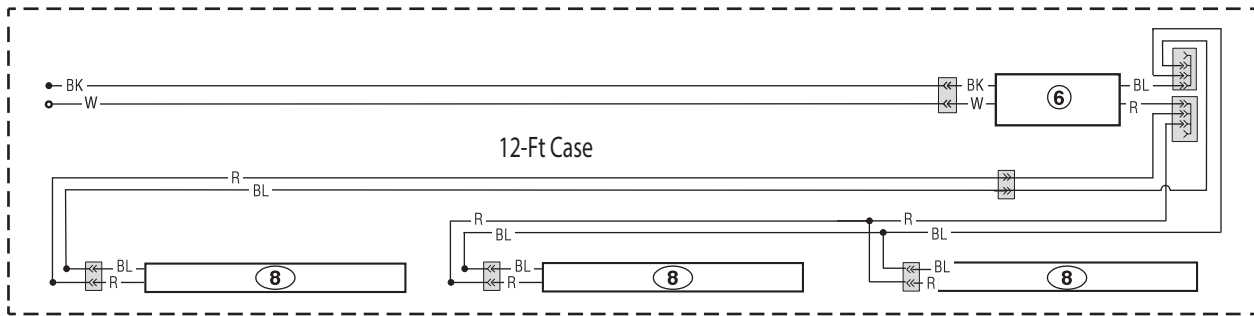
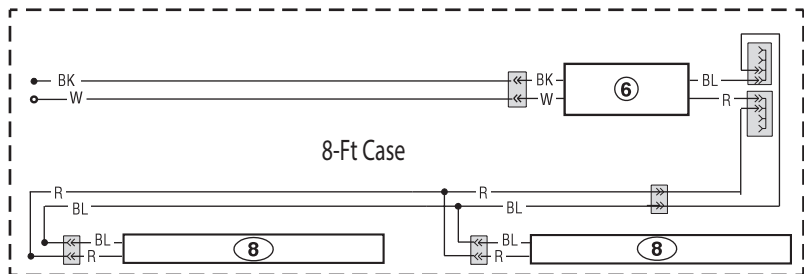

WARNING

All components must have mechanical ground, and the merchandiser must be grounded.

CIRCLED NUMBERS = PARTS LIST ITEM NUMBERS

R = Red Y = Yellow G = Green BL = Blue BK = Black W = White

● = 120V POWER ○ = 120V NEUTRAL ⏏ = FIELD GROUND ⏏ = CASE GROUND

Impact Excel **C6X-LRE**

Dairy & Delicatessen

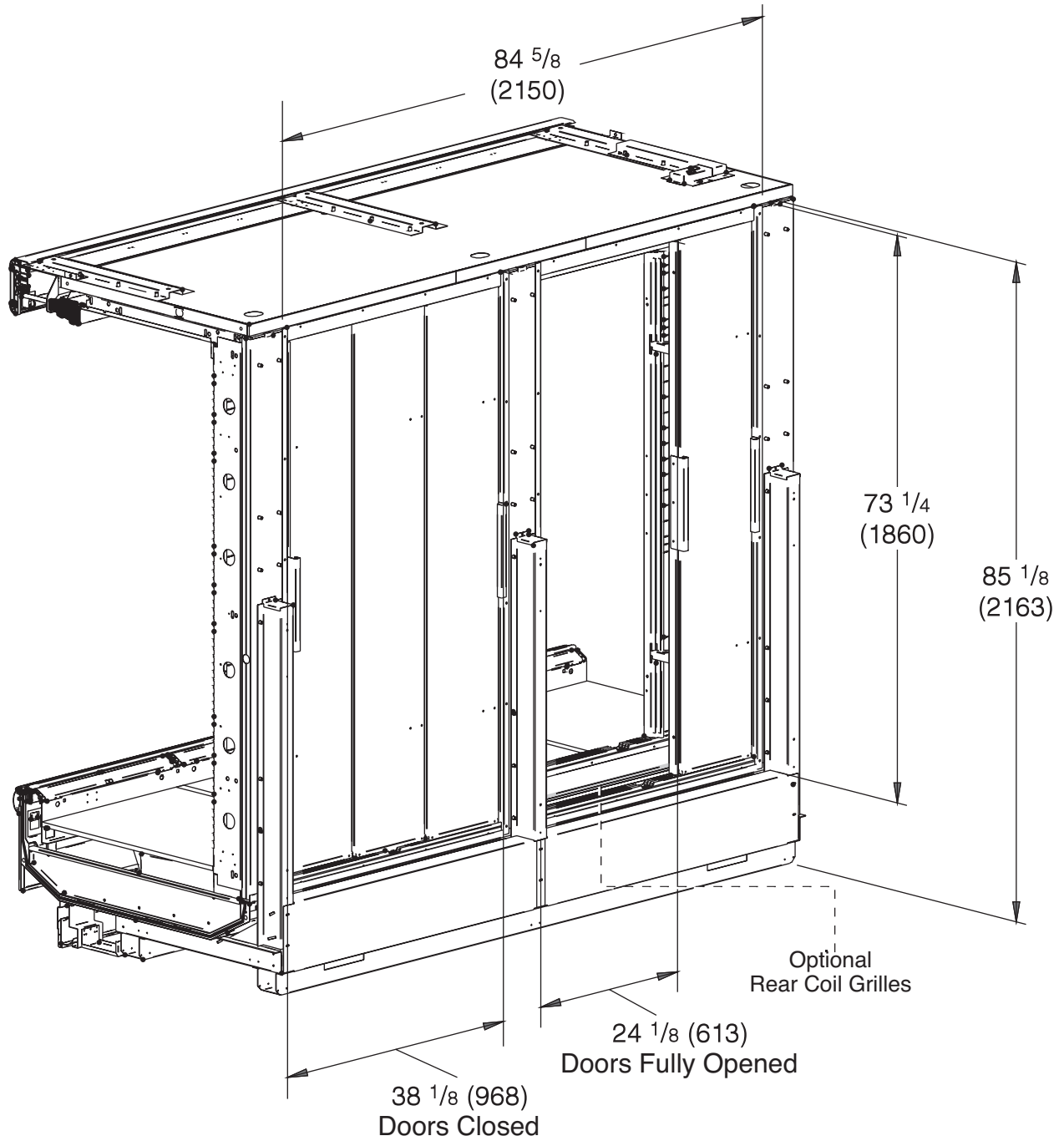

Rear View of 8 Foot Merchandiser

Double-walled telescoping doors slide both left and right

Note: Consult the Cooler Close-off kit for instructions on connecting the merchandiser to the cooler.

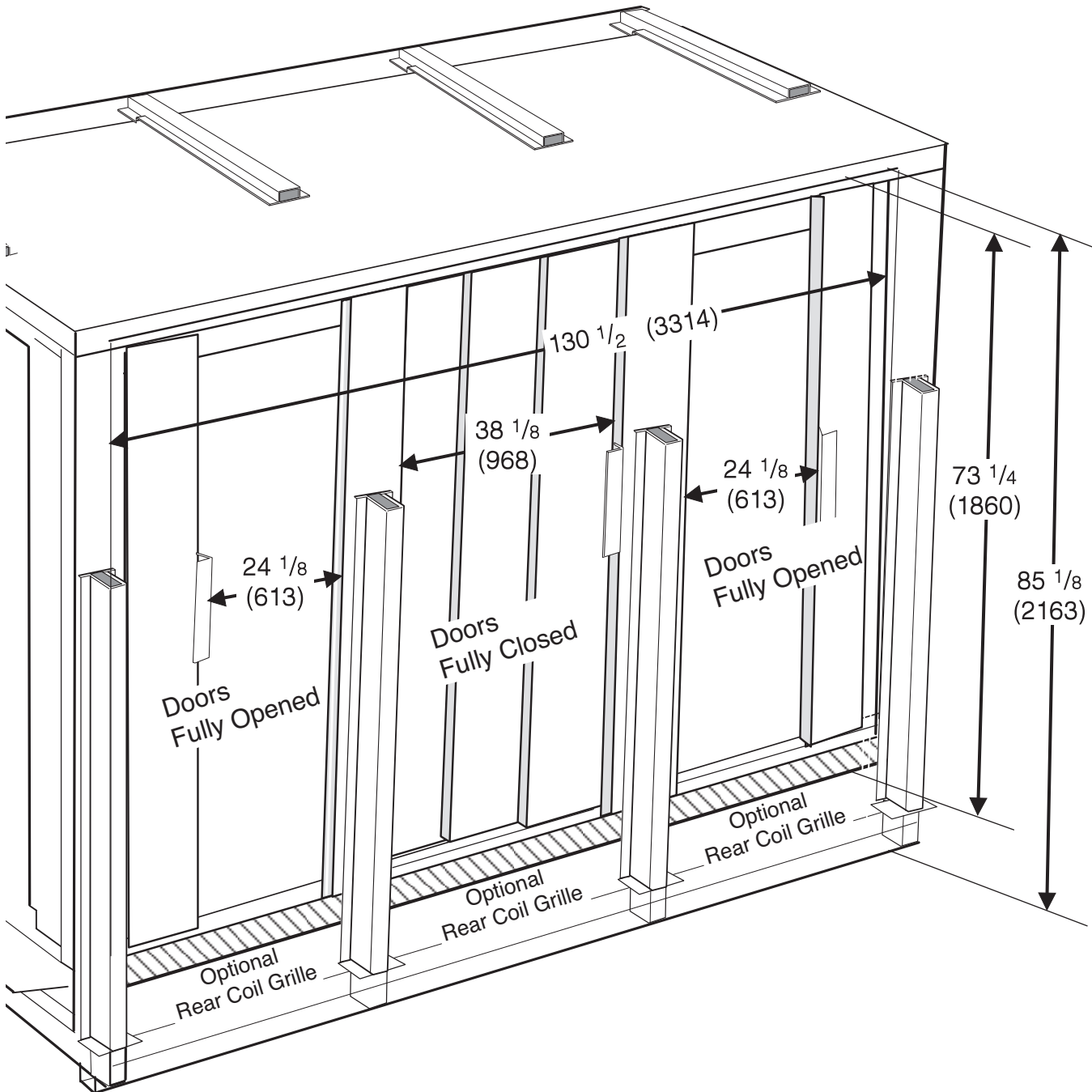

Rear View of 8 Foot Merchandiser
Double-walled telescoping doors slide both left and right

Note: Consult the Cooler Close-off kit for instructions on connecting the merchandiser to the cooler.