

We reserve the right to change or revise specifications and product design in connection with any feature of our products. Such changes do not entitle the buyer to corresponding changes, improvements, additions or replacements for equipment previously sold or shipped.

Item Part #	Description	Wiring Item #	Item Part #	Description	Wiring Item #
FAN ASSEMBLIES			HEATERS		
8 Ft & 12 Ft			D.	Canopy Anti-Sweat Heater	(4)
A.	7W Standard Fan Assembly	(1)	<u>0512501</u>	8 ft (HE.4851176)	
0058698	Fan Motor, Evaporator (MO.4410102)		<u>0512503</u>	12 ft (HE.4851178)	
0142780	Fan Blade (FB.0142780)		LAMPS & BALLASTS		
	7W Energy Efficient Fan Assembly	(1)	E.	Ballast, Electronic	(5)
0477654	Fan Motor, Evaporator (MO.4410545)		0480130	2 lamps (BA.4481676)	
0142780	Fan Blade (FB.0142780)		0480131	3 lamps (BA.4481654)	
			0480132	4 lamps (BA.4481677)	
THERMOSTATS			F.	Fluorescent Lamp	(6)
B.	0411744 Standard Non-adjustable Defrost Thermostat (CT.0411744)	(2)	<i>Replace with like fixtures</i>		
C.	Optional Adjustable Refrigeration Thermostat	(3)	LED FIXTURES AND POWER SUPPLY		
			G.	0501213 Power Supply (EP.4481861)	(7)
			H.	LED Canopy Fixture	(8)
			<i>Replace with like fixtures — See Page 5.</i>		
			I.	LED Shelf Fixture	(9)
			<i>Replace with like fixtures — See Page 5.</i>		

Note: Revision E adds Btu note (page 3), EcoShine LED (page 4) and parts (page 5), and revises canopy wiring diagram (page 6). Other changes marked by bar, underline or circle.



Engineering Plan Views

PHYSICAL DATA

Merchandiser Drip Pipe (in.)	1 1/4
Merchandiser Liquid Line (in.)	3/8
Merchandiser Suction Line (in.)	7/8



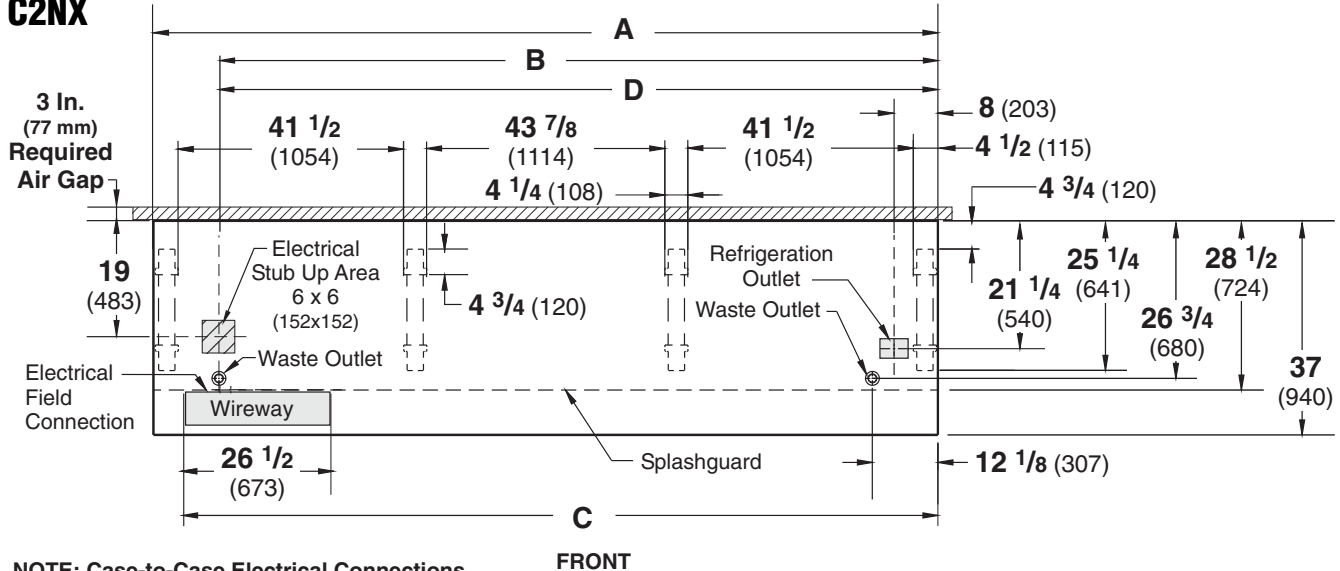

Dairy/Delicatessen Precut & Packaged Produce 01-2005

Dimensions shown as inches and (mm).

C2NX



NOTE: Case-to-Case Electrical Connections are made IN FRONT OF SPLASHGUARD.

	8 ft	12 ft
General		
(A) Case Length (without ends or partitions) (Each end and insulated partition adds 1 1/2 in. (38 mm) to case line up.) Maximum O/S dimension of case back to front (includes bumper)	96 3/8 (2448)	144 1/2 (3670)
Back of case to front of splashguard	37 (940)	37 (940)
Back of case to O/S edge of front leg	28 1/2 (724)	28 1/2 (724)
Distance between edges of external legs and center legs	25 1/4 (641)	25 1/4 (641)
Distance between edges of center legs	41 1/2 (1054)	41 1/2 (1054)
Distance between front legs and splashguard	NA	43 7/8 (1114)
	2 3/4 (70)	2 3/4 (70)
Electrical Service  (Electrical Field Wiring connection point)		
(B) RH End of case to center of stub up area	84 1/4 (2140)	132 3/8 (3363)
Back of case to center of stub up area	19 (483)	19 (483)
Length of electrical wireway 	26 1/2 (673)	26 1/2 (673)
(C) RH End of case to LH end of wireway	90 1/8 (2289)	138 1/4 (3511)
Waste Outlets (One each end) 		
(D) RH End of case to the center of LH waste outlet	84 1/4 (2140)	132 3/8 (3363)
RH End of case to the center of RH waste outlet	12 1/8 (307)	12 1/8 (307)
Back O/S of case to center of waste outlets	26 3/4 (680)	26 3/4 (680)
Schedule 40 PVC drip pipe	1 1/4 (32)	1 1/4 (32)
Refrigeration Outlet 		
Back of case to center of refrigeration outlet	21 1/4 (540)	21 1/4 (540)
RH end of case to center of refrigeration outlet	8 (203)	8 (203)

Multi-deck, 3 Display Levels, 55 In. Back, Narrow Footprint

Dimensions shown as inches and (mm).

C2NX-XE

See Page 10 for shelf arrangement.

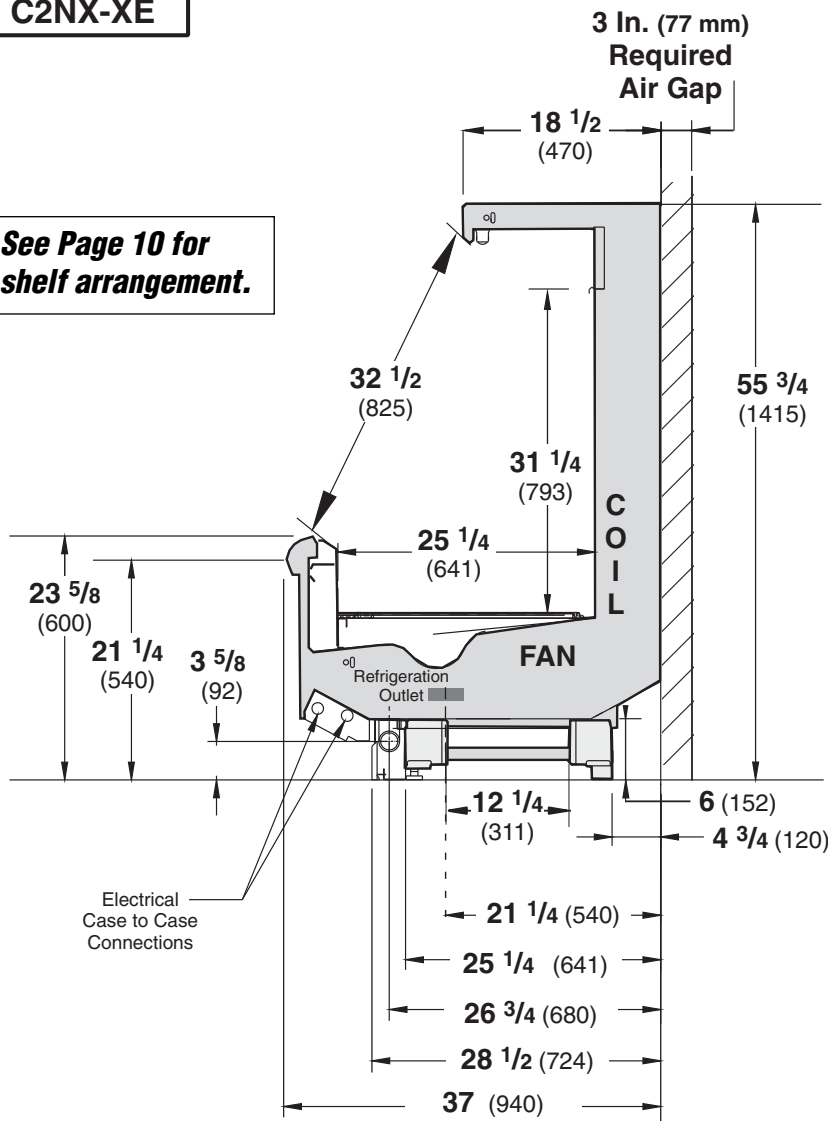

Impact Excel C2NX-XE
Dairy/Delicatessen
Precut & Packaged Produce

REFRIGERATION DATA

Note: This data is based on store temperature and humidity that does not exceed 75°F and 55% R.H.

	C2NX-XE
Discharge Air °F	29
Evaporator °F	21
Unit Sizing °F	19

Btu/hr/ft[‡] — Unlit Shelves^{‡‡}

C2NX-XE	Parallel	Conventional
UNLIT	1015	1080

[‡] Optional energy efficient motors reduce the refrigeration load by 21 Btu/hr/ft.
^{‡‡} Add 10 Btu/hr/ft per shelf row for LED fixtures.
 Add 20 Btu/hr/ft per shelf row for fluorescent lamps.

DEFROST DATA

	C2NX-XE
Frequency (hr)	6
Defrost Water (lb/ft/day)	7

(±15% based on case configuration and product loading.)

OFFTIME	C2NX-XE
Temp Term °F	48°F
Failsafe Minutes	30

ELECTRIC OR GAS Not Recommended

Standard Defrost Thermostat

Close on rise: close 48°F – open 33°F

CONVENTIONAL CONTROLS

Low Pressure Backup Control

	C2NX-XE
CI/CO*	14°F / 4°F

Indoor Unit Only, Pressure Defrost

Termination* 48°F

*Use a Temperature Pressure Chart to determine PSIG conversions.

Estimated Charge ** C2NX-XE

8 ft	2.3 lb	37 oz	1.0 kg
12 ft	3.3 lb	53 oz	1.5 kg

**This is an average for all refrigerant types. Actual refrigerant charge may vary by approximately half a pound.

NSF Certification

This merchandiser model is manufactured to meet ANSI/NSF (National Sanitation Foundation) Standard #7 requirements for construction, materials & cleanability.

Impact Excel C2NX-XE
Dairy/Delicatessen
Precut & Packaged Produce

Electrical Data

			8 ft	12 ft		
Number of Fans—7W			2	3		
			Amperes		Watts	
			8 ft	12 ft	8 ft	12 ft
Evaporator Fan						
120V	60Hz	Standard	1.00	1.50	78	117
120V	50Hz	Standard	1.10	1.65	84	126
230V	60Hz	Export	0.50	0.75	78	117
230V	50Hz	Export	0.56	0.84	84	126
120V	60Hz	Energy Efficient	0.38	0.57	28	42
230V	60Hz	Energy Efficient	0.20	0.30	28	42
Minimum Circuit Ampacity †						
120V	60Hz	Standard	1.20	1.70		
120V	50Hz	Standard	1.30	1.85		
230V	60Hz	Export	0.70	0.95		
230V	50Hz	Export	0.76	1.04		
120V	60Hz	Energy Efficient	0.58	0.77		
230V	60Hz	Energy Efficient	0.40	0.50		
Maximum Over Current Protection 120V			20	20		
Maximum Over Current Protection 230V			15	15		
Anti-sweat Heaters						
120V	50/60Hz	Standard	0.20	0.30	24	36
Standard Lighting (T-8 Fluorescent)						
1 Row Canopy			0.51	0.77	59	85
Optional Lighting (T-8 Fluorescent)						
Additional 1 Row Canopy			0.51	0.77	59	85
1 Row Rail Light			0.51	0.77	59	85
2 Rows of Shelves			1.02	1.54	118	170
Optional EcoShine CRI (120VAC, 50/60Hz)						
2 Row Canopy			0.55	0.82	66	98
2 Rows of shelves			0.39	0.58	47	70
Optional EcoShine High CRI (120VAC, 50/60Hz)						
2 Row Canopy			0.63	0.93	75	112
2 Rows of shelves			0.47	0.70	56	84
Optional Always*Bright LED Lighting						
2 Row Canopy			0.71	1.08	85	130
2 Rows of Shelves			0.47	0.67	56	80

120V Lighting Circuit Total = Standard Lighting + Total Optional Lighting + Optional Shelf Lighting

230V Lighting Circuit Total = Multiply 120V Lighting Circuit Total by 0.52

† MCA does not include Canopy A/S Heaters because heaters are wired separately from fans

Product Data

<i>Recommended Usable Cube</i> ¹ (Cu Ft/Ft)	3.39 ft ³ /ft (0.32 m ³ /m)
<i>AHRI Total Display Area</i> ² (Sq Ft/Ft)	2.98 ft ² /ft (0.91 m ² /m)
<i>Shelf Area</i> ³ (Sq Ft/Ft)	4.29 ft ² /ft (1.31 m ² /m)

¹ AHRI Refrigerated Volume less shelving and other unusable space: Refrigerated Volume/Unit of Length, ft³/ft [m³/m]

² Computed using AHRI 1200 standard methodology: Total Display Area, ft² [m²]/Unit of Length, ft [m]

³ Shelf surface area is composed of bottom deck plus standard shelf complement, as shown in the Hussmann

Product Reference Guide. The standard shelf complement for this model is (1) row of 12-inch shelf and (1) row of 14-inch shelf.

ESTIMATED SHIPPING WEIGHT ⁴			
Case	8 ft		Solid End
	<i>12 ft</i>		<i>(each)</i>
lb (kg)	1000 (454)	1200 (544)	75 (34)

⁴ Actual weights will vary according to optional kits included.

PARTS LIST (Continued from Page 1)						
Item	Part #	Description		Item	Part #	Description
LED FIXTURES AND POWER SUPPLY						
G.	0501213	Power Supply (EP.4481861) (7)		I.	EcoShine LED Shelf Fixture (9)	
H.	EcoShine LED Canopy Fixture (8)		4441590	48-inch	2900K	HCRI
	4441720	Front	48-inch	4441591	48-inch	3500K HCRI
	4441722	Front	48-inch	4441592	48-inch	3500K
	4441724	Front	48-inch	4441593	48-inch	4100K
	4441726	Front	48-inch			
	4441721	Rear	48-inch			
	4441723	Rear	48-inch			
	4441725	Rear	48-inch			
	4441727	Rear	48-inch			

Note: Always*Bright lamps will be replaced with the latest generation of EcoShine lamps.

Fan Wiring Offtime Defrost

2 & 3 Fans

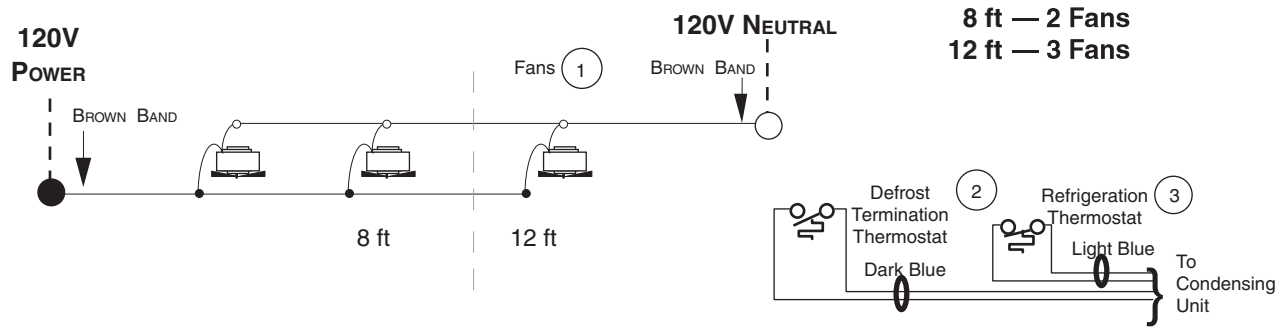

Canopy Light Circuits — Fluorescent Fixtures

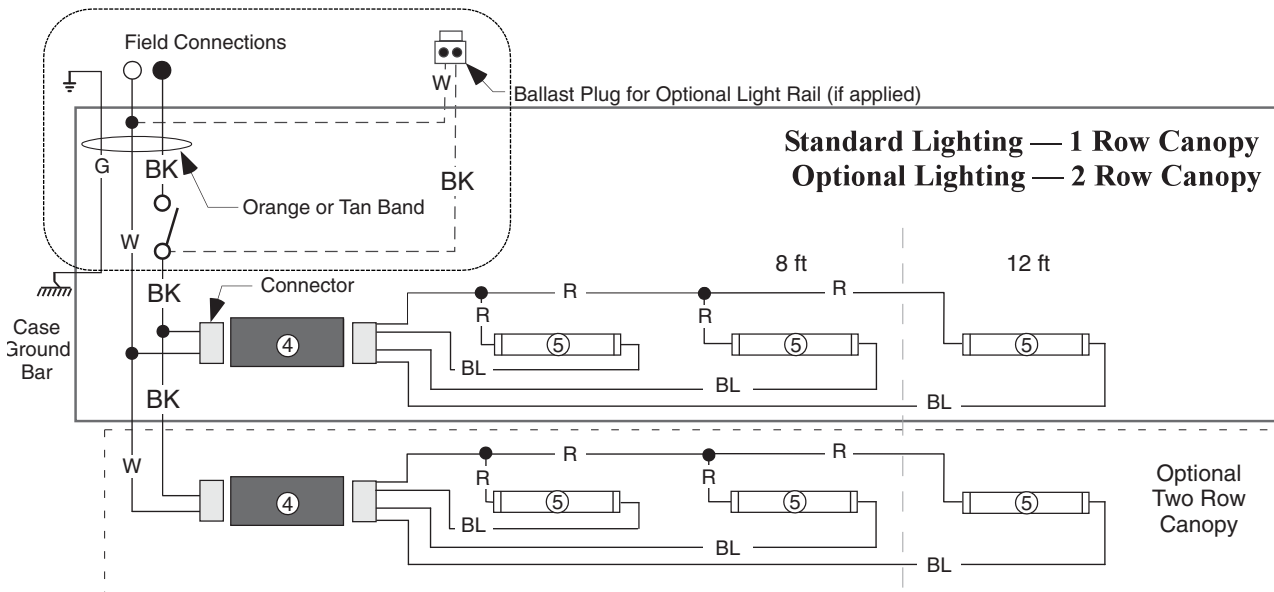

Optional Lighting — 1 Row Rail

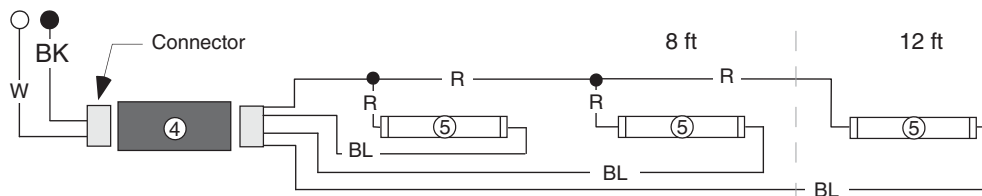

WARNING

All components must have mechanical ground, and the merchandiser must be grounded.

CIRCLED NUMBERS = PARTS LIST ITEM NUMBERS

R = Red Y = Yellow G = Green BL = Blue BK = Black W = White

● = 120V POWER ○ = 120V NEUTRAL ⊥ = FIELD GROUND ⏏ = CASE GROUND

Canopy Anti-Sweat Heater

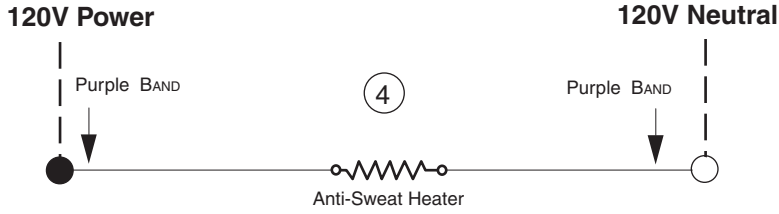

Optional Shelf Lighting Fluorescent Fixtures

Optional Shelf Harness and Light Circuits for Three Rows of Shelves

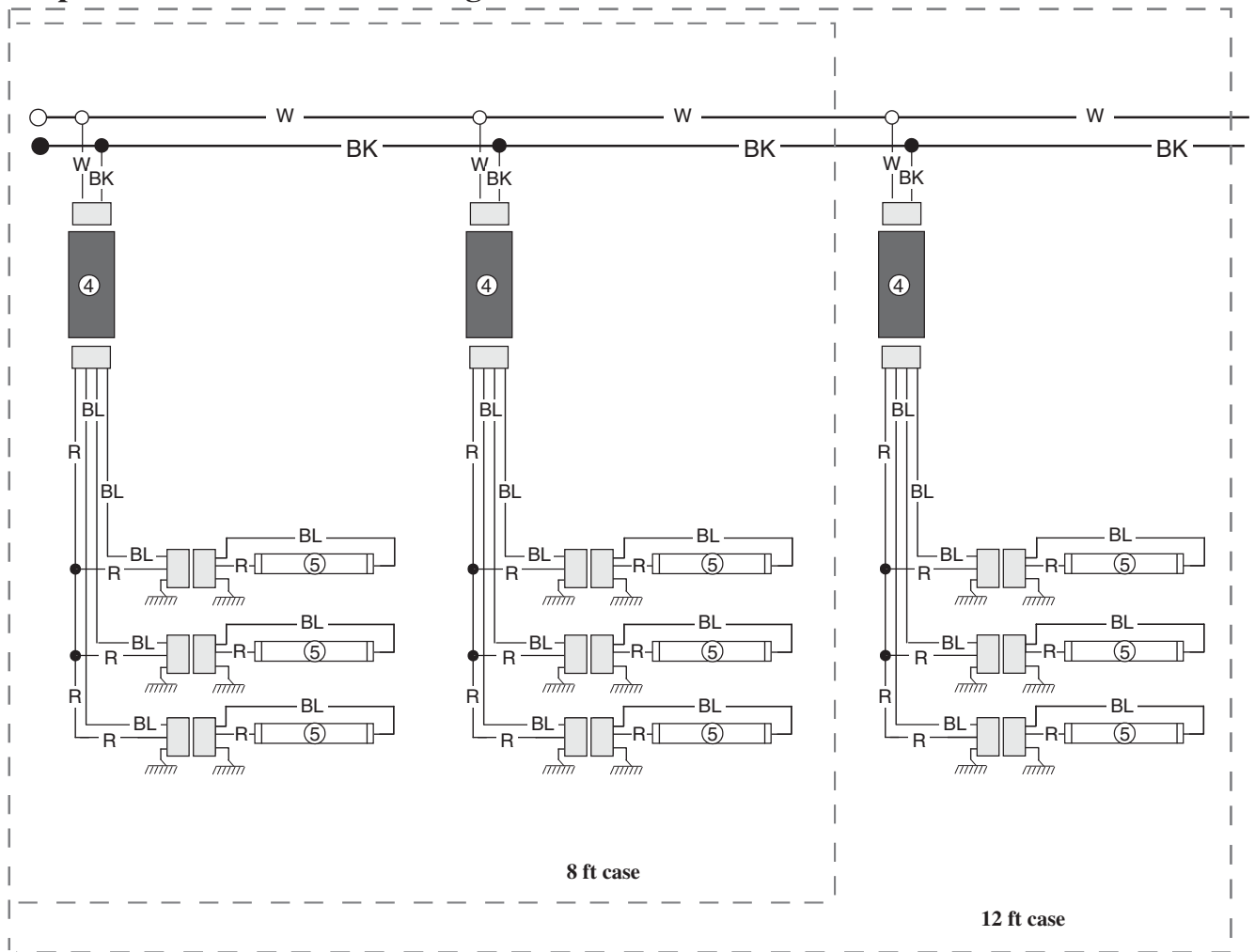

WARNING

All components must have mechanical ground, and the merchandiser must be grounded.

CIRCLED NUMBERS = PARTS LIST ITEM NUMBERS

R = Red Y = Yellow G = Green BL = Blue Bk = Black W = White

● = 120V POWER ○ = 120V NEUTRAL ⚡ = FIELD GROUND m = CASE GROUND

Optional Canopy Lighting LED Fixtures

LED Canopy Lighting — 2 Row Canopy

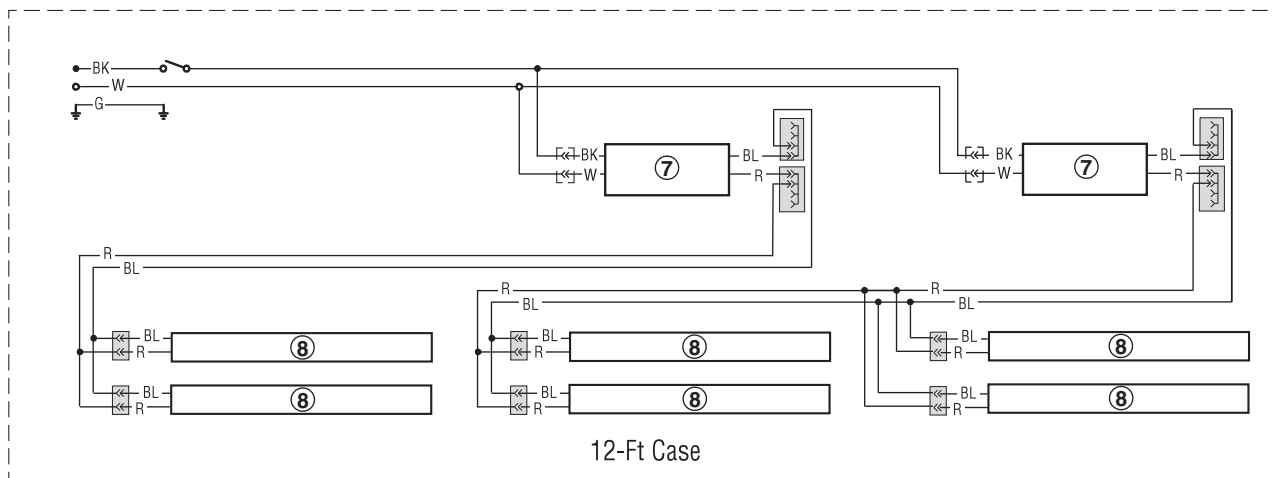
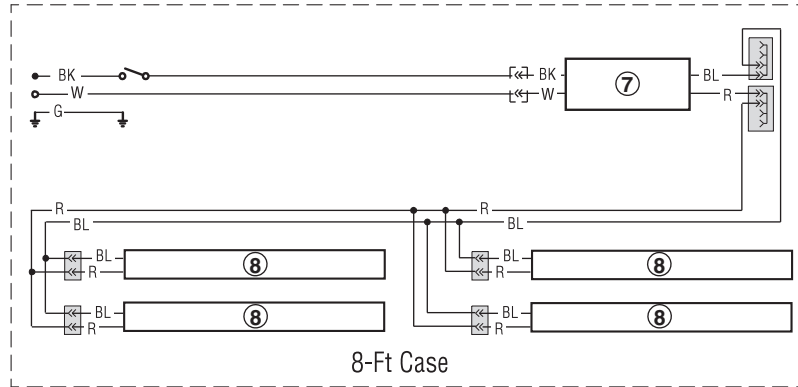

WARNING

All components must have mechanical ground, and the merchandiser must be grounded.

CIRCLED NUMBERS = PARTS LIST ITEM NUMBERS

R = Red Y = Yellow G = Green BL = Blue BK = Black W = White

● = 120V POWER ○ = 120V NEUTRAL ⊥ = FIELD GROUND ≡ = CASE GROUND

Optional Shelf Lighting LED Fixtures

Optional Shelf Harness and LED Light Circuits for 3, 9, 5, 7 & 7 Rows of Shelves

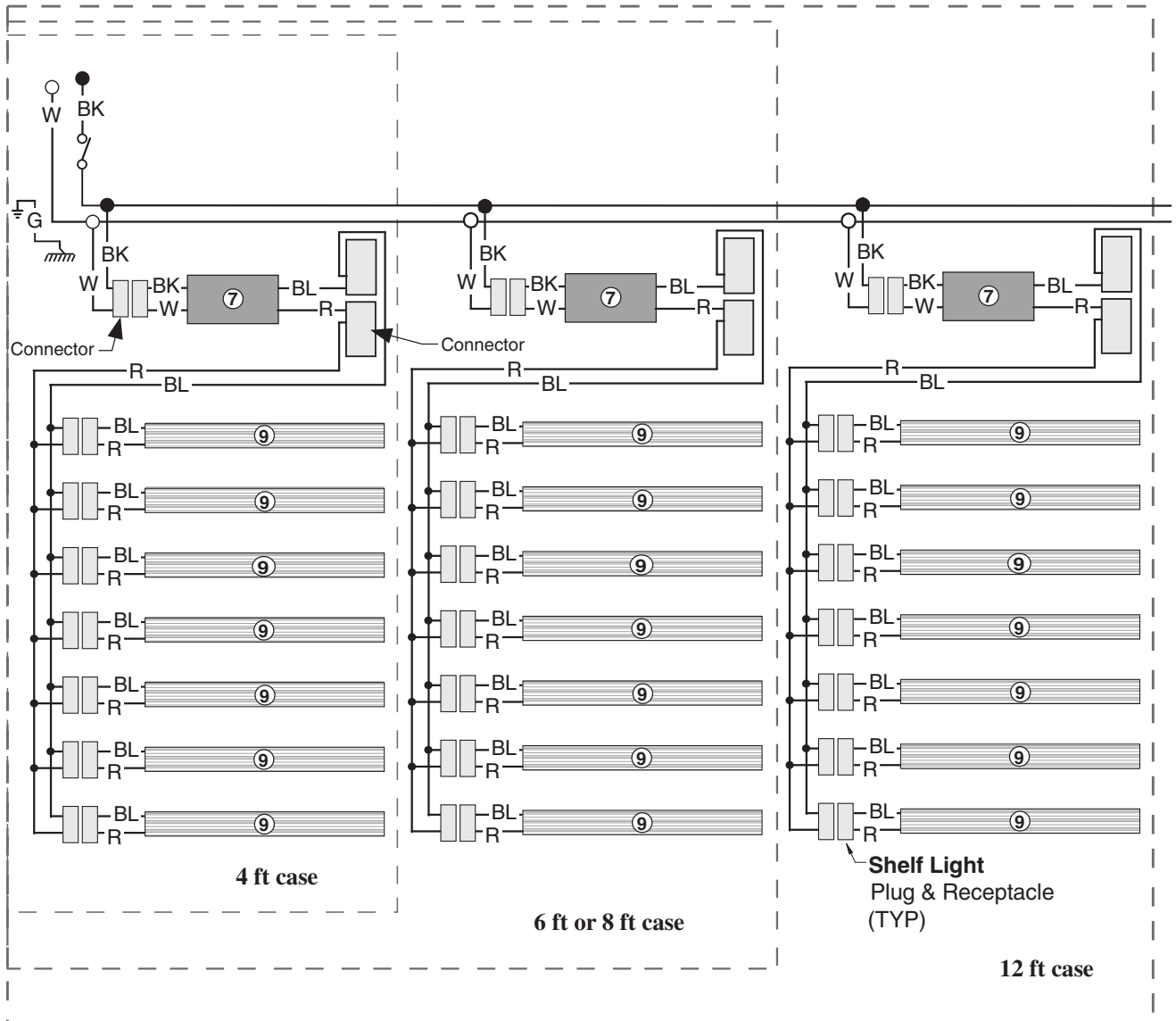

WARNING

All components must have mechanical ground, and the merchandiser must be grounded.

CIRCLED NUMBERS = PARTS LIST ITEM NUMBERS

R = Red G = Green BL = Blue BK = Black W = White

● = 120V POWER ○ = 120V NEUTRAL ⊥ = FIELD GROUND $\overline{\overline{\overline{m}}}$ = CASE GROUND

Impact Excel C2NX-XE
Dairy/Delicatessen
Precut & Packaged Produce

SHELF CONFIGURATION

This merchandiser is designed for two or three shelves.

The depth of the shelf used in the top eight (8) shelf hole locations is critical to case performance.

If a shelf is placed in one of the top eight (8) locations it must comply with the angle/depth requirements listed below.

Shelf Angle	Maximum Shelf Depth
0°	12 in.
15°	14 in. or less
30°	18 in. or less
45°	18 in. or less

NOTE: Shelves placed in the lower positions may be up to 18 in. deep when positioned at a 0° angle.

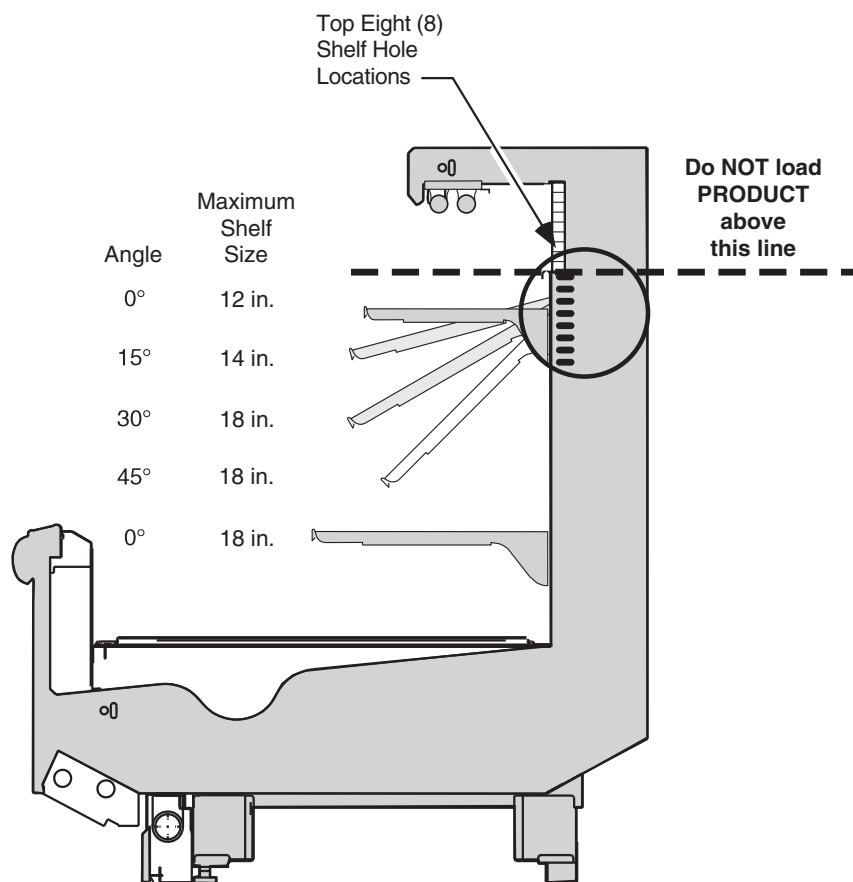

Impact Excel C2NX-XE
Dairy/Delicatessen
Precut & Packaged Produce

The ballast for the canopy and shelf lamps is located behind the canopy on the left-hand end (when facing case) of the merchandiser.

To access the ballast:

1. Remove screws at bottom edge of canopy and rear of light channel.
2. Lower light channel which will pivot on hinge.
3. Service or replace ballasts as required.
4. Reassemble items as they were originally installed.

NOTE: Rail lamp ballast is located in the electrical raceway.

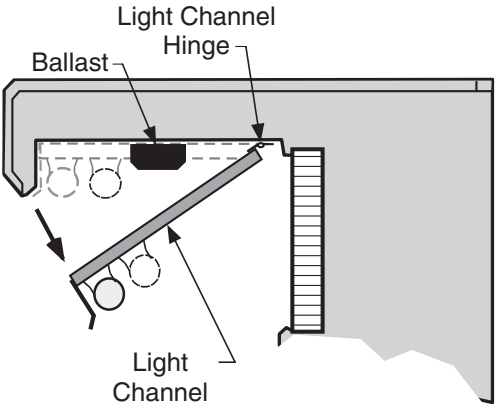
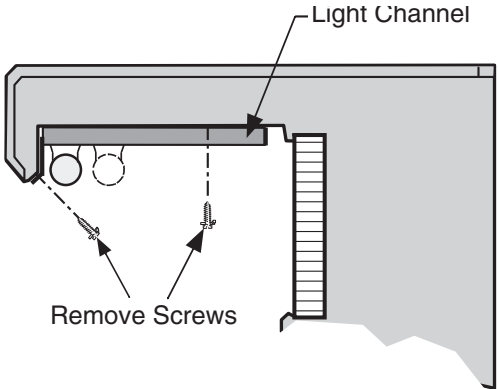

CANOPY ANTI-SWEAT HEATER

The canopy anti-sweat heater location is shown below. Connections are in the electrical wireway.

