

DOE 2017
Energy Efficiency
Compliant

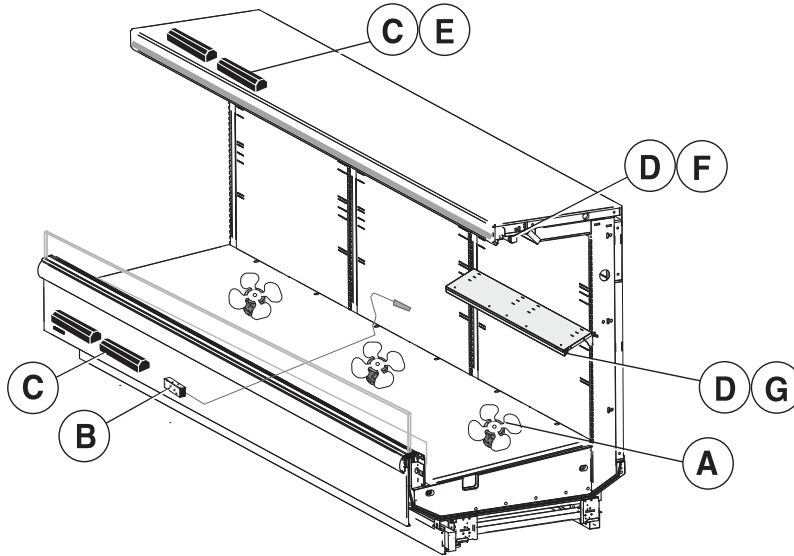

Scan QR code to
access product
information on your
mobile device.

We reserve the right to change or revise specifications and product design in connection with any feature of our products. Such changes do not entitle the buyer to corresponding changes, improvements, additions or replacements for equipment previously sold or shipped.

Item	Part #	Description	Wiring Item #	Item	Part #	Description	Wiring Item #
FAN ASSEMBLIES				LED FIXTURES AND POWER SUPPLY			
	4 Ft, 8 Ft & 12 Ft			E.	0501213	Power Supply	(5)
A.	12W Energy Efficient Fan Assembly		(1)	F.		LED Canopy Fixture	(6)
	0477655	Fan Motor, Evaporator				<i>Replace with like fixtures</i>	
	0461805	Fan Blade		G.		LED Shelf Fixture	(7)
						<i>Replace with like fixtures</i>	
THERMOSTATS							
B.	Optional Adjustable Refrigeration Thermostat(2)						
LAMPS AND BALLASTS							
C.	Ballast, Electronic		(3)				
	0480130	2 lamps					
	0480131	3 lamps					
	0480132	4 lamps					
D.	Fluorescent Lamp		(4)				
		<i>Replace with like fixtures</i>					

Data sheet-Excel-B3XC-LGEP

Note: Revision K: April 2017. Updated LED energy values. Other changes marked with a bar, circle or underline.

Engineering Plan Views

PHYSICAL DATA	
Merchandiser Drip Pipe (in.)	1 1/4
Merchandiser Liquid Line (in.)	3/8
Merchandiser Suction Line (in.)	7/8

Bulk Convertible
05-2006

Dimensions shown as inches and (mm).

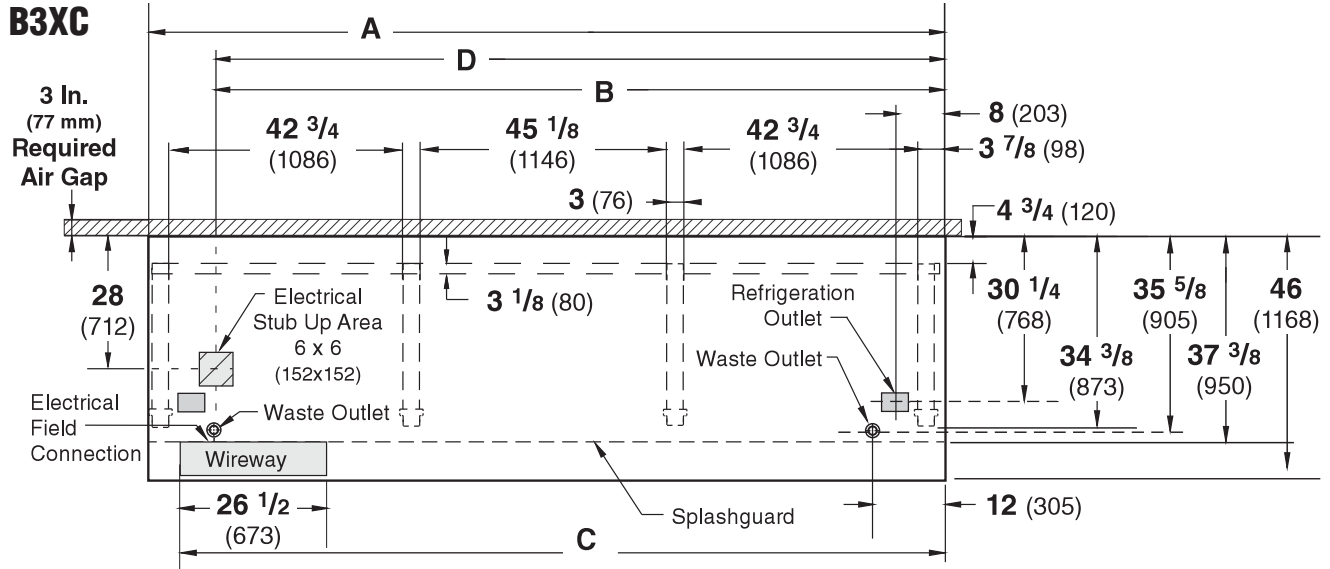

NOTE: Case-to-Case Electrical Connections are made IN FRONT OF SPLASHGUARD.

FRONT

	4 ft	8 ft	12 ft
General			
(A) Case Length (<i>without ends or partitions</i>) (Each end and insulated partition adds 1 1/2 in. (38 mm) to case line up.) Maximum O/S dimension of case back to front (includes bumper)	48 1/4 (1226)	96 3/8 (2448)	144 1/2 (3670)
Back of case to front of splashguard	46 (1168)	46 (1168)	46 (1168)
Back of case to O/S edge of front leg	37 3/8 (950)	37 3/8 (950)	37 3/8 (950)
Distance between edges of external legs and center legs	34 3/8 (873)	34 3/8 (873)	34 3/8 (873)
Distance between edges of center legs	NA	42 3/4 (1086)	42 3/4 (1086)
Distance between front legs and splashguard	NA	NA	45 1/8 (1146)
	2 5/8 (66)	2 5/8 (66)	2 5/8 (66)
Electrical Service <input checked="" type="checkbox"/> (<i>Electrical Field Wiring connection point</i>)			
(B) RH End of case to center of stub up area	40 1/2 (1029)	84 1/4 (2140)	132 3/8 (3363)
Back of case to center of stub up area	28 (712)	28 (712)	28 (712)
Length of electrical wireway <input type="checkbox"/> Wireway	26 1/2 (673)	26 1/2 (673)	26 1/2 (673)
(C) RH End of case to LH end of wireway	40 3/4 (1035)	90 1/8 (2289)	138 1/4 (3511)
Waste Outlets (<i>One each end</i>) <input checked="" type="checkbox"/>			
(D) RH End of case to the center of LH waste outlet	36 1/2 (927)	84 3/8 (2140)	132 1/2 (3366)
RH End of case to the center of RH waste outlet	12 (305)	12 (305)	12 (305)
Back O/S of case to center of waste outlets	35 5/8 (905)	35 5/8 (905)	35 5/8 (905)
Schedule 40 PVC drip pipe	1 1/4 (32)	1 1/4 (32)	1 1/4 (32)
Refrigeration Outlet <input type="checkbox"/>			
Back of case to center of refrigeration outlet	30 1/4 (768)	30 1/4 (768)	30 1/4 (768)
RH end of case to center of refrigeration outlet	8 (203)	8 (203)	8 (203)

Multi-deck, Wide Footprint, Extended Canopy Low Front with Glass, 3 Display Levels



Husmann refrigerated merchandisers configured for sale for use in the United States meet or surpass the requirements of the DOE 2017 energy efficiency standards.

Dimensions shown as inches and (mm).

B3XC-LGEP

See Page 11 for shelf arrangement.

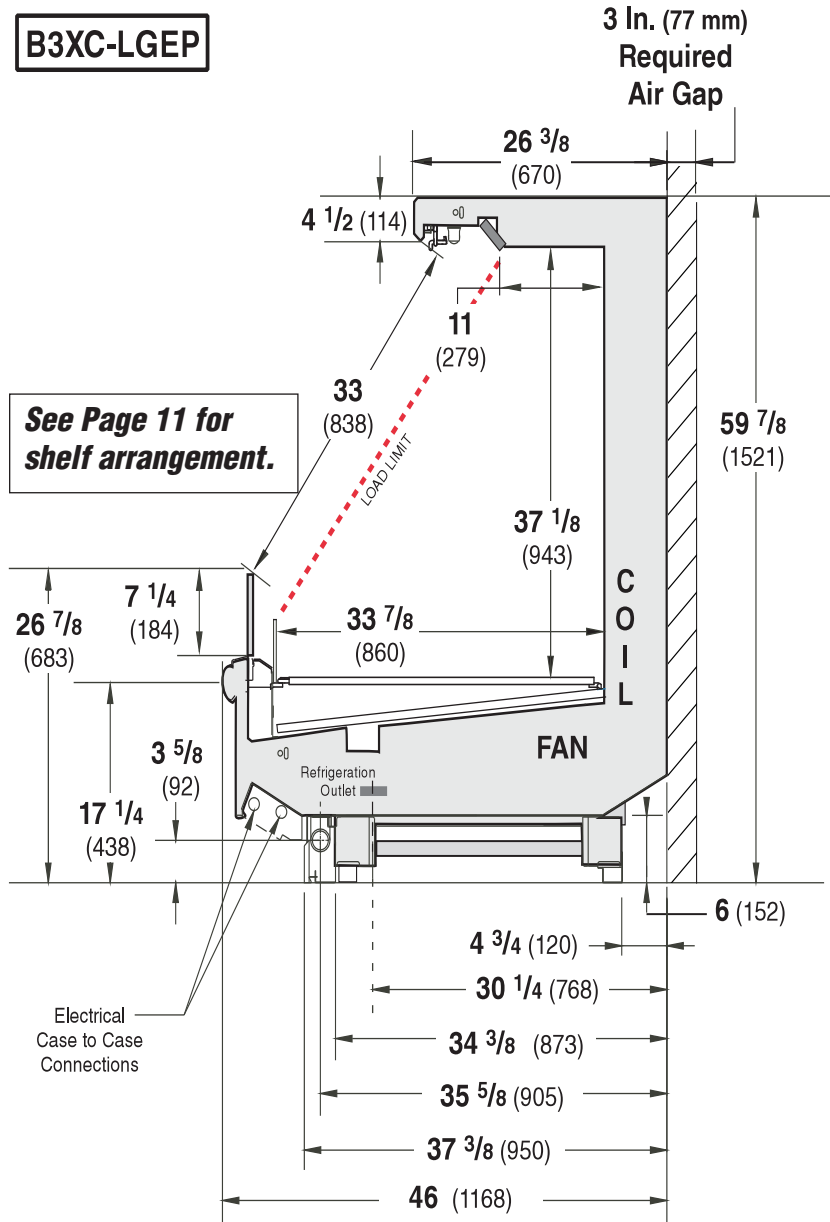

Excel B3XC-LGEP Bulk Convertible

REFRIGERATION DATA

Note: This data is based on store temperature and humidity that does not exceed 75°F and 55% R.H.

B3XC-LGEP	DAIRY/DELI/PRODUCE†§	
	UNLIT	LIT
Discharge Air °F	33	32
Evaporator °F	28	26
Unit Sizing °F	26	24

† For red meat application, lower evaporator temperature and unit sizing 3°F increase Btu 5%.

§ Average evaporator temperature shown. Use dew point for high glide refrigerants for unit sizing. Care should be taken to use the dew point in PT tables for measuring and adjusting superheat. Adjust evaporator pressure as needed to maintain discharge air temperature shown.

Btu/hr/ft — Unlit Shelves†

B3XC-LGEP	DAIRY/DELI/PRODUCE	
	Parallel	Conventional
UNLIT	1003	1073

† Add 10 Btu/hr/ft per shelf row for LED fixtures. Add 20 Btu/hr/ft per shelf row for fluorescent lamps.

DEFROST DATA

	B3XC-LGEP
Frequency (hr)	8
Defrost Water (lb/ft/day)	7

(±15% based on case configuration and product loading.)

OFFTIME	B3XC-LGEP
Time (minutes)	30

ELECTRIC OR GAS Not Recommended

CONVENTIONAL CONTROLS

Low Pressure Backup Control

CI/CO*

B3XC-LGEP	DAIRY/DELI/PRODUCE‡
Temp (°F)	19°F / 9°F

Indoor Unit Only, Pressure Defrost

Termination* 48°F

* Use a Temperature Pressure Chart to determine PSIG conversions.

‡ For red meat application, reduce low pressure backup control by 3°F.

NSF Certification

This merchandiser model is manufactured to meet ANSI/NSF (National Sanitation Foundation) Standard #7 requirements for construction, materials & cleanability.

Estimated Charge **	B3XC-LGEP	
4 ft	1.6 lb	26 oz 0.7 kg
8 ft	3.2 lb	51 oz 1.5 kg
12 ft	4.5 lb	72 oz 2.0 kg

**This is an average for all refrigerant types. Actual refrigerant charge may vary by approximately half a pound.

Excel B3XC-LGEP Bulk Convertible

Electrical Data

	4 ft	8 ft	12 ft			
Number of Fans—12W	1	2	3			
	Amperes			Watts		
	4 ft	8 ft	12 ft	4 ft	8 ft	12 ft
Evaporator Fan						
120V 60Hz Standard Energy Efficient	0.30	0.60	0.90	18	36	54
230V 60Hz Standard Energy Efficient	0.15	0.30	0.45	18	36	54
230V 60Hz Export	0.33	0.66	0.99	50	100	150
230V 50Hz Export	0.38	0.76	1.14	57	114	171
Minimum Circuit Ampacity						
120V 60Hz Standard Energy Efficient	0.50	0.80	1.10			
230V 60Hz Standard Energy Efficient	0.35	0.50	0.65			
230V 60Hz Export	0.53	0.86	1.19			
230V 50Hz Export	0.58	0.96	1.34			
Maximum Over Current Protection 120V	20	20	20			
Maximum Over Current Protection 230V	15	15	15			
Standard Lighting (T-8 fluorescent)						
1 Row Canopy	0.26	0.51	0.77	30	59	85

ONLY LIGHTING CONFIGURATIONS THAT ARE COMPLIANT WITH THE U.S. DEPT. OF ENERGY (DOE) 2017 REGULATION ARE AVAILABLE FOR SALE FOR USE IN THE U.S.A.

Optional Lighting (T-8 fluorescent)

1 Row Rail Light	NA — Glass front does not accept rail light					
1 Row of Shelves	0.26	0.51	0.77	30	59	85
2 Rows of Shelves	0.51	1.02	1.54	59	118	170
3 Rows of Shelves	0.77	1.53	2.31	89	177	255

EcoShine II Canopy

EcoShine II	0.16	0.32	0.48	19.3	38.6	58.0
EcoShine II HO	0.22	0.44	0.66	26.5	53.0	79.4

EcoShine II Shelves

1 Row of Shelves	0.08	0.16	0.25	9.9	19.8	29.7
2 Rows of Shelves	0.16	0.33	0.49	19.8	39.5	59.3
3 Rows of Shelves	0.25	0.49	0.74	29.7	59.3	89.0

120V Lighting Circuit Total = Standard Lighting + Total Optional Lighting + Optional Shelf Lighting

120V LED Lighting Circuit Total = Canopy Lighting + Shelf Lighting

230V Lighting Circuit Total = Multiply 120V Lighting Circuit Total by 0.52

Please note: some combinations of fluorescent lights on this case model may not be compliant with DOE 2017 and may not be available to order in the US and Canada. More lighting options are available with LED lights. The Hussmann Product Configurator will not allow lighting options that do not comply with the DOE 2017 standards.

Excel B3XC-LGEP Bulk Convertible

Product Data

<i>Recommended Usable Cube</i> ¹ (Cu Ft/Ft)	5.56 ft ³ /ft (0.52 m ³ /m)
<i>AHRI Total Display Area</i> ² (Sq Ft/Ft)	3.57 ft ² /ft (1.09 m ² /m)
<i>Shelf Area</i> ³ (Sq Ft/Ft)	5.70 ft ² /ft (1.74 m ² /m)

¹ AHRI Refrigerated Volume less shelving and other unusable space: Refrigerated Volume/Unit of Length, ft³/ft [m³/m]
² Computed using AHRI 1200 standard methodology: Total Display Area, ft² [m²]/Unit of Length, ft [m]
³ Shelf surface area is composed of bottom deck plus standard shelf complement, as shown in the Hussmann *Product Reference Guide*. The standard shelf complement for this model is (1) row of 16-inch shelf and (1) row of 18-inch shelf.

ESTIMATED SHIPPING WEIGHT ⁴				
Case	4 ft	8 ft	12 ft	Solid End
				(each)
lb (kg)	600 (272)	<u>1000 (454)</u>	1200 (544)	50 (23)

⁴ Actual weights will vary according to optional kits included.

Fan Wiring Offtime Defrost

1, 2 & 3 Fans

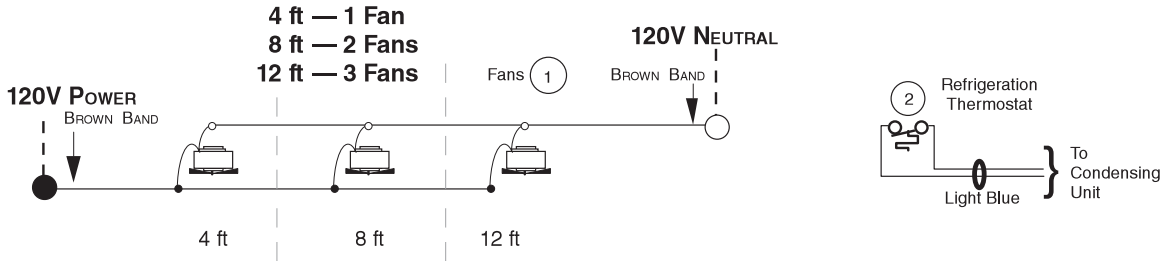

Light Circuits — Fluorescent Fixtures

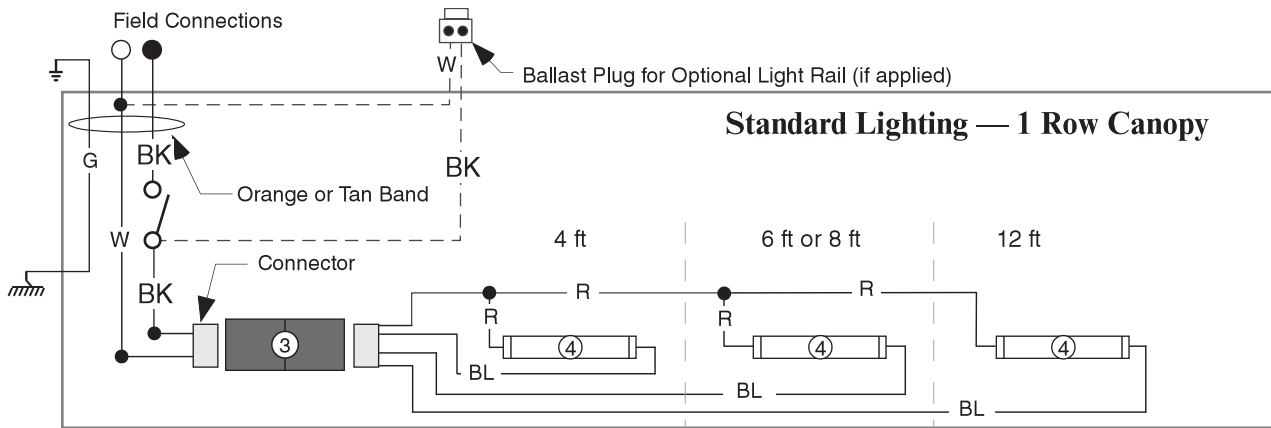

WARNING

All components must have mechanical ground, and the merchandiser must be grounded.

CIRCLED NUMBERS = PARTS LIST ITEM NUMBERS

R = Red Y = Yellow G = Green BL = Blue BK = Black W = White

● = 120V POWER ○ = 120V NEUTRAL ⚡ = FIELD GROUND ⏏ = CASE GROUND

Optional Shelf Lighting Fluorescent Fixtures

Optional Shelf Harness and Light Circuits for Three Rows of Shelves

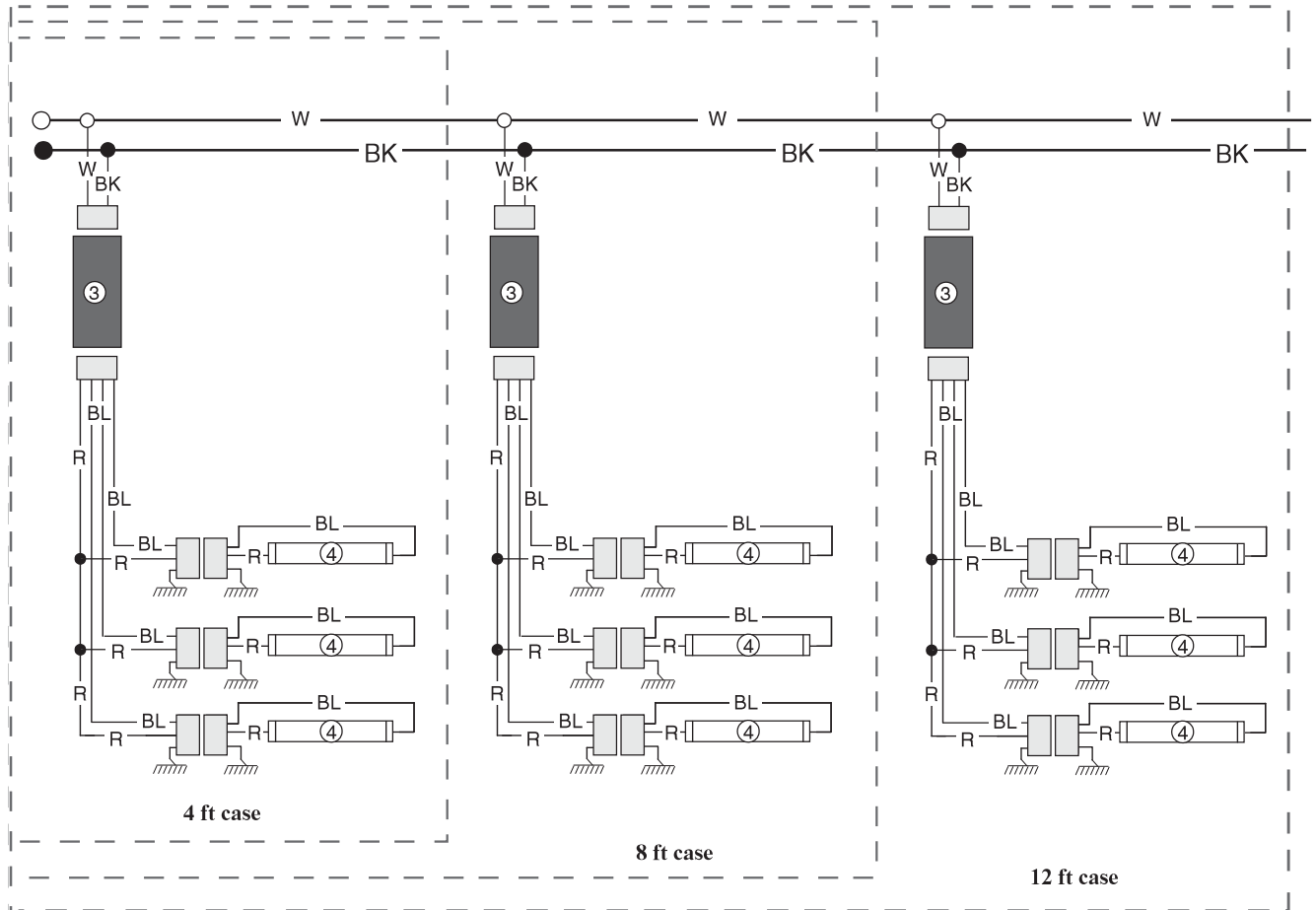

WARNING

All components must have mechanical ground, and the merchandiser must be grounded.

CIRCLED NUMBERS = PARTS LIST ITEM NUMBERS

R = Red Y = Yellow G = Green BL = Blue BK = Black W = White

● = 120V POWER ○ = 120V NEUTRAL ⚡ = FIELD GROUND ⚡ = CASE GROUND

Optional Shelf Lighting LED Fixtures

Optional Shelf Harness and LED Light Circuits for 2 or 3 Rows of Shelves

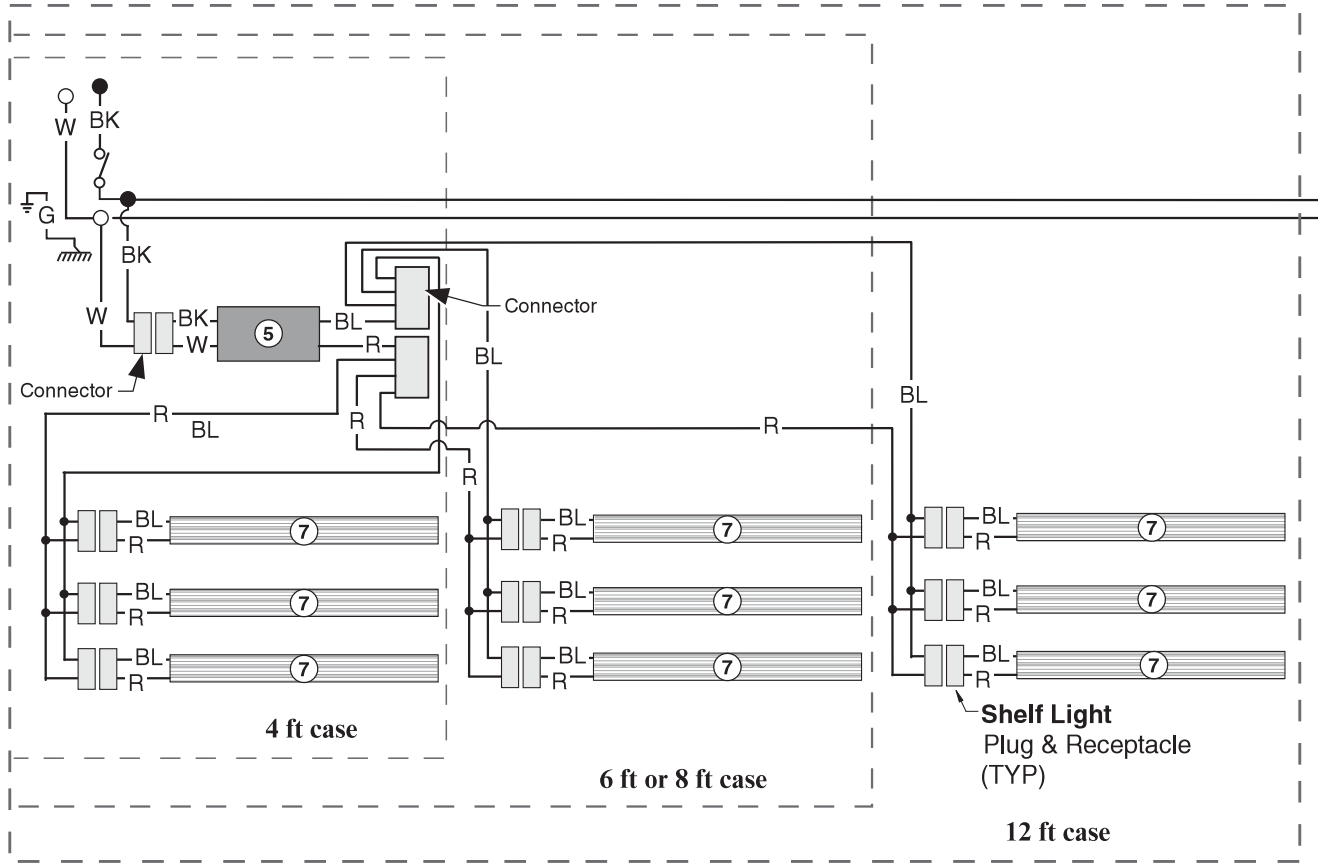

WARNING

All components must have mechanical ground, and the merchandiser must be grounded.

CIRCLED NUMBERS = PARTS LIST ITEM NUMBERS

R = Red G = Green BL = Blue BK = Black W = White
 ● = 120V POWER ○ = 120V NEUTRAL ⚡ = FIELD GROUND mm = CASE GROUND

Excel B3XC-LGEP

Bulk Convertible

SHELF CONFIGURATION

This case is designed for three (3) shelves.

The depth of each shelf is critical to case performance.

Top Shelf Depth

12 inches
or
14 inches

Second Shelf Depth

14 inches
or
16 inches

Third Shelf Depth

16 inches
or
18 inches
or
20 inches

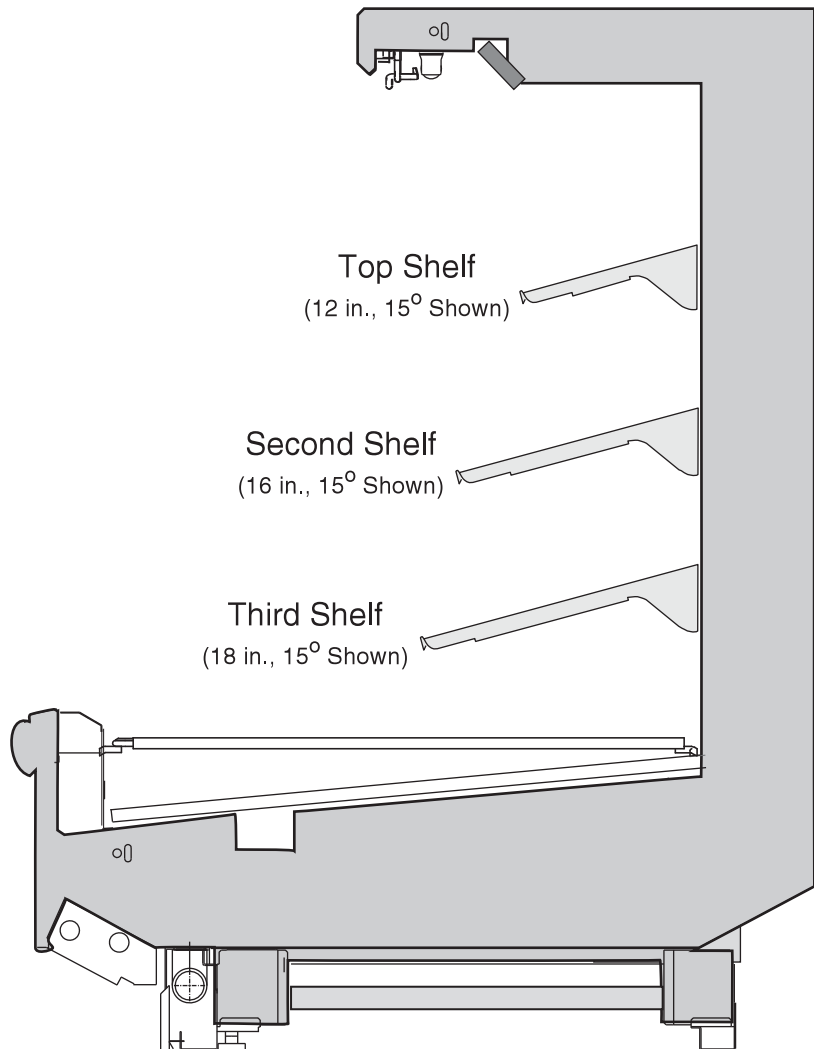

Excel B3XC-LGEP
Bulk Convertible

The ballast for the canopy and shelf lamps is located behind the canopy on the left-hand end (when facing case) of the merchandiser.

To access the ballast:

1. Remove screws at bottom edge of canopy and rear of light channel.
2. Lower light channel which will pivot on hinge.
3. Service or replace ballasts as required.
4. Reassemble items as they were originally installed.

NOTE: Rail lamp ballast is located in the electrical raceway.

