

We reserve the right to change or revise specifications and product design in connection with any feature of our products. Such changes do not entitle the buyer to corresponding changes, improvements, additions or replacements for equipment previously sold or shipped.

Item	Part #	Description	Wiring Item #	Item	Part #	Description	Wiring Item #
FAN ASSEMBLIES AND THERMOSTATS				HEATERS			
8 Ft, 10 Ft, 12 Ft, 14 Ft & 16 Ft				C. Anti-Sweat Heater (3)			
A.	12W Standard	Fan Assembly	(1)	0487118	8 ft & 10 ft (HE.4850668)		
	0047000	Fan Motor, Evaporator (MO.4410103)		0491966	12 ft (HE.4850834)		
	0142780	Fan Blade (FB.0142780) embossing toward motor		0487120	14 ft (HE.4850835)		
	12W Energy Efficient	Fan Assembly	(1)	0487121	16 ft (HE.4850836)		
	0477655	Fan Motor, Evaporator (MO.4410546)		LAMPS AND BALLASTS			
	0142780	Fan Blade (FB.0142780) embossing toward motor		D.	Ballast, Electronic		(4)
B.	Optional Adjustable Refrigeration Thermostat	(2)		0355398	3 Lamps (BA.4480118)		
	0448347	(CT.4481631)		0355716	2 Lamps (BA.0355716)		
				0447740	(BA.4481278)		
				E.	Fluorescent Lamp		(5)
					<i>Replace with like fixtures</i>		

Note: Revision E adds energy efficient fan Btu note on Page 3







Engineering Plan Views

PHYSICAL DATA

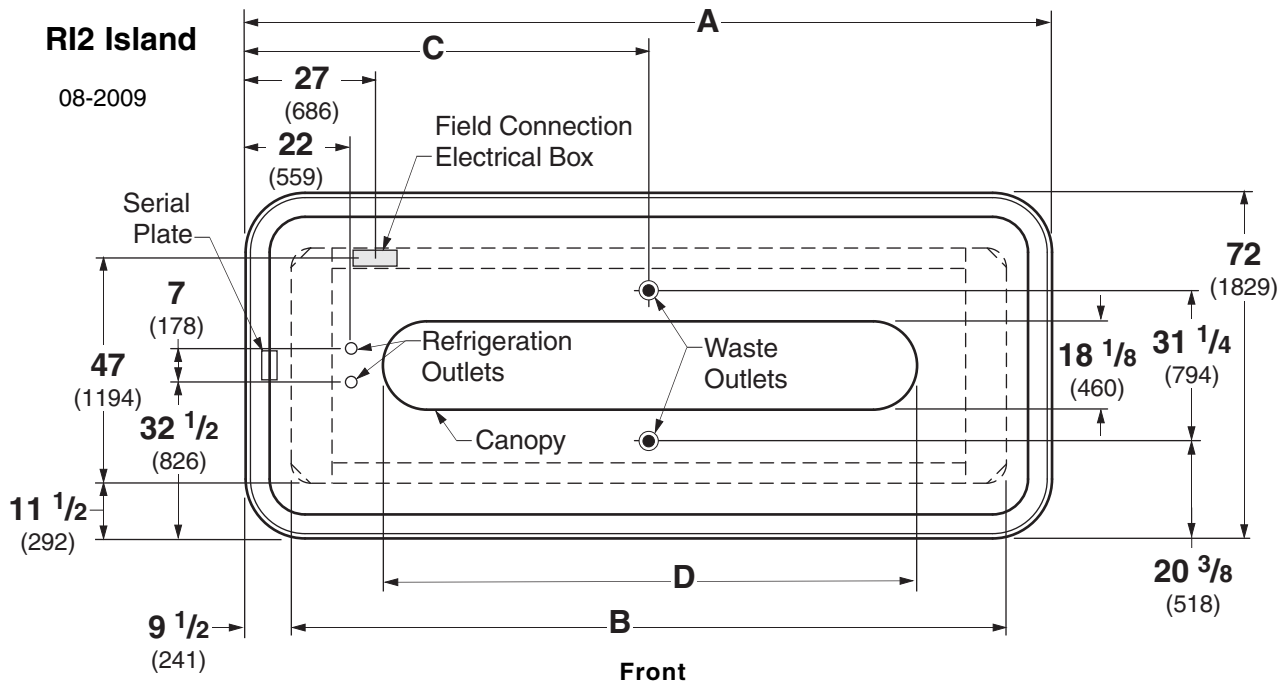
Merchandiser Drip Pipe (in.)	1 1/2
Merchandiser Liquid Line (in.)	3/8
Merchandiser Suction Line (in.)	5/8

Dimensions shown as inches and (mm).



	8 ft	10 ft	12 ft	14 ft	16 ft
General					
(A) Overall Case Length	96 (2438)	120 (3048)	144 (3658)	168 (4267)	192 (4876)
(B) Base Length	77 (1956)	101 7/8 (2588)	125 (3176)	149 (3786)	173 (4396)
Maximum O/S dimension of case back to front (includes bumper)	72 (1829)	72 (1829)	72 (1829)	72 (1829)	72 (1829)
Front of splashguard to O/S edge of front base rail	1 5/8 (41)	1 5/8 (41)	1 5/8 (41)	1 5/8 (41)	1 5/8 (41)
Front of case to O/S edge of front base rail	13 1/8 (333)	13 1/8 (333)	13 1/8 (333)	13 1/8 (333)	13 1/8 (333)
Back of case to O/S edge of front base rail	58 7/8 (1495)	58 7/8 (1495)	58 7/8 (1495)	58 7/8 (1495)	58 7/8 (1495)
Width of base rail	1 7/8 (48)	1 7/8 (48)	1 7/8 (48)	1 7/8 (48)	1 7/8 (48)
(D) Length of Canopy	66 1/8 (1680)	66 1/8 (1680)	90 1/8 (2289)	114 1/8 (2899)	138 1/8 (3508)
Width of Canopy	18 1/8 (460)	18 1/8 (460)	18 1/8 (460)	18 1/8 (460)	18 1/8 (460)
Electrical Service  (Electrical Field Wiring connection point)					
Center of Electrical service to O/S edge of front base rail	47 (1194)	47 (1194)	47 (1194)	47 (1194)	47 (1194)
Left end of case to center of knockout	27 (686)	27 (686)	27 (686)	27 (686)	27 (686)
Right end of case to center of knockout	69 (1753)	93 (2362)	117 (2972)	141 (3581)	165 (4191)
Waste Outlets 					
(C) LH End of case to the center of waste outlet	48 (1219)	78 (1981)	102 (2591)	84 (2134)	96 (2438)
Center of front waste outlet to outside of front base rail	8 7/8 (225)	8 7/8 (225)	8 7/8 (225)	8 7/8 (225)	8 7/8 (225)
Center of back waste outlet to outside of front base rail	40 1/8 (1019)	40 1/8 (1019)	40 1/8 (1019)	40 1/8 (1019)	40 1/8 (1019)
Schedule 40 PVC drip pipe	1 1/2 (38)	1 1/2 (38)	1 1/2 (38)	1 1/2 (38)	1 1/2 (38)
Refrigeration Outlet 					
LH end of case to center of refrigeration outlet	22 (559)	22 (559)	22 (559)	22 (559)	22 (559)
RH end of case to center of refrigeration outlet	74 (1880)	98 (2489)	122 (3099)	146 (3708)	170 (4318)

RI2
Delicatessen

Dimensions shown as inches and (mm).

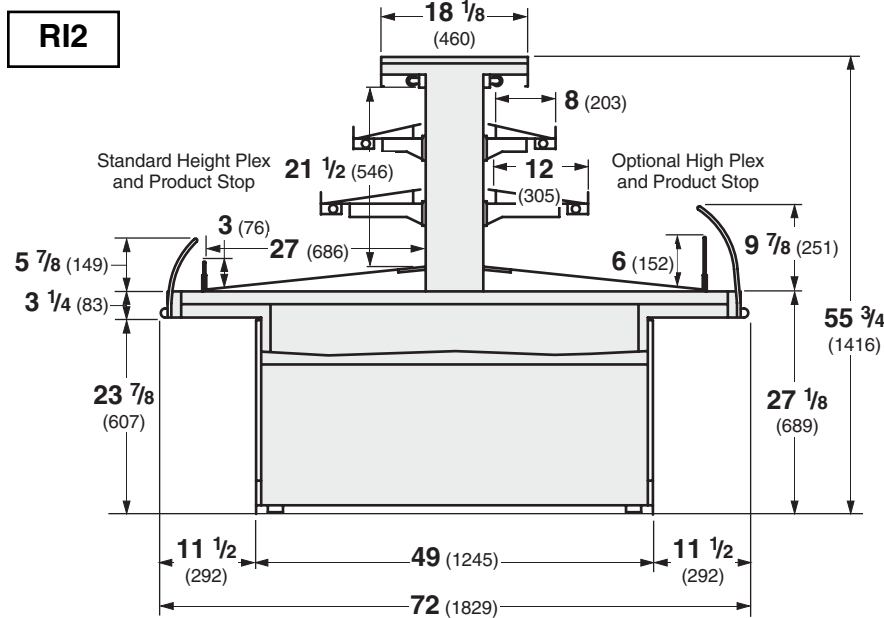

NSF® Certification

This merchandiser is manufactured to meet ANSI/NSF® (National Sanitation Foundation) Standard #7 requirements for construction, materials & cleanability.

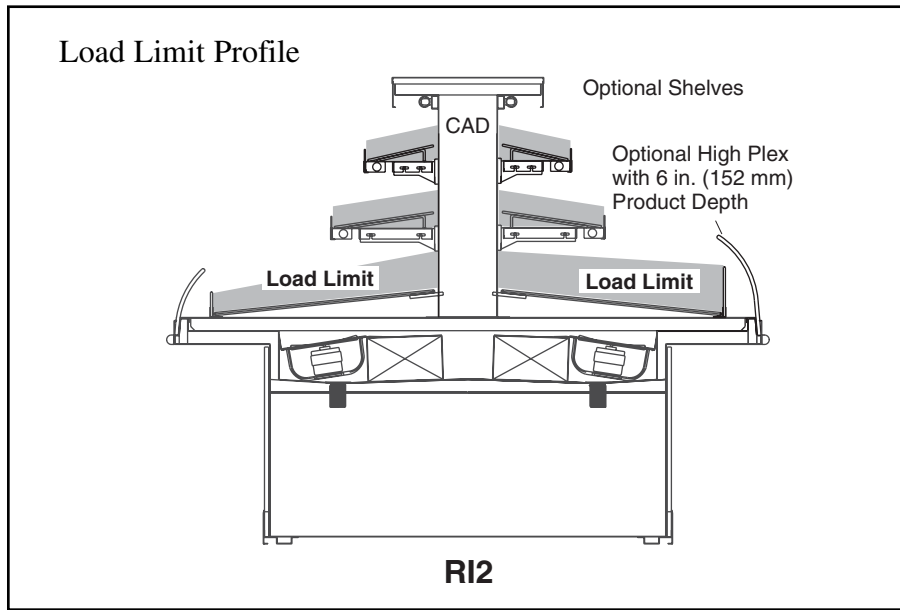

Cases may not function properly if they are loaded above load limits.

Air flow between the shelves, from the Center Air Discharge (CAD) to the return, must be maintained at all times for optimum operating efficiency and to prolong product shelf life. At no time should merchandisers be stocked beyond the load limits indicated.

REFRIGERATION DATA

Note: This data is based on store temperature and humidity that does not exceed 75°F and 55% R.H.

	RI2
Discharge Air (°F)	27
Evaporator (°F)	20
Unit Sizing (°F)	18
Btu/hr/ft[‡]	
LIT & UNLIT SHELVES	RI2
Parallel	1444
Conventional	1575

[‡]Optional energy efficient motors reduce the refrigeration load by 55 Btu/hr/ft.

DEFROST DATA

	RI2
Frequency (hr)	4
Defrost Water (lb/ft/day)	10
<i>(± 15% based on case configuration and product loading.)</i>	
OFFTIME	RI2
Time Terminated (minutes)	20

ELECTRIC OR GAS Not Recommended

CONVENTIONAL CONTROLS

Low Pressure Backup Control	
	RI2
CI/CO*	14°F / 4°F
Indoor Unit Only, Pressure Defrost Termination*	
	48°F

*Use a Temperature Pressure Chart to determine PSIG conversions.

Estimated Charge **		RI2
8 ft	1.7 lb 27 oz	0.8 kg
10 ft	2.1 lb 34 oz	1.0 kg
12 ft	2.5 lb 40 oz	1.1 kg
14 ft	3.1 lb 50 oz	1.4 kg
16 ft	3.7 lb 59 oz	1.7 kg

**This is an average for all refrigerant types. Actual refrigerant charge may vary by approximately half a pound.

RI2

Delicatessen

Electrical Data

			8 ft	10 ft	12 ft	14 ft	16 ft					
Number of Fans – 12W			4	6	8	10	12					
			Amperes					Watts				
			8 ft	10 ft	12 ft	14 ft	16 ft	8 ft	10 ft	12 ft	14 ft	16 ft
Evaporator Fan												
120V	60Hz	Standard	2.60	3.90	5.20	6.50	7.80	200	300	400	500	600
120V	50Hz	Standard	3.00	4.50	6.00	7.50	9.00	228	342	456	570	684
230V	60Hz	Export	NA	NA	NA	NA	NA	NA	NA	NA	NA	NA
230V	50Hz	Export	NA	NA	NA	NA	NA	NA	NA	NA	NA	NA
120V	60Hz	Energy Efficient	1.20	1.80	2.40	3.00	3.60	72	108	144	180	216
230V	60Hz	Energy Efficient	NA	NA	NA	NA	NA	NA	NA	NA	NA	NA
Anti-sweat Heaters												
120V	50/60Hz	Standard	0.70	0.70	0.90	1.10	1.30	84	84	108	132	156
230V	50/60Hz	Export	NA	NA	NA	NA	NA	NA	NA	NA	NA	NA
Minimum Circuit Ampacity (MCA)												
120V	60Hz	Standard	3.97	5.27	6.90	8.53	10.17					
120V	50Hz	Standard	3.81	5.31	6.98	8.66	10.33					
230V	60Hz	Export	NA	NA	NA	NA	NA					
230V	50Hz	Export	NA	NA	NA	NA	NA					
120V	60Hz	Energy Efficient	2.01	2.61	3.38	4.16	4.93					
230V	60Hz	Energy Efficient	NA	NA	NA	NA	NA					
Maximum Over Current Protection 120V			20	20	20	20	20					
Maximum Over Current Protection 230V			NA	NA	NA	NA	NA					
Standard Lighting												
1 Row Canopy			0.49	0.49	0.98	0.98	1.44	59	59	118	118	173
Optional Lighting												
1 Row of Ledge			1.67	2.00	2.33	2.67	3.00	200	240	280	320	360
Optional Shelf Lighting												
1 Row of Shelves			0.82	0.82	1.12	1.35	1.65	98	98	134	162	198
2 Rows of Shelves			1.63	1.63	2.23	2.70	3.30	196	196	268	324	396

115V Lighting Circuit Total = Standard Lighting + Total Optional Lighting + Optional Shelf Lighting

Product Data

RI28

<i>Recommended Usable Cube</i> ¹ (Cu Ft/Case)	34.15 ft ³ /case (0.97 m ³ /case)
<i>AHRI Total Display Area</i> ² (Sq Ft/Case)	40.10 ft ² /case (3.73 m ² /case)
<i>Shelf Area</i> ³ (Sq Ft/Case)	66.64 ft ² /case (6.19 m ² /case)

RI210

<i>Recommended Usable Cube</i> ¹ (Cu Ft/Case)	42.69 ft ³ /case (1.21 m ³ /case)
<i>AHRI Total Display Area</i> ² (Sq Ft/Case)	50.13 ft ² /case (4.66 m ² /case)
<i>Shelf Area</i> ³ (Sq Ft/Case)	83.30 ft ² /case (7.74 m ² /case)

RI212

<i>Recommended Usable Cube</i> ¹ (Cu Ft/Case)	51.23 ft ³ /case (1.45 m ³ /case)
<i>AHRI Total Display Area</i> ² (Sq Ft/Case)	60.15 ft ² /case (5.59 m ² /case)
<i>Shelf Area</i> ³ (Sq Ft/Case)	99.96 ft ² /case (9.29 m ² /case)

RI214

<i>Recommended Usable Cube</i> ¹ (Cu Ft/Case)	59.77 ft ³ /case (1.69 m ³ /case)
<i>AHRI Total Display Area</i> ² (Sq Ft/Case)	70.18 ft ² /case (6.52 m ² /case)
<i>Shelf Area</i> ³ (Sq Ft/Case)	116.62 ft ² /case (10.83 m ² /case)

RI216

<i>Recommended Usable Cube</i> ¹ (Cu Ft/Case)	68.30 ft ³ /case (1.93 m ³ /case)
<i>AHRI Total Display Area</i> ² (Sq Ft/Case)	80.20 ft ² /case (7.45 m ² /case)
<i>Shelf Area</i> ³ (Sq Ft/Case)	133.28 ft ² /case (12.38 m ² /case)

¹ AHRI Refrigerated Volume less shelving and other unusable space: Refrigerated Volume / Unit of Length, ft³/ft [m³/m]

² Computed using AHRI 1200 standard methodology: Total Display Area, ft² [m²] / Unit of Length, ft [m]

³ Shelf surface area is composed of bottom deck plus standard shelf complement, as shown in the Hussmann **Product Reference Guide**. The standard shelf complement for this model is (1) row of 8-inch shelf, (1) row of 12-inch shelf.

ESTIMATED SHIPPING WEIGHT ⁴

Case	8 ft	10 ft	12 ft	14 ft	16 ft	End
lb (kg)	1200 (544)	1400 (635)	1500 (680)	1700 (771)	1900 (862)	NA

⁴ Actual weights will vary according to optional kits included.

Fan Wiring Offtime Defrost

4, 6, 8, 10 & 12 Fans

- 8 ft — 4 Fans
- 10 ft — 6 Fans
- 12 ft — 8 Fans
- 14 ft — 10 Fans
- 16 ft — 12 Fans

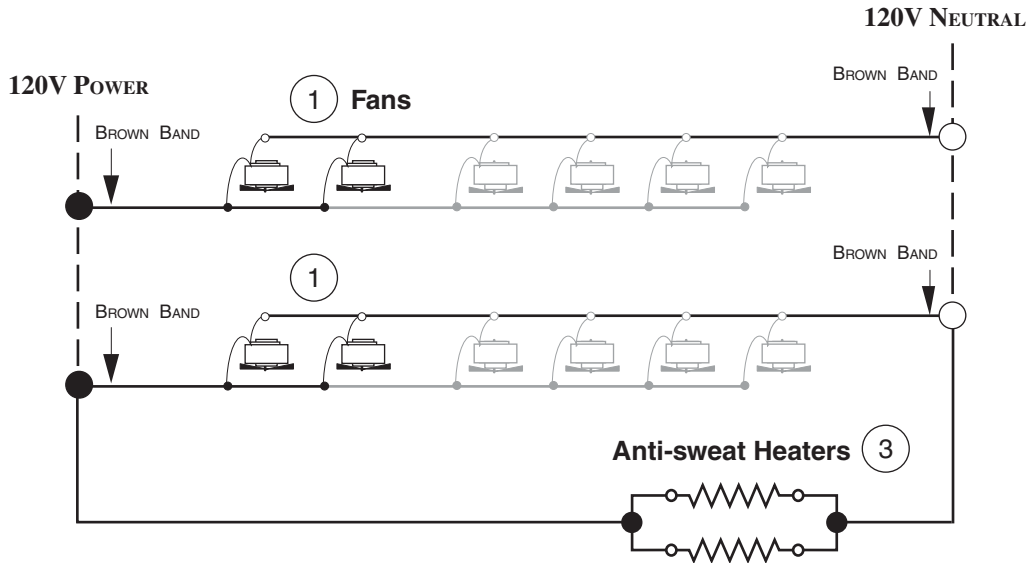

Refrigeration Thermostat



WARNING

All components must have mechanical ground, and the merchandiser must be grounded.

CIRCLED NUMBERS = PARTS LIST ITEM NUMBERS

R = Red Y = Yellow G = Green BL = Blue B = Black W = White

● = 120V POWER ○ = 120V NEUTRAL ⊥ = FIELD GROUND ≡ = CASE GROUND

Standard Lighting — 1 Row Canopy

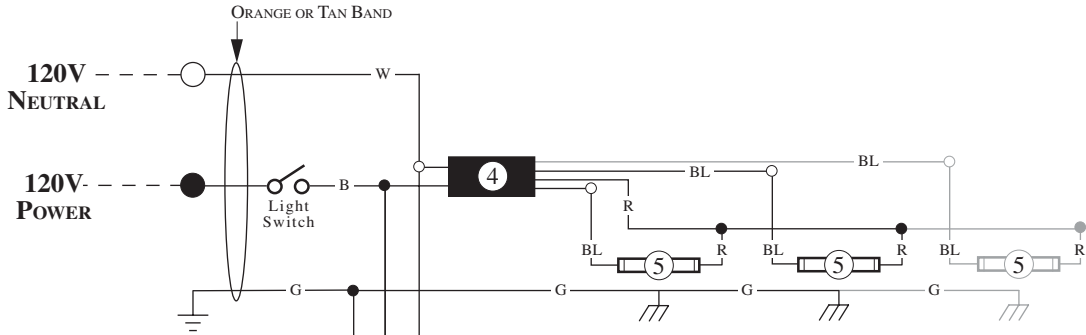

Lighted Shelf Wiring

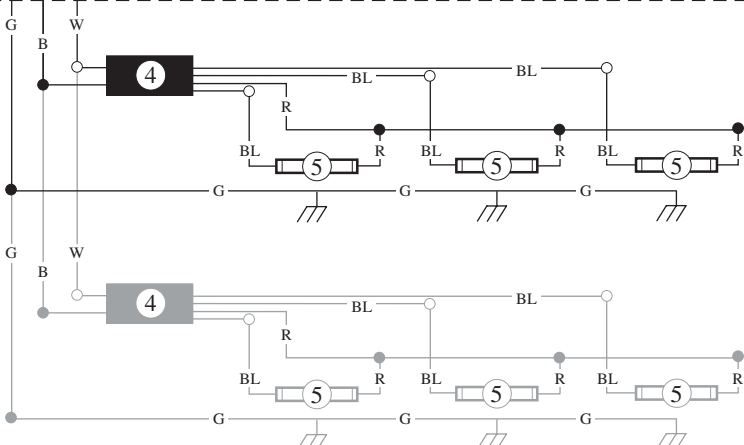

Typical Shelf Ballast Wiring

Maximum lamps per ballast is three (3).
 Different shelf configurations and different case lengths will have more shelf ballasts.

Optional Ledge Light Circuit

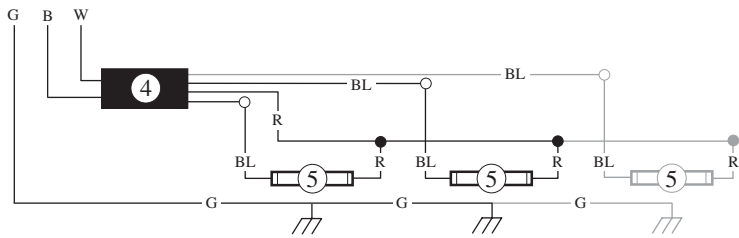

WARNING

All components must have mechanical ground, and the merchandiser must be grounded.

CIRCLED NUMBERS = PARTS LIST ITEM NUMBERS

R = Red Y = Yellow G = Green BL = Blue B = Black W = White

● = 120V POWER ○ = 120V NEUTRAL ⊥ = FIELD GROUND ≡ = CASE GROUND