

We reserve the right to change or revise specifications and product design in connection with any feature of our products. Such changes do not entitle the buyer to corresponding changes, improvements, additions or replacements for equipment previously sold or shipped.

Item	Part #	Description	Wiring Item #	Item	Part #	Description	Wiring Item #
FAN ASSEMBLIES AND THERMOSTATS				HEATERS			
8 Ft, 12 Ft, 14 Ft & 16 Ft				C.	0447688	Anti-Sweat Heater (HE.4850682)	(3)
A.	12W Standard Energy Efficient	Fan Assembly (1)		LAMPS AND BALLASTS			
	0477655	Fan Motor, Evaporator (MO.4410546)		D.	0447683	Ballast, Electronic 2 Lamps (BA.4440811)	(4)
	0376413	Fan Blade (FB.0376413) embossing toward motor		E.		Fluorescent Lamp <i>Replace with like fixtures</i>	(5)
B.	Optional Adjustable Refrigeration Thermostat (2)						
	0448347	(CT.4481631)					

Note: Rev. E makes energy efficient fans standard, adds DOE 2012 compliance. Other changes marked by bar, underline or circle.



Engineering Plan Views

PHYSICAL DATA

Merchandiser Drip Pipe (in.)	1 1/2
Merchandiser Liquid Line (in.)	3/8
Merchandiser Suction Line (in.)	5/8

Dimensions shown as inches and (mm).

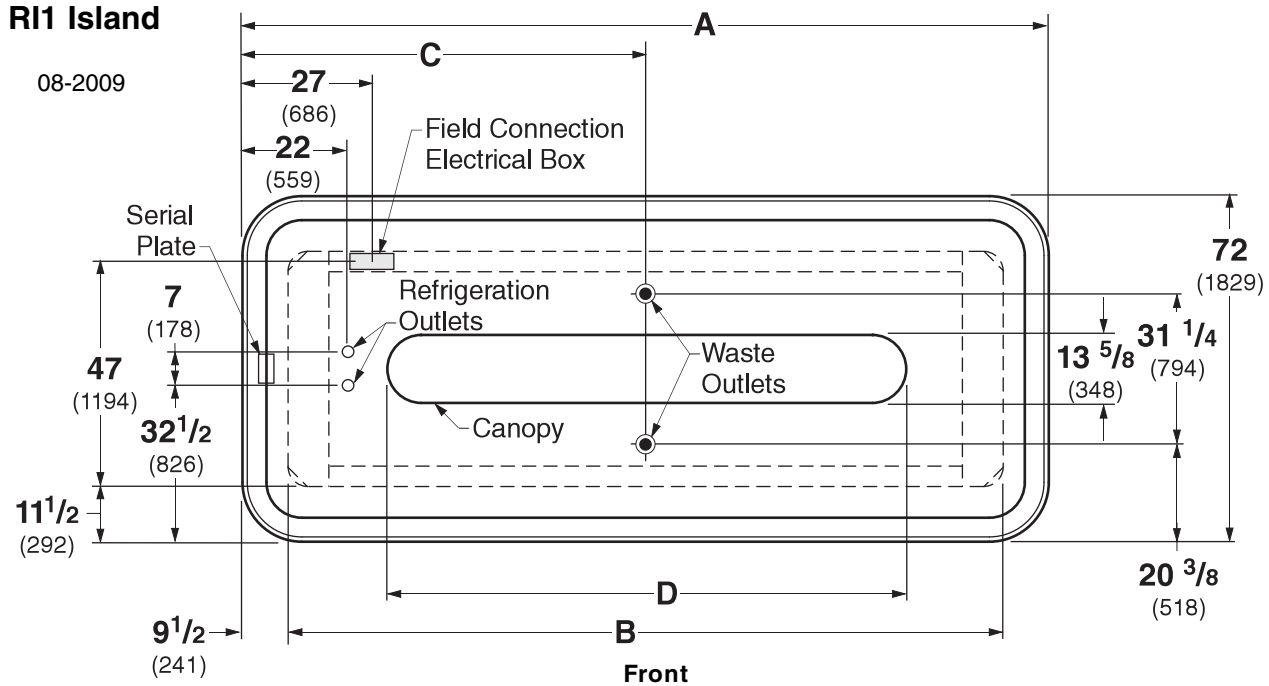

	8 ft	12 ft	14 ft	16 ft
General				
(A) Overall Case Length	96 (2438)	144 (3658)	168 (4267)	192 (4877)
(B) Base Length	77 (1956)	125 (3176)	149 (3786)	173 (4394)
Maximum O/S dimension of case back to front (includes bumper)	72 (1829)	72 (1829)	72 (1829)	72 (1829)
Front of splashguard to O/S edge of front base rail	1 5/8 (41)	1 5/8 (41)	1 5/8 (41)	1 5/8 (41)
Front of case to O/S edge of front base rail	13 1/8 (333)	13 1/8 (333)	13 1/8 (333)	13 1/8 (333)
Back of case to O/S edge of front base rail	58 7/8 (1495)	58 7/8 (1495)	58 7/8 (1495)	58 7/8 (1495)
Width of base rail	1 7/8 (48)	1 7/8 (48)	1 7/8 (48)	1 7/8 (48)
(D) Length of Canopy	61 5/8 (1565)	85 5/8 (2175)	109 5/8 (2784)	133 5/8 (3394)
Width of Canopy	13 5/8 (346)	13 5/8 (346)	13 5/8 (346)	13 5/8 (346)
Electrical Service (Electrical Field Wiring connection point)				
Center of Electrical service to O/S edge of front base rail	47 (1194)	47 (1194)	47 (1194)	47 (1194)
Left end of case to center of field connection box	27 (686)	27 (686)	27 (686)	27 (686)
Right end of case to center of field connection box	69 (1753)	117 (2972)	141 (3581)	165 (4191)
Waste Outlets				
(C) LH End of case to the center of waste outlet	48 (1219)	102 (2591)	84 (2134)	96 (2438)
Center of front waste outlet to outside of front base	8 7/8 (225)	8 7/8 (225)	8 7/8 (225)	8 7/8 (225)
Center of back waste outlet to outside of front base	40 1/8 (1019)	40 1/8 (1019)	40 1/8 (1019)	40 1/8 (1019)
Schedule 40 PVC drip pipe	1 1/2 (38)	1 1/2 (38)	1 1/2 (38)	1 1/2 (38)
Refrigeration Outlet				
LH end of case to center of refrigeration outlet	22 (559)	22 (559)	22 (559)	22 (559)
RH end of case to center of refrigeration outlet	74 (1880)	122 (3099)	146 (3708)	170 (4318)

Single Deck Island, 1 Display Level



Husmann refrigerated merchandisers configured for sale for use in the United States meet or surpass the requirements of the DOE 2012 energy efficiency standards.



Dimensions shown as inches and (mm).

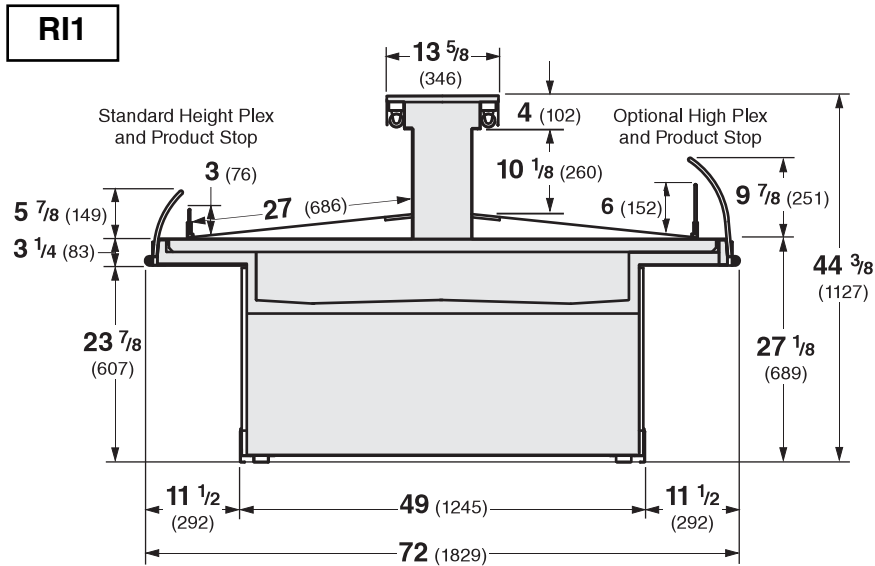

NSF Certification

This merchandiser model is manufactured to meet NSF/ANSI (National Sanitation Foundation) Standard #7 requirements for construction, materials & cleanability.

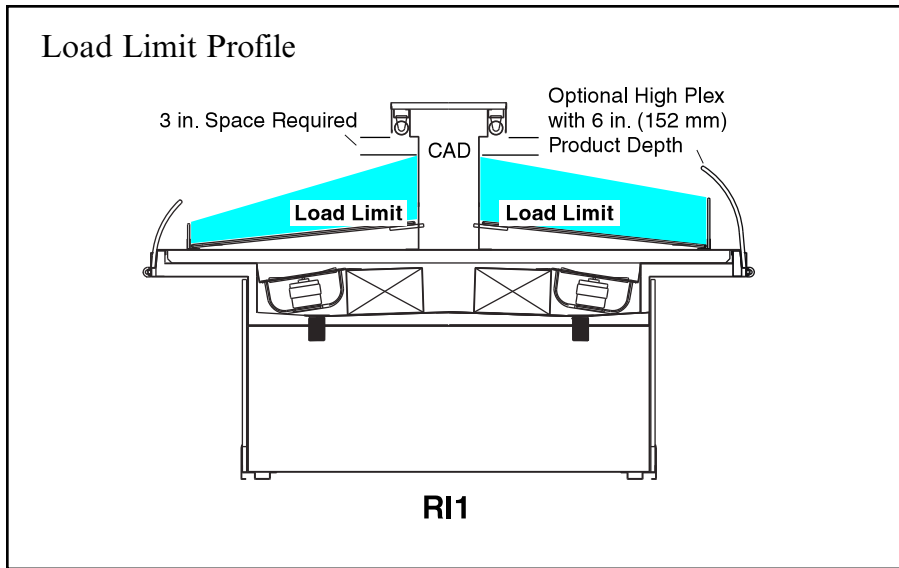

Cases may not function properly if they are loaded above load limits.

Air flow between the shelves, from the Center Air Discharge (CAD) to the return, must be maintained at all times for optimum operating efficiency and to prolong product shelf life. At no time should merchandisers be stocked beyond the load limits indicated.

REFRIGERATION DATA

Note: This data is based on store temperature and humidity that does not exceed 75°F and 55% R.H.

	RI1
Discharge Air (°F)	27
Evaporator (°F)	15
Unit Sizing (°F)	13
<i>Btu/hr/ft</i>	RI1
Parallel	1205
Conventional	1320

DEFROST DATA

	RI1
Frequency (hr)	4
Defrost Water (lb/ft/day)	9
(± 15% based on case configuration and product loading).	

<i>OFFTIME</i>	RI1
Time Terminated (minutes)	20

ELECTRIC OR GAS Not Recommended

CONVENTIONAL CONTROLS

Low Pressure Backup Control	RI1
CI/CO*	8°F / -2°F
Indoor Unit Only, Pressure Defrost Termination*	48°F

*Use a Temperature Pressure Chart to determine PSIG conversions.

Estimated Charge **	RI1
8 ft	1.7 lb 27 oz 0.8 kg
12 ft	2.5 lb 40 oz 1.1 kg
14 ft	3.1 lb 50 oz 1.4 kg
16 ft	3.7 lb 59 oz 1.7 kg

**This is an average for all refrigerant types. Actual refrigerant charge may vary by approximately half a pound (8 oz/0.2 kg).

RI1

Delicatessen

Electrical Data

			8 ft	12 ft	14 ft	16 ft				
Number of Fans – 12W			4	8	10	12				
			Amperes				Watts			
			8 ft	12 ft	14 ft	16 ft	8 ft	12 ft	14 ft	16 ft
Evaporator Fan										
120V	50/60Hz	Standard Energy Efficient	1.20	2.40	3.00	3.60	72	144	180	216
230V	50/60Hz	Standard Energy Efficient	NA	NA	NA	NA	NA	NA	NA	NA
230V	60Hz	Export	NA	NA	NA	NA	NA	NA	NA	NA
230V	50Hz	Export	NA	NA	NA	NA	NA	NA	NA	NA
Anti-sweat Heaters										
120V	50/60Hz	Standard	1.00	1.33	1.67	2.00	120	160	200	240
230V	50/60Hz	Export	NA	NA	NA	NA	NA	NA	NA	NA
Minimum Circuit Ampacity (MCA)										
120V	50/60Hz	Standard Energy Efficient	1.92	3.30	4.07	4.84				
230V	50/60Hz	Standard Energy Efficient	NA	NA	NA	NA				
230V	60Hz	Export	NA	NA	NA	NA				
230V	50Hz	Export	NA	NA	NA	NA				
Maximum Over Current Protection 120V			20	20	20	20				
Maximum Over Current Protection 230V			NA	NA	NA	NA				

ONLY LIGHTING CONFIGURATIONS THAT ARE COMPLIANT WITH THE U.S. DEPT. OF ENERGY (DOE) 2012 REGULATION ARE AVAILABLE FOR SALE FOR USE IN THE U.S.A.

Standard Lighting										
1 Row Canopy			0.80	1.20	1.60	2.00	96	144	192	240
Optional Lighting										
1 Row of Ledge			1.67	2.33	2.67	3.00	200	280	320	360
Optional Shelf Lighting										
None										

115V Lighting Circuit Total = Standard Lighting + Total Optional Lighting + Optional Shelf Lighting

Product Data

RI18

<i>Recommended Usable Cube</i> ¹ (Cu Ft/Case)	18.00 ft ³ /case (0.51 m ³ /case)
<i>AHRI Total Display Area</i> ² (Sq Ft/Case)	45.28 ft ² /case (4.21 m ² /case)
<i>Shelf Area</i> ³ (Sq Ft/Case)	36.00 ft ² /case (3.34 m ² /case)

RI112

<i>Recommended Usable Cube</i> ¹ (Cu Ft/Case)	27.00 ft ³ /case (0.76 m ³ /case)
<i>AHRI Total Display Area</i> ² (Sq Ft/Case)	67.92 ft ² /case (6.31 m ² /case)
<i>Shelf Area</i> ³ (Sq Ft/Case)	54.00 ft ² /case (5.02 m ² /case)

RI114

<i>Recommended Usable Cube</i> ¹ (Cu Ft/Case)	31.50 ft ³ /case (0.89 m ³ /case)
<i>AHRI Total Display Area</i> ² (Sq Ft/Case)	79.24 ft ² /case (7.36 m ² /case)
<i>Shelf Area</i> ³ (Sq Ft/Case)	63.00 ft ² /case (5.85 m ² /case)

RI116

<i>Recommended Usable Cube</i> ¹ (Cu Ft/Case)	36.00 ft ³ /case (1.02 m ³ /case)
<i>AHRI Total Display Area</i> ² (Sq Ft/Case)	90.56 ft ² /case (8.41 m ² /case)
<i>Shelf Area</i> ³ (Sq Ft/Case)	72.00 ft ² /case (6.69 m ² /case)

¹ AHRI Refrigerated Volume less shelving and other unusable space: Refrigerated Volume / Unit of Length, ft³/ft [m³/m]

² Computed using AHRI 1200 standard methodology: Total Display Area, ft² [m²] / Unit of Length, ft [m]

³ Shelf surface area is composed of bottom deck plus standard shelf complement, as shown in the Hussmann *Product Reference Guide*. The standard shelf complement for this model is none.

ESTIMATED SHIPPING WEIGHT ⁴

Case	8 ft	12 ft	14 ft	16 ft	End
lb (kg)	1100 (499)	1400 (635)	1500 (680)	1600 (726)	NA

⁴ Actual weights will vary according to optional kits included.

Fan Wiring Offtime Defrost

4, 8, 10 & 12 Fans

- 8 ft — 4 Fans
- 12 ft — 8 Fans
- 14 ft — 10 Fans
- 16 ft — 12 Fans

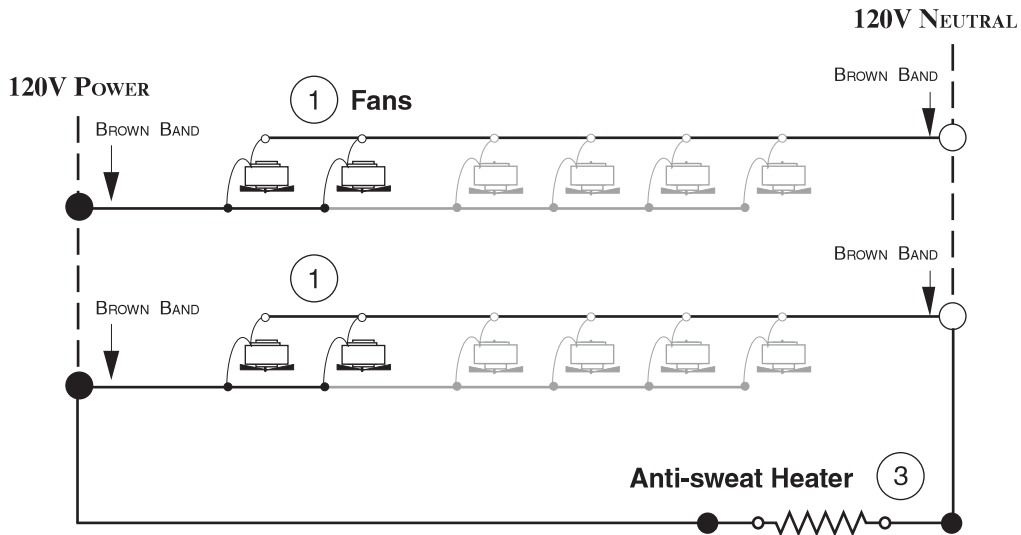

Refrigeration Thermostat



WARNING

All components must have mechanical ground, and the merchandiser must be grounded.

CIRCLED NUMBERS = PARTS LIST ITEM NUMBERS

R = Red Y = Yellow G = Green BL = Blue B = Black W = White

● = 120V POWER ○ = 120V NEUTRAL ⊥ = FIELD GROUND ≡ = CASE GROUND

Standard Lighting — 1 Row Canopy

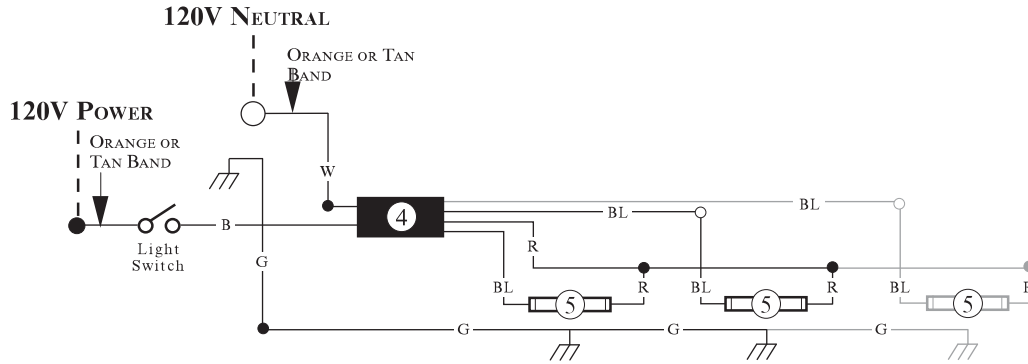

Optional Ledge Light Circuit

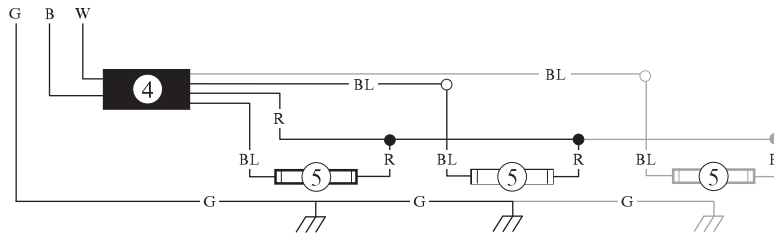

WARNING

All components must have mechanical ground, and the merchandiser must be grounded.

CIRCLED NUMBERS = PARTS LIST ITEM NUMBERS

R = Red Y = Yellow G = Green BL = Blue B = Black W = White

● = 120V POWER ○ = 120V NEUTRAL ⊥ = FIELD GROUND ≡ = CASE GROUND