

This display merchandiser is not for the display of potentially hazardous foods.

We reserve the right to change or revise specifications and product design in connection with any feature of our products. Such changes do not entitle the buyer to corresponding changes, improvements, additions or replacements for equipment previously sold or shipped.

Item	Part #	Description	Wiring Item #	Item	Part #	Description	Wiring Item #
FAN ASSEMBLIES				THERMOSTATS			
8 Ft & 12 Ft							
A.	4W Standard Fan Assembly		(1)	B.	Optional Adjustable Refrigeration Thermostat		(2)
	0392457	Fan Motor, Evaporator (MO.4410101)					
	0464847	Fan Blade (FB.4780649)					
	4W Energy Efficient Fan Assembly		(1)	LAMPS AND BALLASTS			
	0477653	Fan Motor, Evaporator (MO.4410544)		None			
	0464847	Fan Blade (FB.4780649)					
6 Ft Only							
A.	4W Standard Fan Assembly		(1)				
	0392457	Fan Motor, Evaporator (MO.4410101)					
	0252116	Fan Blade (FB.4780611)					
	4W Energy Efficient Fan Assembly		(1)				
	0477653	Fan Motor, Evaporator (MO.4410544)					
	0252116	Fan Blade (FB.4780611)					

Note: Revision F adds 6 Ft model. Other changes marked by bar, underline or circle.



Engineering Plan Views

PHYSICAL DATA	
Merchandiser Drip Pipe (in.)	1 1/4
Merchandiser Liquid Line (in.)	3/8
Merchandiser Suction Line (in.)	5/8

Bulk Produce

09-2005

Dimensions shown as in. and (mm).

P1X50-EP

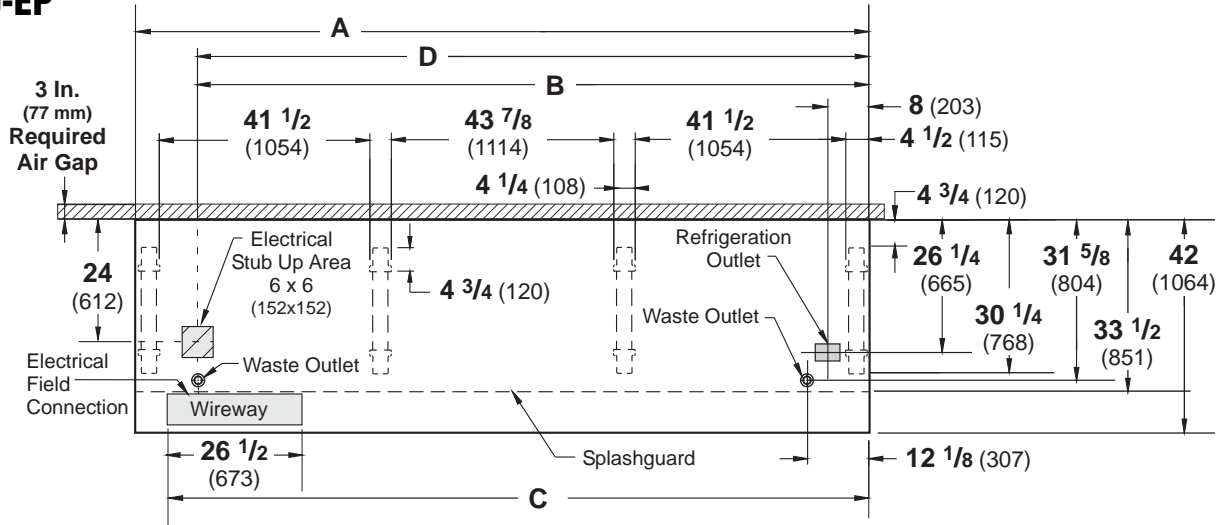

NOTE: Case-to-Case Electrical Connections are made IN FRONT OF SPLASHGUARD.

FRONT

	6 ft	8 ft	12 ft
General			
(A) Case Length (<i>without ends or partitions</i>) (Each end and insulated partition adds 1 1/2 in. (38 mm) to case line up.) Maximum O/S dimension of case back to front (includes bumper)	72 3/8 (1838)	96 3/8 (2448)	144 1/2 (3670)
Back of case to front of splashguard	42 (1064)	42 (1064)	42 (1064)
Back of case to O/S edge of front leg	33 1/2 (851)	33 1/2 (851)	33 1/2 (851)
Distance between edges of external legs and center legs	30 1/4 (768)	30 1/4 (768)	30 1/4 (768)
Distance between edges of center legs	29 1/2 (750)	41 1/2 (1054)	41 1/2 (1054)
Distance between front legs and splashguard	NA	NA	43 7/8 (1114)
	2 3/4 (70)	2 3/4 (70)	2 3/4 (70)
Electrical Service <input checked="" type="checkbox"/> (<i>Electrical Field Wiring connection point</i>)			
(B) RH End of case to center of stub up area Back of case to center of stub up area Length of electrical wireway <input type="checkbox"/> Wireway	60 1/4 (1530) 24 (612) 26 1/2 (673)	84 1/4 (2140) 24 (612) 26 1/2 (673)	132 3/8 (3363) 24 (612) 26 1/2 (673)
(C) RH End of case to LH end of wireway	66 1/8 (1680)	90 1/8 (2289)	138 1/4 (3511)
Waste Outlets (<i>One each end</i>) <input checked="" type="checkbox"/>			
(D) RH End of case to the center of LH waste outlet RH End of case to the center of RH waste outlet Back O/S of case to center of waste outlets Schedule 40 PVC drip pipe	60 1/4 (1530) 12 1/8 (307) 31 5/8 (804) 1 1/4 (32)	84 1/4 (2140) 12 1/8 (307) 31 5/8 (804) 1 1/4 (32)	132 3/8 (3363) 12 1/8 (307) 31 5/8 (804) 1 1/4 (32)
Refrigeration Outlet <input type="checkbox"/>			
Back of case to center of refrigeration outlet RH end of case to center of refrigeration outlet	26 1/4 (665) 8 (203)	26 1/4 (665) 8 (203)	26 1/4 (665) 8 (203)

Impact Excel P1X50-EP
Bulk Produce*

REFRIGERATION DATA

Note: This data is based on store temperature and humidity that does not exceed 75°F and 55% R.H.

	P1X50-EP
Discharge Air (°F)	31
Evaporator (°F)	28
Unit Sizing (°F)	26

	P1X50-EP
Btu/hr/ft[‡]	P1X50-EP
Parallel	559
Conventional	594

[‡] Optional energy efficient motors reduce the refrigeration load by 14 Btu/hr/ft.

DEFROST DATA

	P1X50-EP
Frequency (hr)	8
Defrost Water (lb/ft/day)	4

(± 15% based on case configuration and product loading).

	P1X50-EP
OFF TIME	P1X50-EP
Time (minutes)	35

ELECTRIC OR GAS Not Recommended

CONVENTIONAL CONTROLS

Low Pressure Backup Control	P1X50-EP
CI/CO*	21°F / 11°F

Indoor Unit Only, Pressure Defrost

Termination** 48°F

*Use a Temperature Pressure Chart to determine PSIG conversions.

	P1X50-EP			
Estimated Charge**				
6 ft	1.4 lb	22 oz		
8 ft	2.0 lb	32 oz		
12 ft	2.6 lb	42 oz		

**This is an average for all refrigerant types. Actual refrigerant charge may vary by approximately half a pound.

Dimensions shown as inches and (mm).

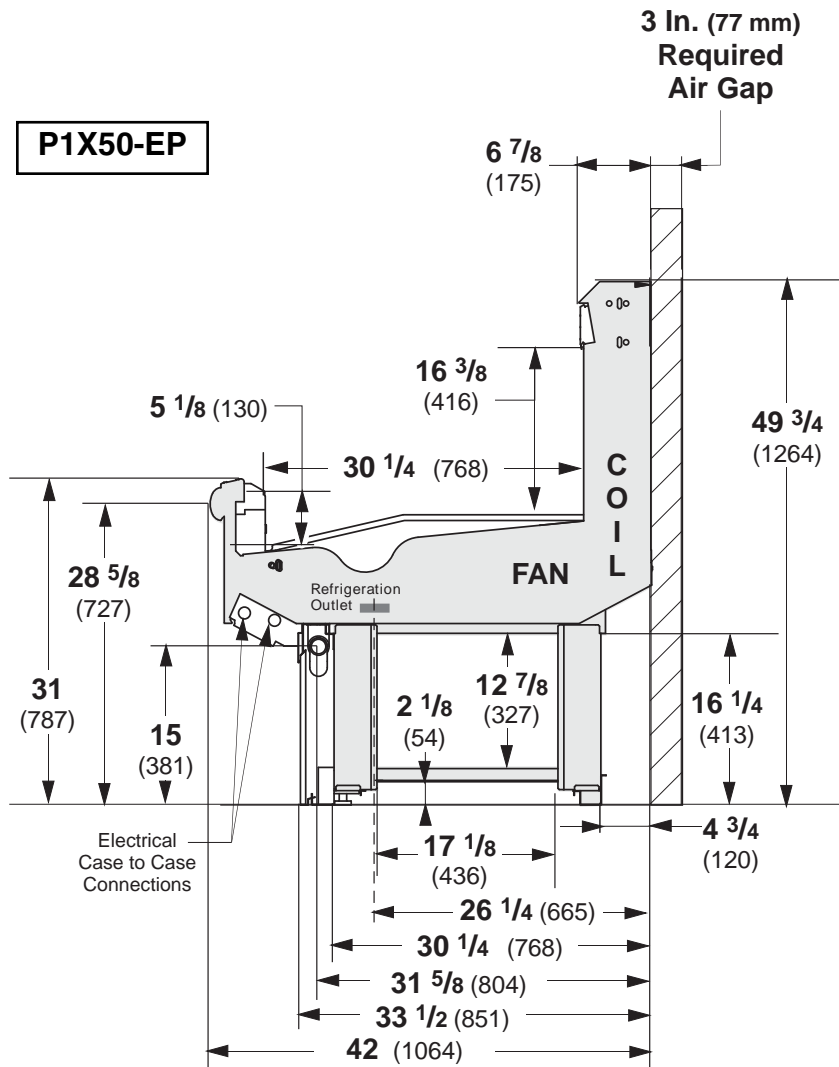

NSF Certification

This merchandiser model is manufactured to meet ANSI/NSF (National Sanitation Foundation) Standard #7 requirements for construction, materials & cleanability.

*As a Bulk Produce display refrigerator, it is not designed for critical temperature requirements. The merchandiser is labeled: "This display refrigerator is not for the display of potentially hazardous foods".

Impact Excel P1X50-EP Bulk Produce

Electrical Data

			6 ft	8 ft	12 ft			
Number of Fans—4W			2	2	3			
			Amperes			Watts		
			6 ft	8 ft	12 ft	6 ft	8 ft	12 ft
Evaporator Fan								
120V	60Hz	Standard	0.62	0.62	0.93	248	48	72
120V	50Hz	Standard	0.76	0.76	1.14	54	54	81
230V	60Hz	Export	0.30	0.30	0.45	48	48	72
230V	50Hz	Export	0.36	0.36	0.54	54	54	81
120V	60Hz	Energy Efficient	0.24	0.24	0.36	16	16	24
230V	60Hz	Energy Efficient	0.12	0.12	0.18	16	16	24
Minimum Circuit Ampacity								
120V	60Hz	Standard	0.82	0.82	1.13			
120V	50Hz	Standard	0.96	0.96	1.34			
230V	60Hz	Export	0.50	0.50	0.65			
230V	50Hz	Export	0.56	0.56	0.74			
120V	60Hz	Energy Efficient	0.44	0.44	0.56			
230V	60Hz	Energy Efficient	0.32	0.32	0.38			
Maximum Over Current Protection 120V			20	20	20			
Maximum Over Current Protection 230V			15	15	15			

Product Data

<i>Recommended Usable Cube</i> ¹ (Cu Ft/Ft)	1.75 ft ³ /ft (0.16 m ³ /m)
<i>AHRI Total Display Area</i> ² (Sq Ft/Ft)	2.80 ft ² /ft (0.85 m ² /m)
<i>Shelf Area</i> ³ (Sq Ft/Ft)	2.53 ft ² /ft (0.77 m ² /m)

¹ AHRI Refrigerated Volume less shelving and other unusable space: Refrigerated Volume/Unit of Length, ft³/ft [m³/m]

² Computed using AHRI 1200 standard methodology: Total Display Area, ft² [m²]/Unit of Length, ft [m]

³ Shelf surface area is composed of bottom deck plus standard shelf complement, as shown in the Hussmann *Product Reference Guide*. The standard shelf complement for this model is NONE.

ESTIMATED SHIPPING WEIGHT⁵

Case				Solid End
	6 ft	8 ft	12 ft	(each)
lb (kg)	700 (318)	900 (408)	1000 (454)	50 (23)

⁵ Actual weights will vary according to optional kits included.

**Fan Wiring
Offtime Defrost**

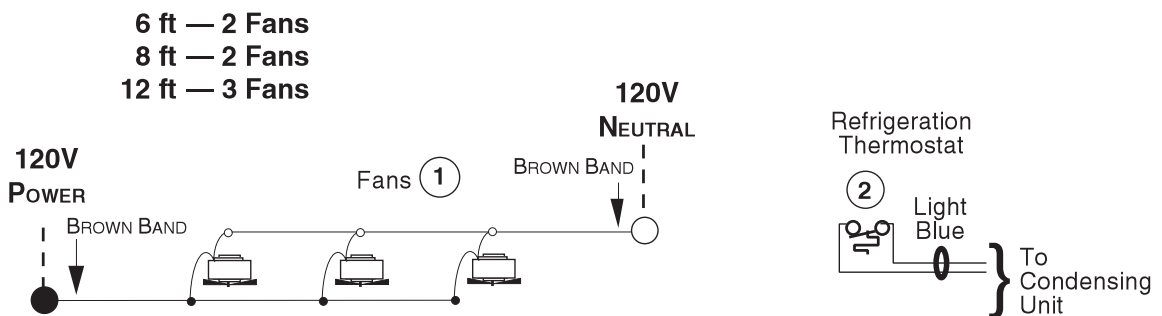

WARNING

All components must have mechanical ground, and the merchandiser must be grounded.

CIRCLED NUMBERS = PARTS LIST ITEM NUMBERS

● = 120V POWER ○ = 120V NEUTRAL