

- OPTION SHOWN:
• Lighted Facades
- NOT SHOWN
• Facade Arch
- NOT AVAILABLE
• Dry Goods Shelves
• Shelf Lamps
• Goose Neck Lamps
• Bump Out

WARNING
Terminal block NOT for case-to-case wire connection!

We reserve the right to change or revise specifications and product design in connection with any feature of our products. Such changes do not entitle the buyer to corresponding changes, improvements, additions or replacements for equipment previously sold or shipped.

Item	Part #	Description	Wiring Item #	ItemPart #	Qty	Description	Wiring Item #
FAN ASSEMBLIES, AND THERMOSTATS				HEATERS			
A.	12W Standard	Fan Assembly	(1)	H.	HE.4850346 (2)	Electric Defrost Heater – Front (208V)	(8)
	MO.4410103	Fan Motor, Evaporator			HE.4850358 (2)	Electric Defrost Heater – Rear (208V)	(8)
	FB.4780446	Fan Blade			HE.4850502 (2)	Electric Defrost Heater – End (208V)	(8)
	12W Optional Energy Efficient	Fan Assembly	(1)	I.	HE.4850240 (2)	Drain Pan Heater (120V)	(9)
	MO.4410546	Fan Motor, Evaporator				Electric & Kool Gas	
	FB.4780446	Fan Blade		J	HE.4850573	Flue Reheater (120V)	(10)
B.	CT.4440726	Standard Non-adjustable Defrost Thermostat	(2)	LED FIXTURES AND POWER SUPPLY			
C.		Optional Adjustable Refrigeration Thermostat	(3)	K.	EP.4481668	Power Supply	(10)
D.	CT.4440261	Defrost Limit Thermostat	(4)	L.	Door Lamp, LED		
E.	CT.4481296	Relay Control Thermostat or Fan and Anti-sweat Heater Thermostat	(5)		BU.4440875	3500K Center	(11)
					BU.4440877	4100K Center	(11)
					BU.4440876	3500K End	(12)
					BU.4440878	4100K End	(12)
RELAYS				M.	Facade Lamp, LED		(13)
F.	RL.4480238	Anti-Sweat Control Relay (120V)	(6)		BU.4441411	2900K 29.5 In. Length	
G.	RL.4480237	Fan Control Relay (208V)	(7)		BU.4441412	2900K 30.5 In. Length	

Refer to INNOVATOR REACH-IN GLASS DOOR INSTALLATION AND SERVICE manual, P/N 0425683, for Innovator and Innovator II door and frame replacement parts.

NOTE: For LED lighting parts contact your Husmann service representative at 1-800-922-1919. Please have your model and serial number available.

NOTE: Revision A is original issue.



**Engineering
Plan Views**

Reach-In
Narrow Island
Unitized End

**LifeLine Premier
RLNIE
Plan View
013010**

PHYSICAL DATA

Merchandiser Drip Pipe (in.)	1 1/4
Merchandiser Liquid Line (in.)	5/8
Merchandiser Suction Line (in.)	1 1/8



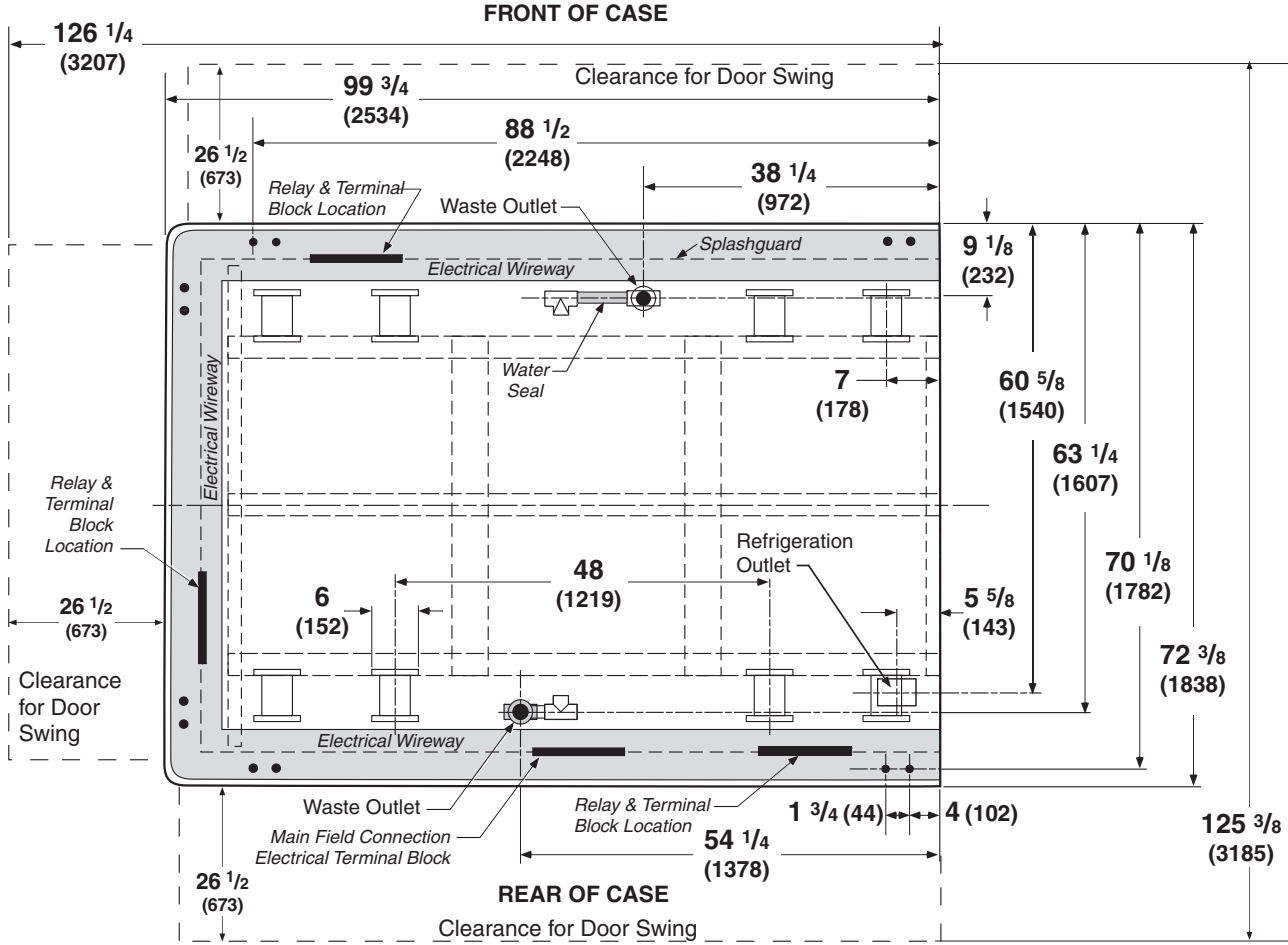

Dimensions shown as in. & (mm).



Base island merchandiser is shown above. Bump Out not available on island models. Refer to chart on Page 3 for detailed dimensional information on options.

**Plan View Dimensions for
LifeLine Premier Options**

LifeLine Premier RLNIE
With INNOVATOR Doors
Frozen Food & Ice Cream

Abbreviations: DG = Dry Goods section BO = Bump Out	RLNIE
General	
(A) Merchandiser Length	99 3/4 (2530)
Maximum O/S dimension of merchandiser back to front ***	72 3/8 (1837)
*** Includes bumper. Add 53 in. (1346 mm) for door swing.	
Width of skid rail	3 3/4 (95)
Width of Bottom Front Support	6 (152)
Stub-up area between front support and splashguard	9 (229)
Electrical Service* 	
(B) RH end of merchandiser to the center of nearest knockout	4 (102)
RH end of merchandiser to the center of LH knockout	88 1/2 (2248)
* NOTE: Electrical Field Wiring Connection Point is at terminal.	
Waste Outlet 	
(C) Right end of merchandiser to center of waste outlet	38 1/4 (972)
RH end of merchandiser to center of waste outlet in front of case	54 1/4 (1378)
Back O/S of merchandiser to center of waste outlet	63 1/4 (1607)
Water Seal 	
Edge of water seal to center of waste outlet	13 (330)
Outside diameter of drip piping	1 1/4 (32)
<i>Field installed water seal outlets, tees, and connectors are shipped with case.</i>	
Refrigeration Outlet 	
(D) RH end of merchandiser to center of RH refrigeration outlet	5 5/8 (142)
Back O/S of merchandiser to center of refrigeration outlet	60 5/8 (1541)
Outside bottom front supports from end of merchandiser	7 (178)
Center bottom front support from Centerline	48 (1219)

LifeLine Premier RLNIE

With INNOVATOR Doors
Frozen Food & Ice Cream

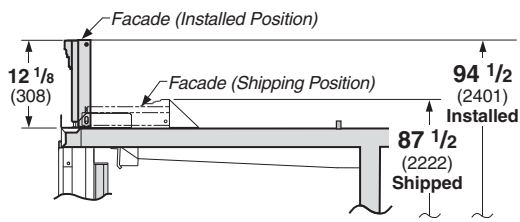

12 in. Straight Facade

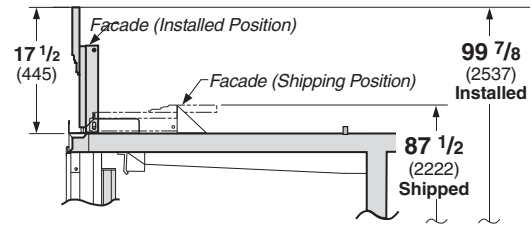

12 in. Arch Facade

Facade Options in Cross Section

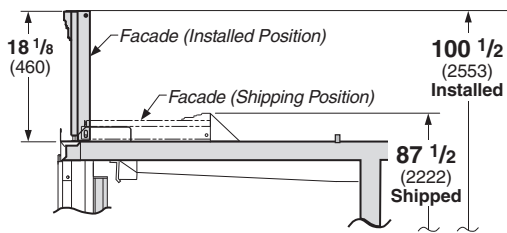

18 in. Straight Facade

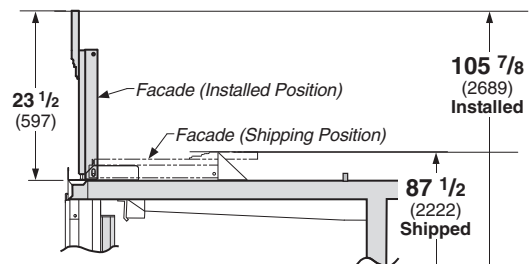

18 in. Arch Facade



LifeLine Premier Reach-in Narrow Island,
End and Center Unitized

Dimensions shown as in. & (mm).

LifeLine Premier RLNIE
With INNOVATOR Doors
Frozen Food & Ice Cream

**LifeLine
Premier
RLNIE**

**See Page 4
for alternate
facade heights.**

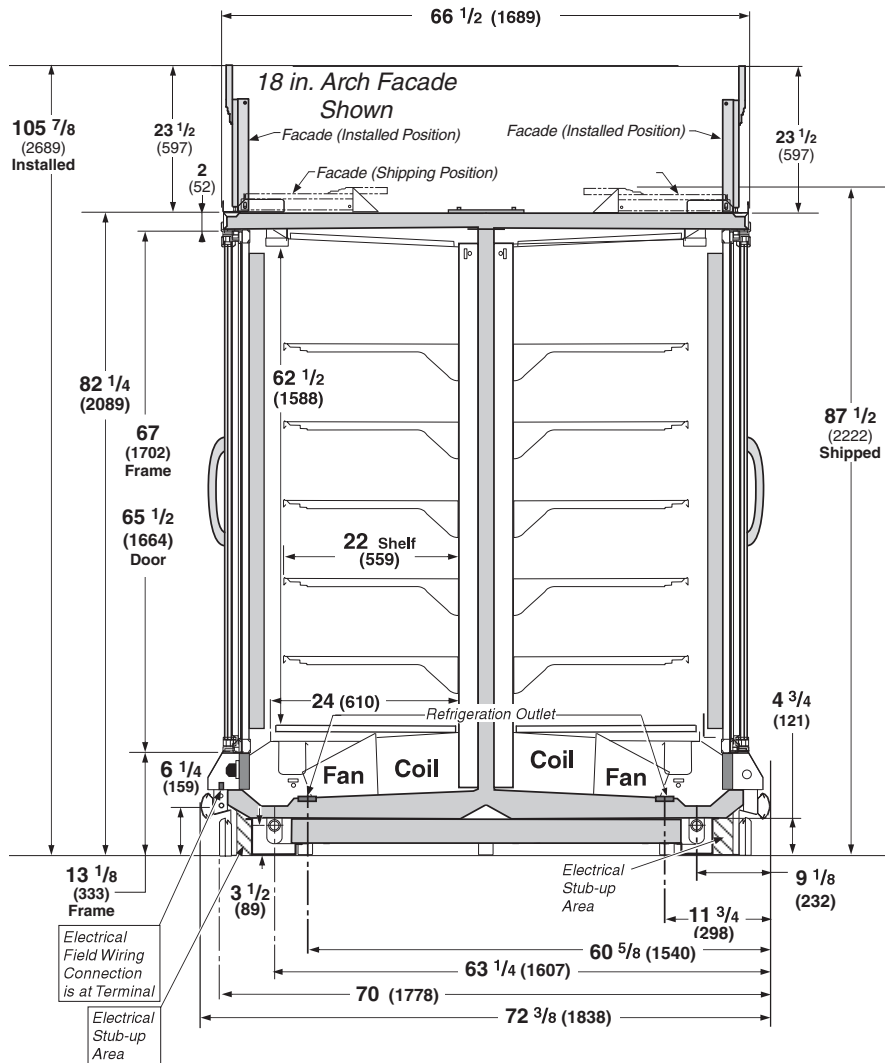

REFRIGERATION DATA

Note: This data is based on store temperature and humidity that does not exceed 75°F and 55% R.H.

	FF	IC
Discharge Air (°F)	0	-11
Evaporator (°F)	-11	-19
Unit Sizing (°F)	-14	-22

Btu/hr/case † ‡	FF	IC
Parallel	8,900	9,200
Conventional	9,100	9,400

† Optional Energy Efficient Fan motors reduce refrigerant load by 654 Btu/hr/case.

‡ Includes EcoShine LED lighting.

DEFROST DATA

	FF	IC
Frequency (hr)	24	24
Defrost Water (lb/day)	8.6	8.6

(± 15% based on case configuration and product loading).

ELECTRIC	FF	IC
Temp Term (°F)	48	48
Failsafe (minutes)	45	45

GAS	FF	IC
Duration (minutes)	20	20

OFFTIME Not Recommended

Standard Defrost Thermostat
Close on rise: close 48°F — open 33°F

CONVENTIONAL CONTROLS

Low Pressure Backup Control	FF	IC
C/CO (Temp °F)*	-18/-34	-26/-45

Indoor Unit Only, Pressure Defrost Termination (Temp °F)*

Not Recommended

*Use a Temperature Pressure Chart to determine PSIG conversions.

Estimated Charge (lb/case)**

RLNIE	5.4
-------	-----

**This is an average for all refrigerant types. Actual refrigerant charge may vary by approximately half a pound.

Length added to Lineup by:

Each Standard End (in.)	2
Insulated Partition (in.)	1 1/2

NSF Certification

This merchandiser model is manufactured to meet ANSI/NSF (National Sanitation Foundation) Standard #7 requirements for construction, materials & cleanability.

LifeLine Premier RLNIE
 With INNOVATOR Doors
 Frozen Food & Ice Cream

Husmann recommends against frame heater cycling with Innovator doors to prevent door seals from freezing to the frames and tearing.

Electrical Data

Number of Fans – 12W

RLNIE
7
Amperes **Watts**

Merchandiser

Evaporator Fans

120V	60Hz	Standard	4.55	350
120V	50Hz	Standard	5.25	399
220V	60Hz	Export	2.31	350
220V	50Hz	Export	2.66	399
120V	60Hz	Energy Efficient	2.10	126
220V	60Hz	Energy Efficient	1.05	126

Door Anti-sweat Heaters (on fan circuit)

120V	50/60Hz	Standard	6.17	740
220V	50/60Hz	Export	3.36	744

Frame Anti-sweat Heaters (on fan circuit)

120V	50/60Hz	Standard	3.14	376
220V	50/60Hz	Export	1.71	376

Frame Anti-sweat Heaters (on fan circuit)

120V	50/60Hz	Standard	1.67	200
220V	50/60Hz	Export	0.87	200

Minimum Circuit Ampacity

120V	60Hz	Standard	15.73
120V	50Hz	Standard	16.43
220V	60Hz	Export	8.45
220V	50Hz	Export	8.80
120V	60Hz	Energy Efficient	13.28
220V	60Hz	Energy Efficient	7.19

Maximum Over Current Protection 120V

20

Maximum Over Current Protection 220V

15

Defrost

Drain Heaters (120V 60Hz)	1.89	225
Export (230V 50Hz)	1.02	252

Electric Defrost (208V 3 Phase) per phase value

11.70 2426

Standard LED Lighting

Husmann EcoShine [120V]	1.17	140
Husmann EcoShine [220V (Export)]	0.64	147

* *Innovator or Innovator II*

LifeLine Premier RLNIE
 With INNOVATOR Doors
 Frozen Food & Ice Cream

Product Data

<i>Recommended Usable Cube</i> ¹ (Cu Ft/Case)	148.52 ft ³ /Case (4.21 m ³ /Case)
<i>AHRI Total Display Area</i> ² (Sq Ft/Case)	131.90 ft ² /Case (12.25 m ² /Case)
<i>Shelf Area</i> ³ (Sq Ft/Case)	185.65 ft ² /Case (17.25 m ² /Case)

- ¹ AHRI Refrigerated Volume less shelving and other unusable space: Refrigerated Volume/Unit of Length, ft³/ft [m³/m]
² Computed using AHRI 1200 standard methodology: Total Display Area, ft² [m²]/Unit of Length, ft [m]
³ Shelf surface area is composed of bottom deck plus standard shelf complement, as shown in the Hussmann *Product Reference Guide*. The standard shelf complement for this model is (5) rows of 22-inch shelves.

ESTIMATED SHIPPING WEIGHT ⁵	
Case	<i>RLNIE</i>
lb (kg)	1980 (900)
⁵ Actual weights will vary according to optional kits included.	

Wiring Diagram is per side — two circuits required per case.

Fan and Heater Circuits - Electric Defrost (standard) RLNIE Front and Rear Compartment

CIRCLED NUMBERS = PARTS LIST ITEM NUMBERS
 R = Red P = Purple 2P = Purple (2 Bands) DB = Dark Blue BL = Black
 LB = Light Blue BR = Brown Y = Yellow OR = Orange W = White
THESE ARE MARKER COLORS (WIRE MAY VARY.)

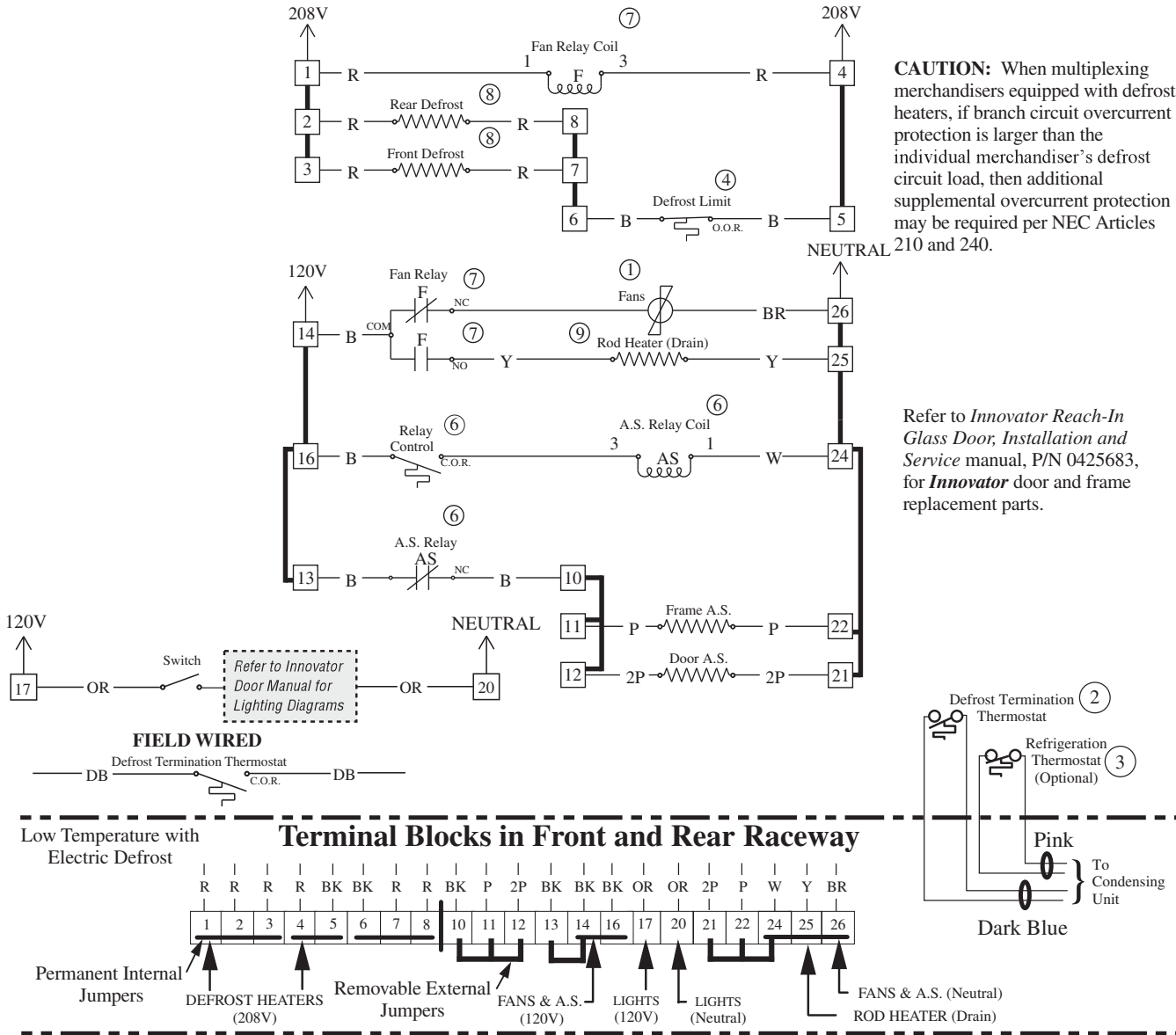

Front and Rear Compartments Connect to Main Terminal Block at Rear (see Page 10).

Wiring Diagram is per side — two circuits required per case.

Fan and Heater Circuits - Electric Defrost (standard)

RLNIE End Compartment

CIRCLED NUMBERS = PARTS LIST ITEM NUMBERS
 R = Red P = Purple 2P = Purple (2 Bands) DB = Dark Blue BL = Black
 LB = Light Blue BR = Brown Y = Yellow OR = Orange W = White
THESE ARE MARKER COLORS (WIRE MAY VARY.)

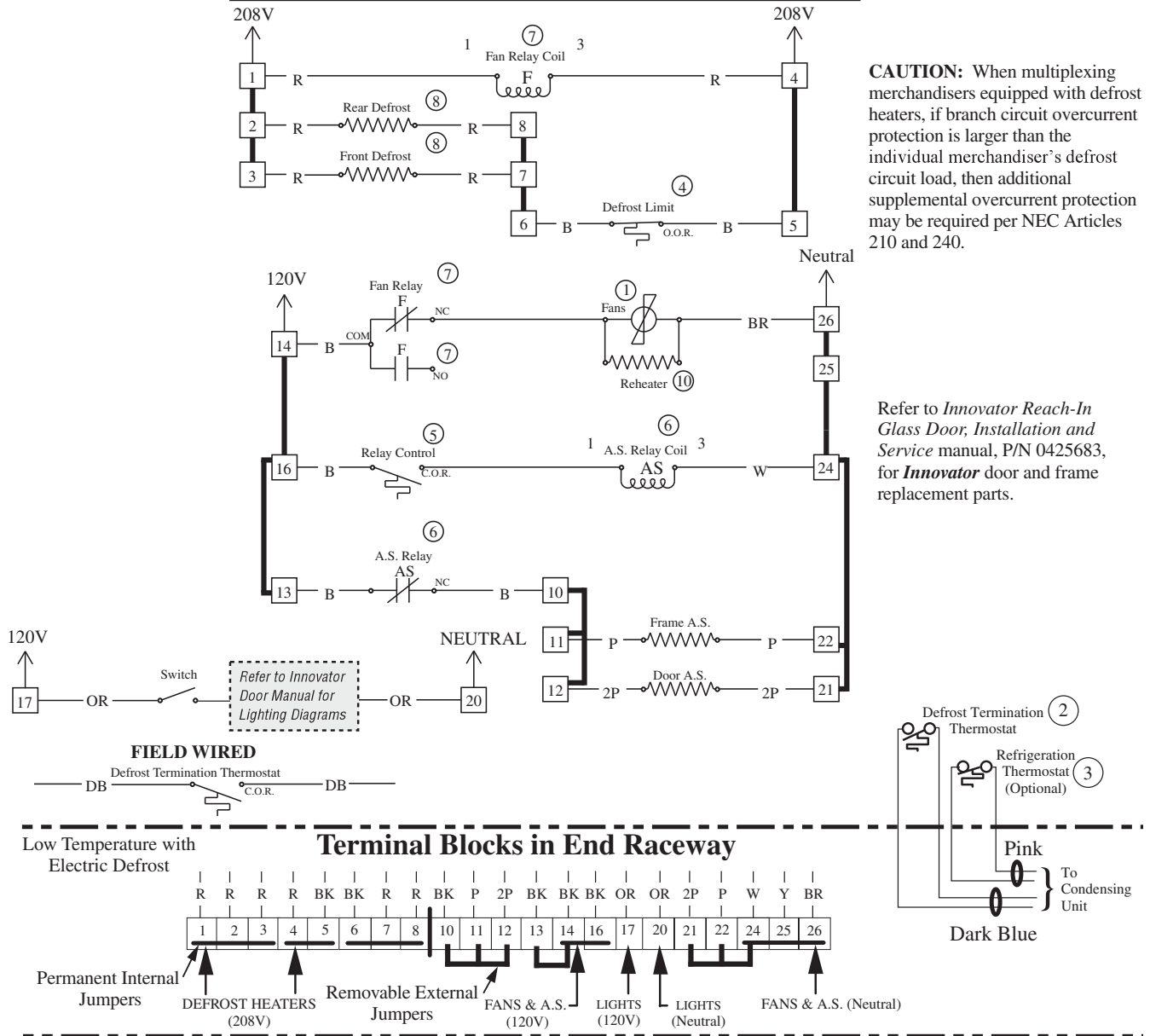

End Compartment Connects to Main Terminal Block at Rear (see Page 10).

RLNIE Wiring Diagram for Electric Defrost

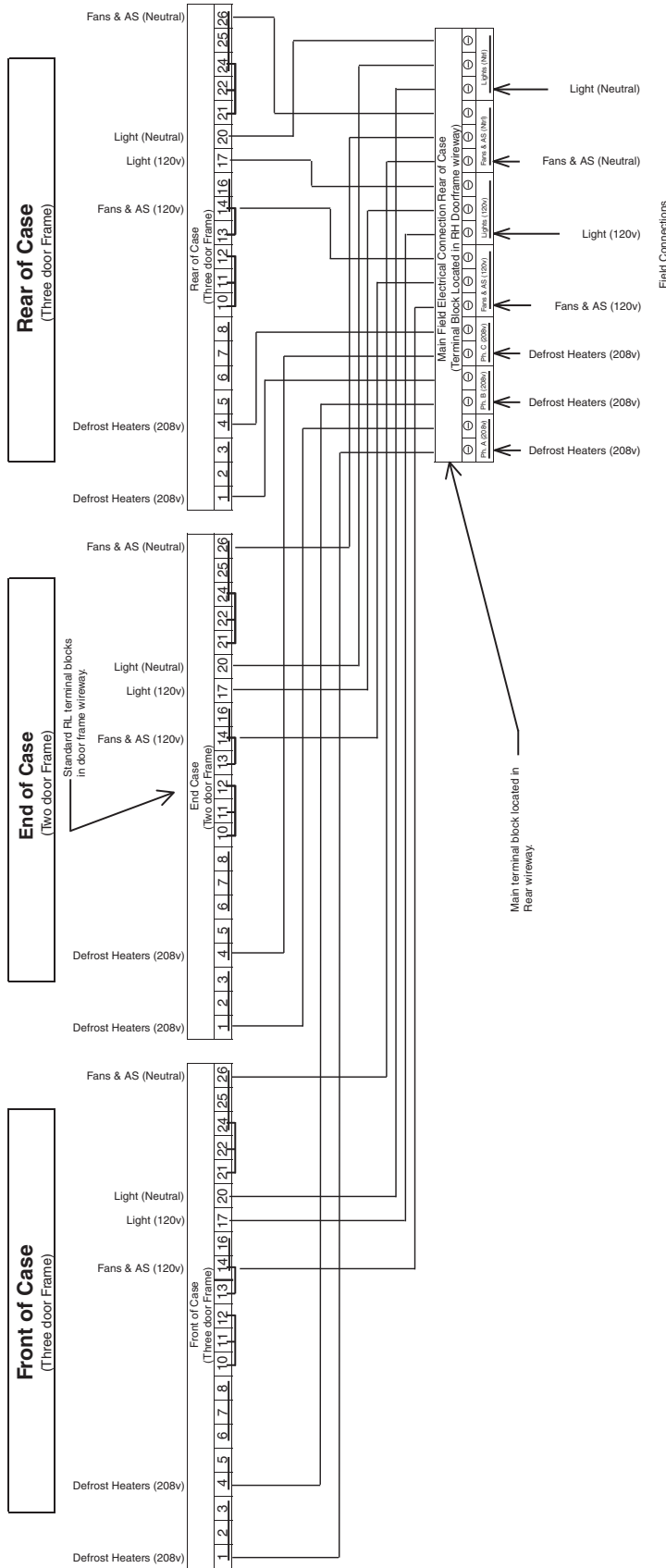

Electric Defrost Sequence - Low Temperature

1. Power from the defrost contactor energizes Defrost Heaters and 208V Evaporator Fan Relay Coil (7). Relay Contacts open the fan circuit and energizes the Drain Pan Heater.
2. If the Defrost Heater raises internal air temperature above 90°F, the Defrost Limit Thermostat (4) will open.
3. Temperature rise of the evaporator closes the Relay Control Thermostat (5) at about 35°F, energizing 120V A.S. Relay Coil (6). This relay's contacts open the Frame and Door Heater Circuits.
4. When Defrost Termination Thermostat ends defrost period, the defrost contactor opens the Defrost Heater and Evaporator Fan Relay Coil Circuits. The Drain Pan Heater goes off and fans are on.
5. Temperature fall of the evaporator opens the Relay Control Thermostat (5) at about 20°F, de-energizing 120V A.S. Relay Coil (6). A.S. Relay Contacts close the Frame and Door Heater Circuits.

Wiring Diagram is per side — two circuits required per case.

Fan and Heater Circuits - Gas Defrost (optional) RLNIE Front and Rear Compartment

CIRCLED NUMBERS = PARTS LIST ITEM NUMBERS
 R = Red P = Purple 2P = Purple (2 Bands) DB = Dark Blue BL = Black
 LB = Light Blue BR = Brown Y = Yellow OR = Orange W = White
THESE ARE MARKER COLORS (WIRE MAY VARY.)

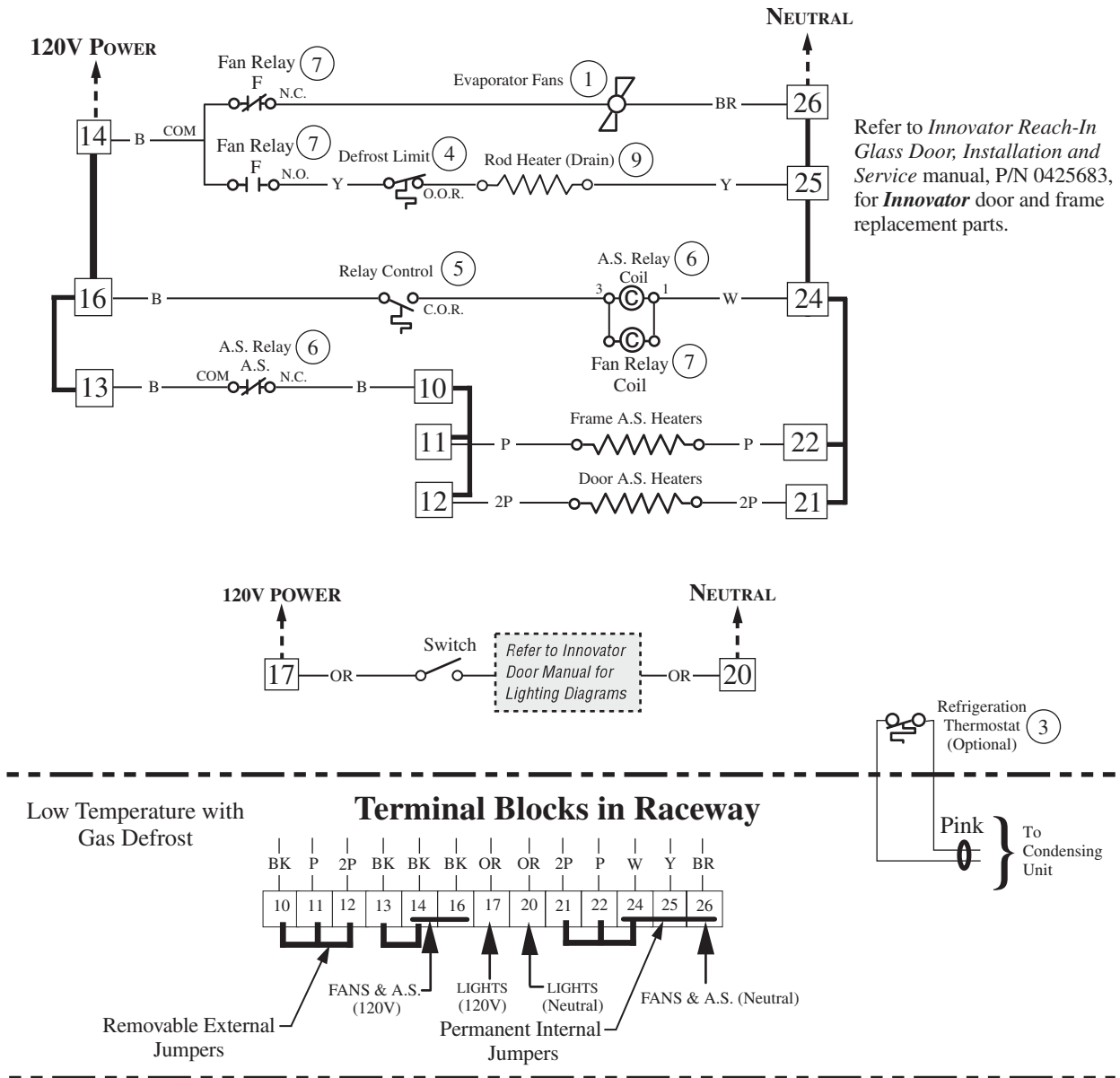

Front and Rear Compartments Connect to Main Terminal Block at Rear (see Page 13).

Wiring Diagram is per side — two circuits required per case.

Fan and Heater Circuits - Gas Defrost (optional) RLNIE End Compartment

CIRCLED NUMBERS = PARTS LIST ITEM NUMBERS
 R = Red P = Purple 2P = Purple (2 Bands) DB = Dark Blue BL = Black
 LB = Light Blue BR = Brown Y = Yellow OR = Orange W = White
THESE ARE MARKER COLORS (WIRE MAY VARY.)

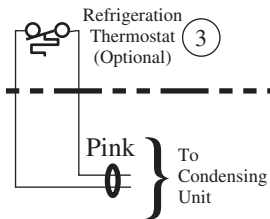
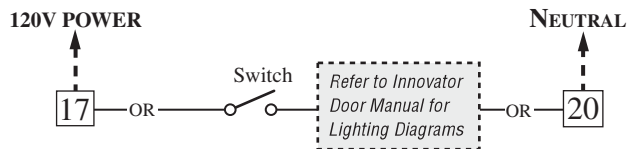
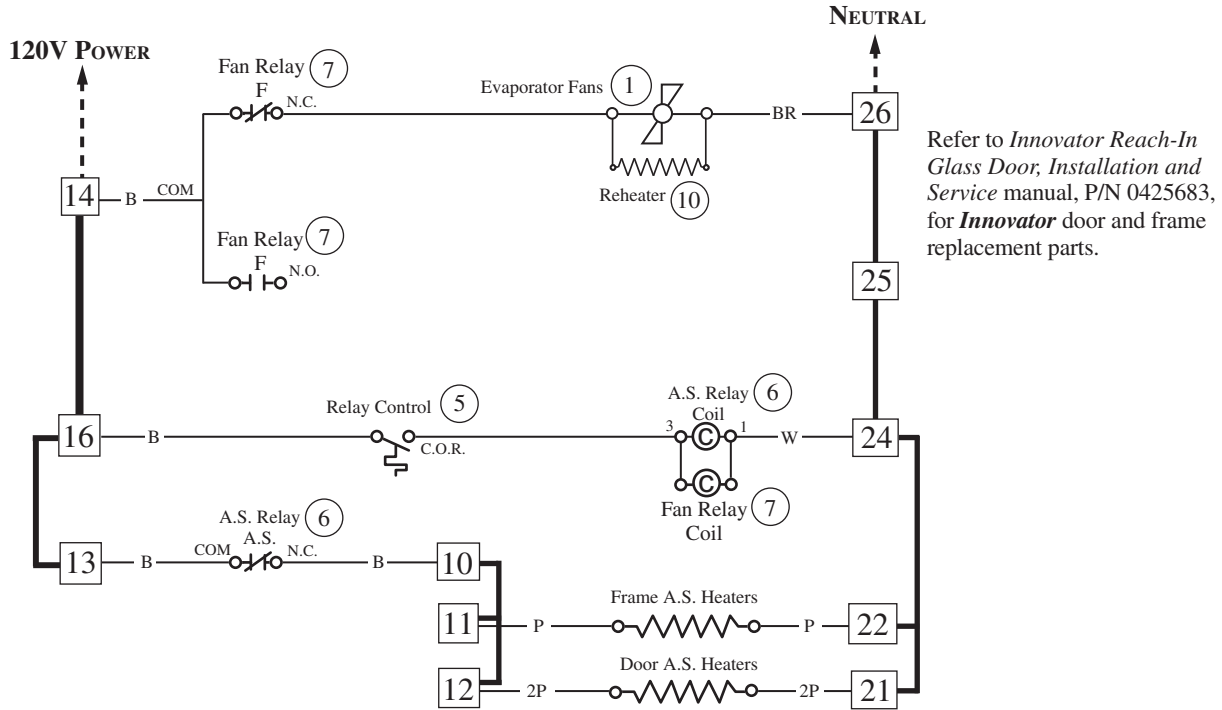

Low Temperature with Gas Defrost

Terminal Blocks in Raceway

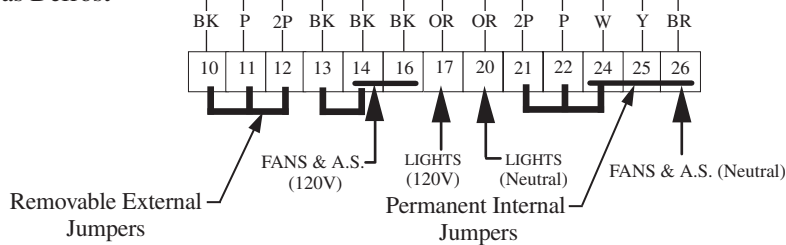

End Compartment Connects to Main Terminal Block at Rear (see Page 13).

RLNIE Wiring Diagram for Gas Defrost

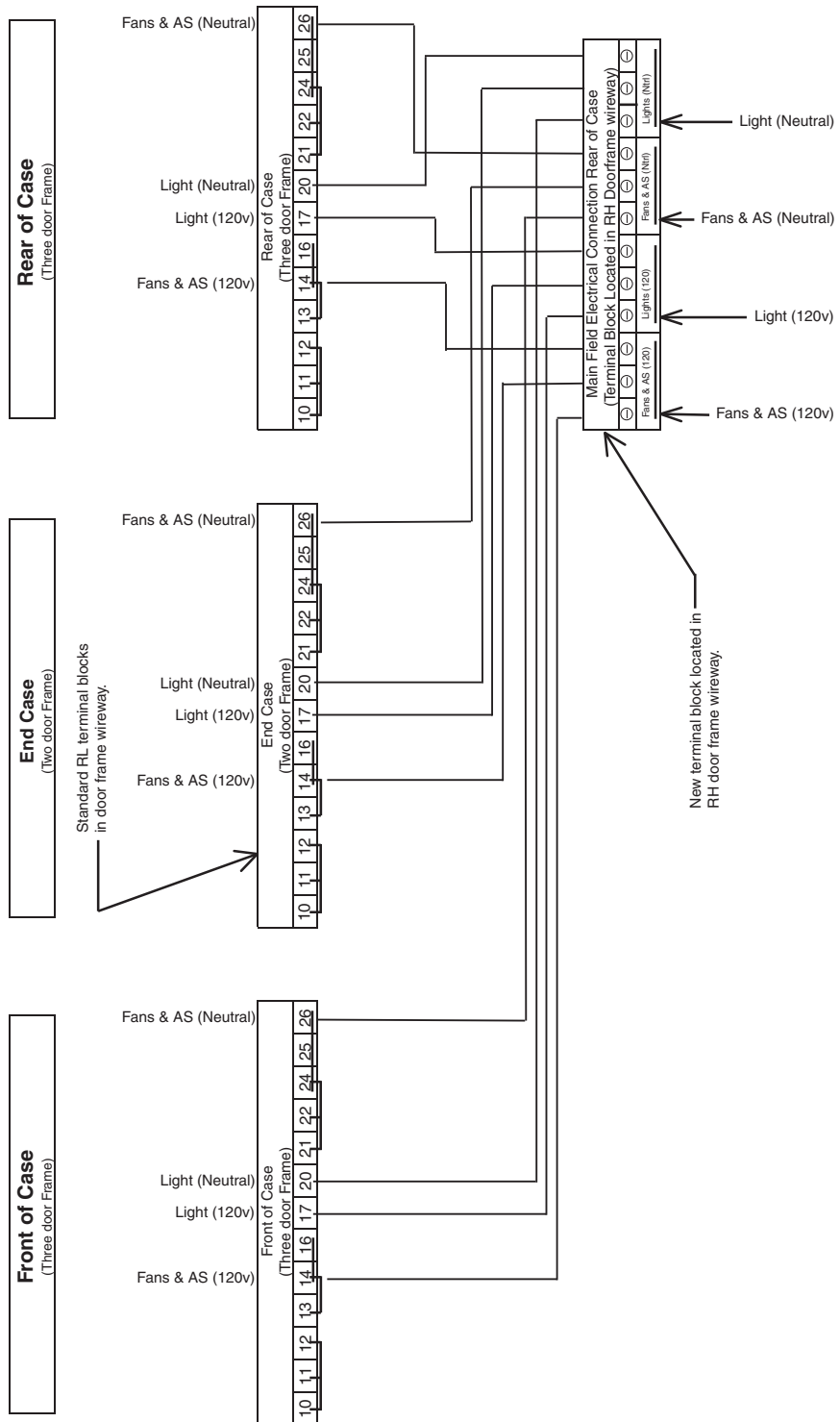

Gas Defrost Sequence - Low Temperature

1. Defrost vapor enters evaporator causing a rise in temperature. At about 35°F the Control Relay Thermostat (5) closes the Fan Relay Coil (7) and Control Relay Coil (6) circuit. The Coil opens the Fan, Door Heater, and Frame Heater circuits, while energizing the Drain Pan Heater (9).
2. If the Drain Pan Heater (9) raises internal air temperature above 90°F, the Heater Limit Thermostat (4) will open.
3. When the defrost timer ends a defrost period, the evaporator temperature will start to fall. At about 20°F, the Control Relay Thermostat will open, de-energizing the Control Relay Coil and Fan Relay Coil (7). Control and Fan Relay's will open the Drain Pan Heater circuits, and will close the Fan, Door Heater, and Frame Heater circuits.

LifeLine Premier RLNIE

With INNOVATOR Doors
Frozen Food & Ice Cream

Optional Lighting 12V Power Supply EcoShine LED Lighting Circuits

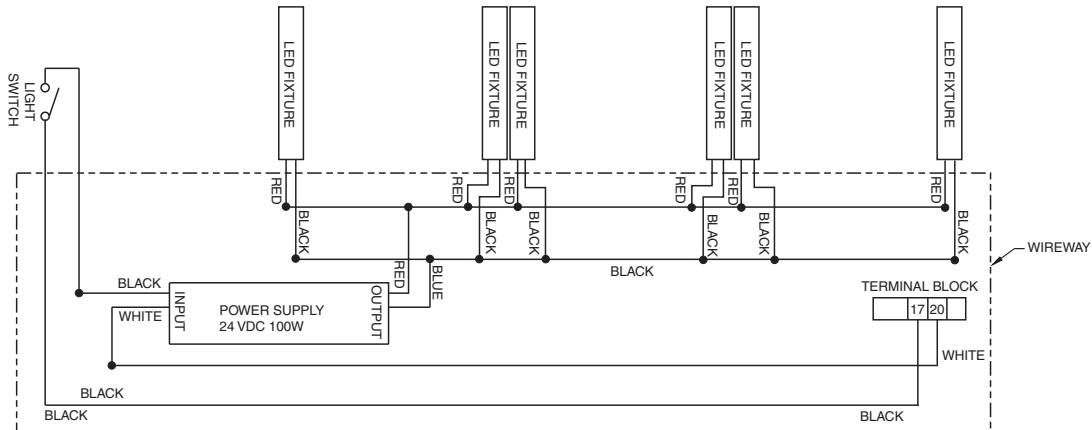

3 DOOR RH SIDE COMPARTMENT LED LIGHT WIRING DIAGRAM

Wiring Diagrams shown are for the RLNIE Island merchandisers with 60 in. EcoShine or EcoShine Energy Plus LEDs.

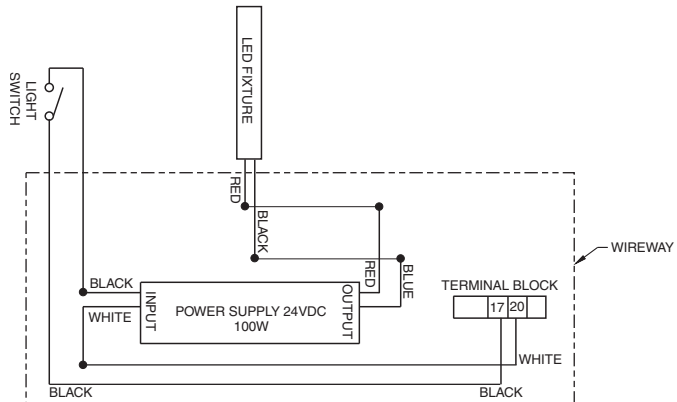

2 DOOR END COMPARTMENT LED LIGHT WIRING DIAGRAM

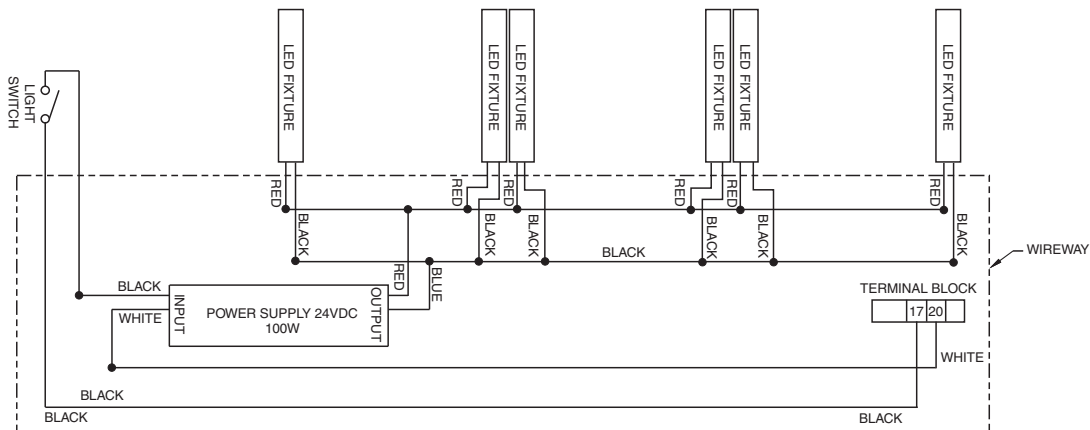

3 DOOR LH SIDE COMPARTMENT LED LIGHT WIRING DIAGRAM

LifeLine Premier RLNIE

With INNOVATOR Doors
Frozen Food & Ice Cream

Optional Lighting Circuits

CIRCLED NUMBERS = PARTS LIST ITEM NUMBERS

R = Red P = Purple 2P = Purple (2 Bands)

DB = Dark Blue B = Black

BR = Brown Y = Yellow OR = Orange W = White

THESE ARE MARKER COLORS (WIRE MAY VARY.)

External Facade LED Wiring

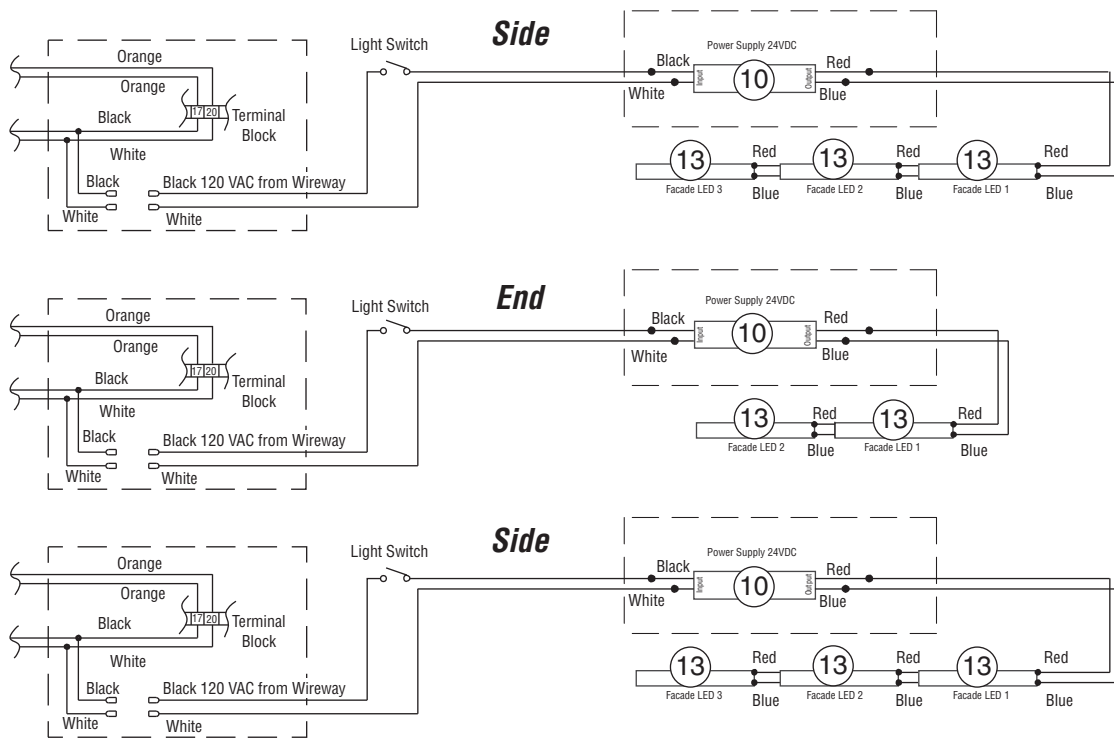

Lights Connected in Series — Maximum of Five (5) Lights per Power Supply



WARNING

All components must have mechanical ground, and the merchandiser must be grounded.

● = 120V POWER ○ = 120V NEUTRAL ⊥ = FIELD GROUND ≡ = CASE GROUND