

PARTS LIST

Item	Quantity		Description
	D5X-LE	D5X-E	
1.	2	2	Nut Retainer $5/16$ -18 (left end only)
2.	1	1	Gasket Tape $1/2 \times 1\frac{5}{8} \times 180$
3.	1	1	Gasket Tape $1 \times 1/2 \times 180$
4.	1	1	Silicone Sealer
5.	1	1	Bottom End Assembly
6.	2	2	Cap Screw $5/16$ -18 x $2\frac{1}{2}$
7.	4	4	Flat Washer $5/16$
8.	1	1	Top End Assembly
9.	2	2	Cap Screw $5/16$ -18 x $1\frac{3}{4}$
10.	1	1	Multiglass Assembly
11.	1	1	Multiglass Extrusion
12.	6	6	Screw – SM Hex Head – TEK2 – #8-18 x $1/2$
13.	1	1	Fascia End Plate
14.	1	1	Bumper End Plate (PART OF END BUMPER KIT)
15.	1	1	Fascia Panel
16.	2	2	Bracket — End Splashguard
17.	1	1	End Splashguard Cover
18.	1	1	Splashguard — Standard 5.75 End
19.	4	4	Screw – Truss Head – Phillips – #8-18 x $1/2$ – Black
20.	1	1	Corner Bumper (PART OF END BUMPER KIT)
21.	1	1	End Bumper (PART OF END BUMPER KIT)

All equipment should be thoroughly examined for shipping damage before and during unloading.

This equipment has been carefully inspected at our factory. Any claim for loss or damage must be made to the carrier. The carrier will provide any necessary inspection reports and/or claim forms.

Every effort is made to ship all parts for the kit. The Hussmann Service Center can be reached by calling

- from U.S. & Canada 1-800-922-1919 •
- from Mexico 1-800-522-1900 •

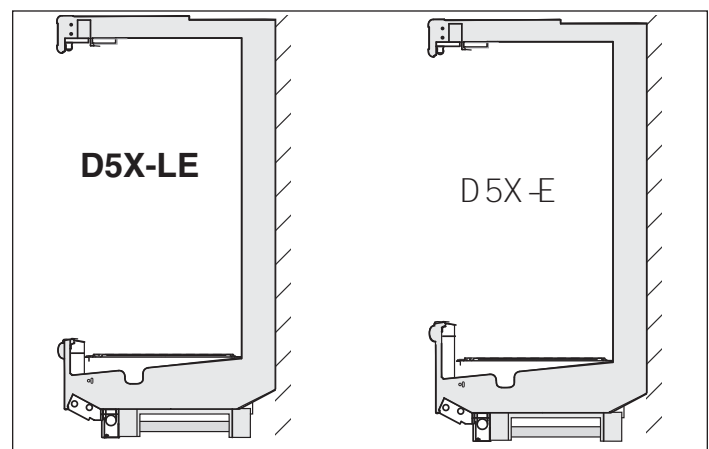

P/N 0503025_A

January 2008

INSTALLING END ASSEMBLIES

End assemblies are normally factory installed. The following information is provided for retrofit or field installation.

1 Uncrate

Place glass crate on flat surface with braces down as shown in Figure 1, Detail A. Remove screws from top.

Lift off top as shown in Detail B of Figure 1.

Remove cardboard packaging as shown in Detail C of Figure 1 and inspect Glass and Extrusion for damage.

Carefully unpack crate with end assemblies. Check for damage.

Locate and identify the parts listed on Page 1.

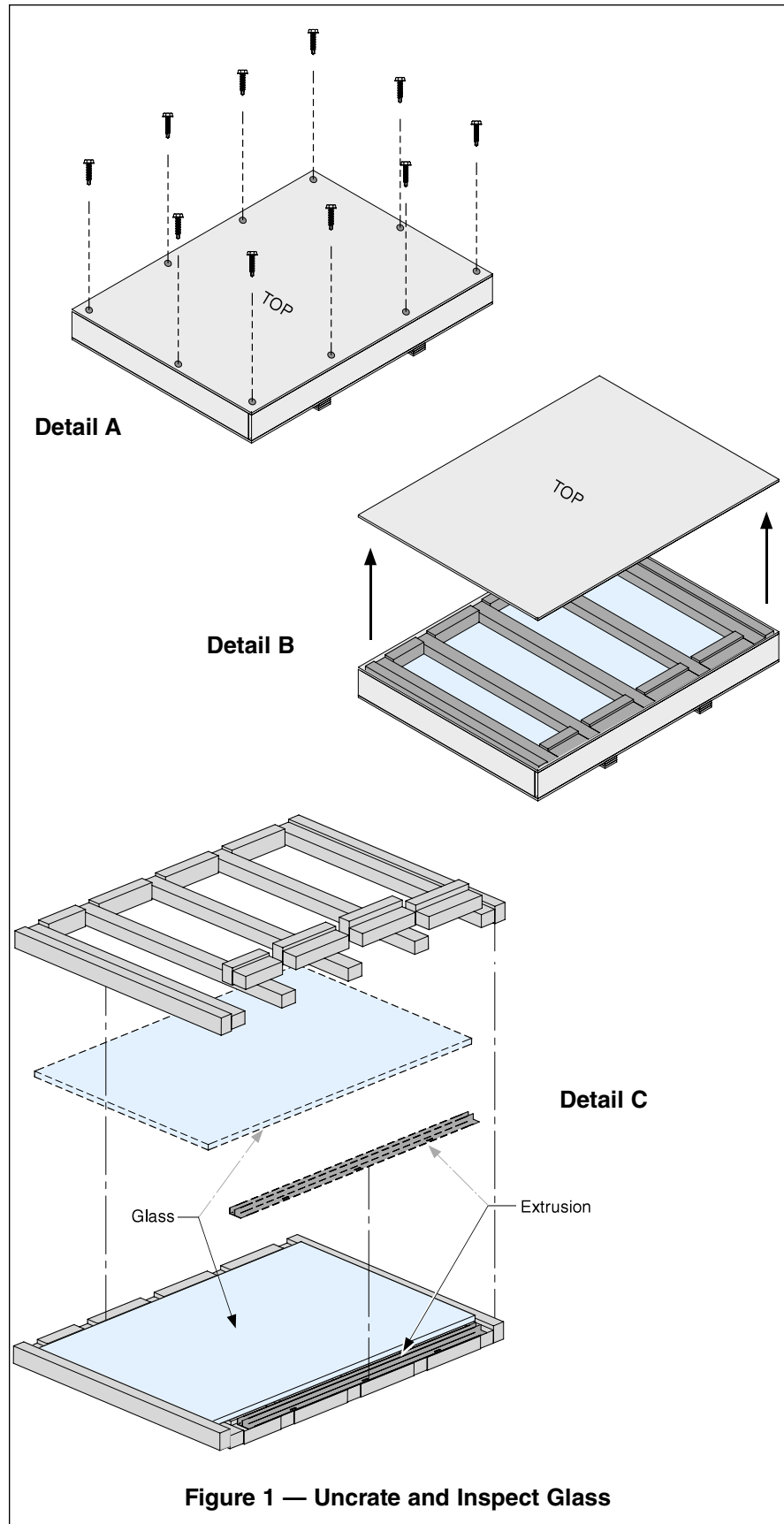

Figure 1 — Uncrate and Inspect Glass

2 Preparation

Left End Only

Install **Nut Retainers** – 1 in canopy positions indicated in Figure 2.

Remove any other nut retainers and alignment pins from End Frame.

Right End Only.

Remove any factory-installed alignment pins.

Verify Nut Retainers are in canopy positions indicated in Figure 2. Remove all others.

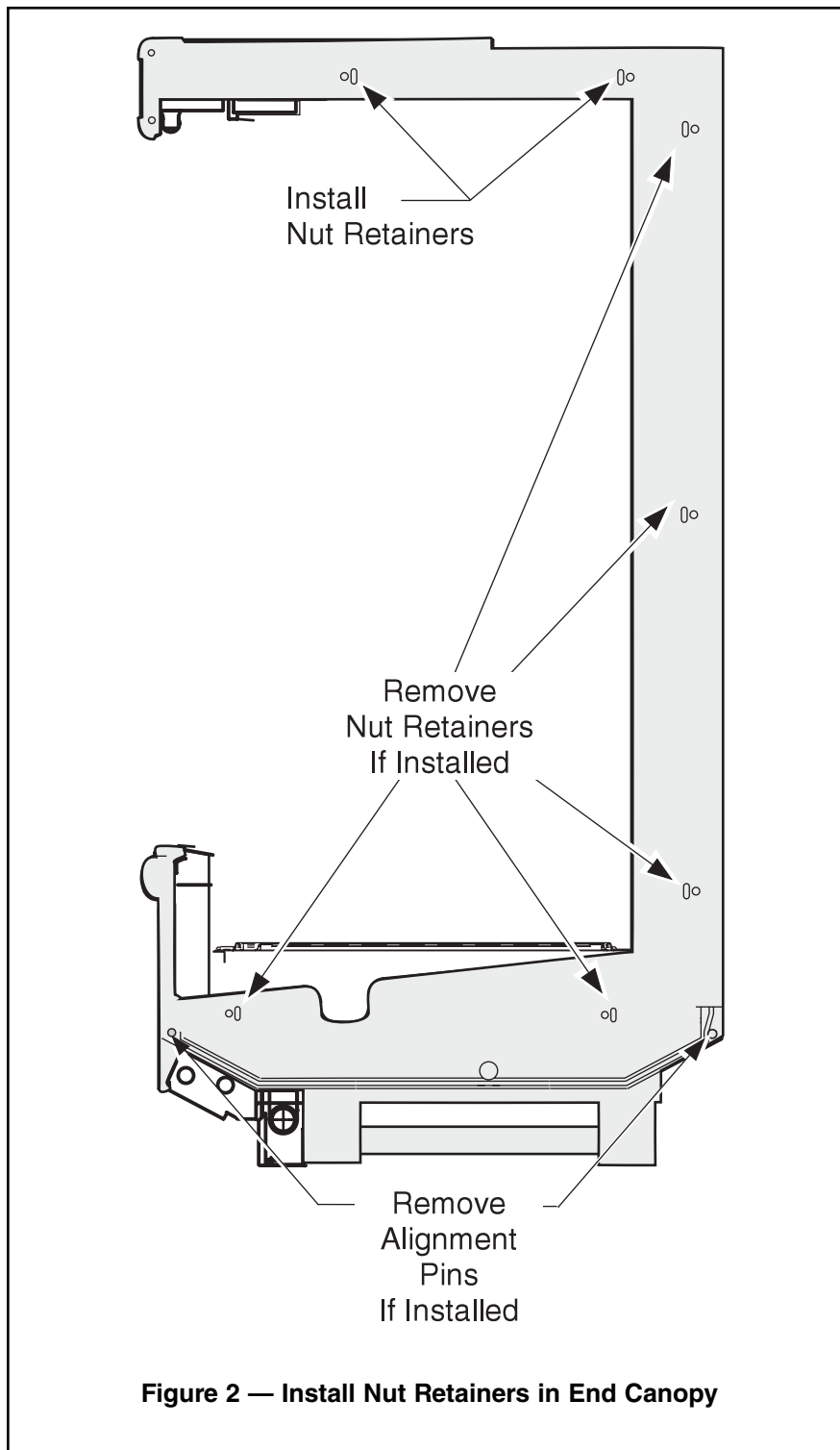

Figure 2 — Install Nut Retainers in End Canopy

3 Apply Gasket

Apply **Gasket – 2** and **Gasket – 3** as indicated in Figure 3.

The same gasket arrangement is used on either end.

Assure good adhesion of gaskets by wiping the end frame with rubbing alcohol to remove accumulated dust and oils.

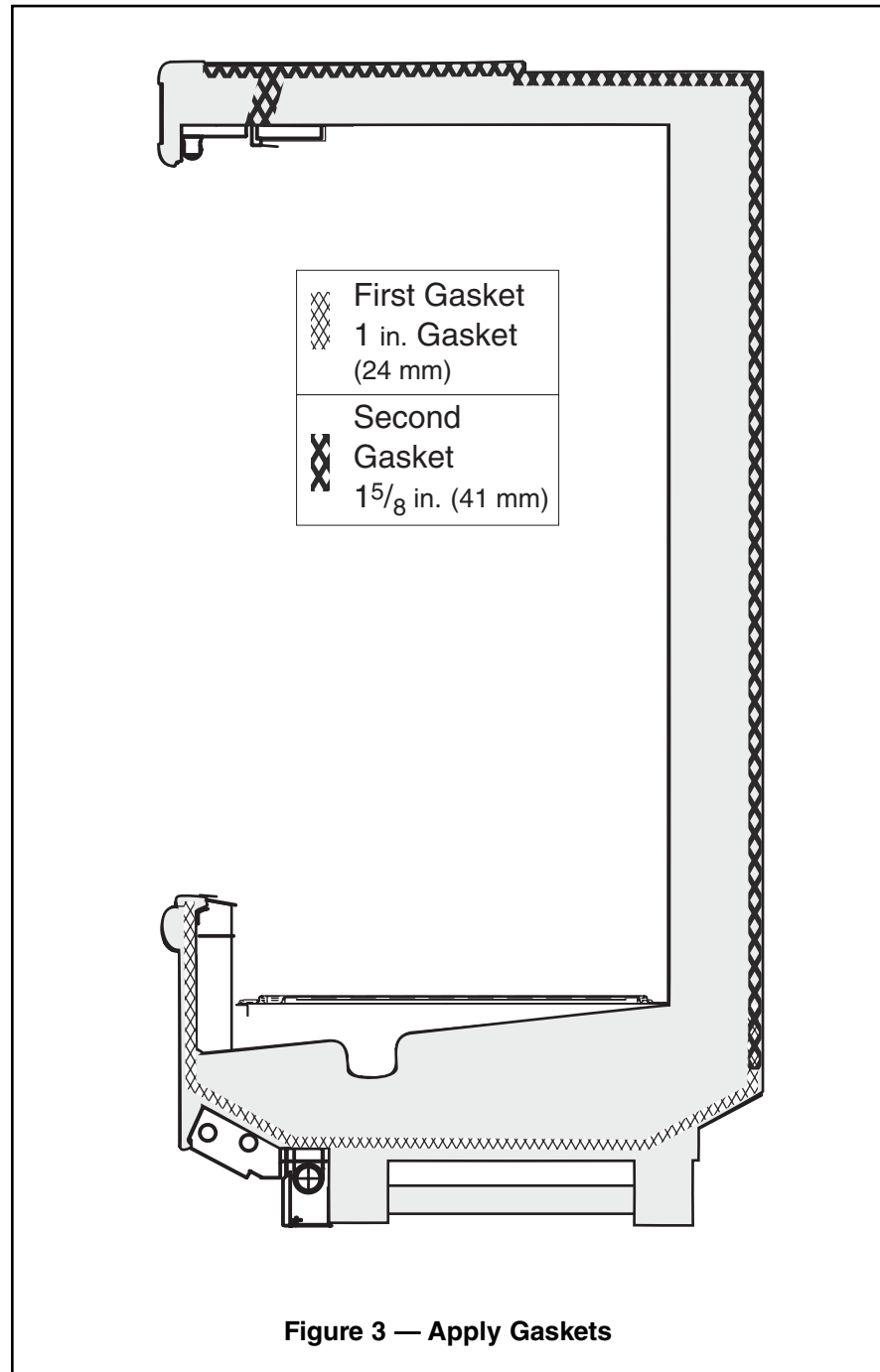



4 Align **Bottom End Assembly – 5** with end frame. Working from inside the case as shown in Figure 4, insert **Cap Screw – 6** through **Flat Washer – 7**, then through end frame and into end assembly.

5 Use **Silicone Sealer – 4** to seal end frame to end assembly as shown in Figure 5.

Apply **Silicone Sealer – 4** over both **Cap Screws – 6** as shown in Detail 5A

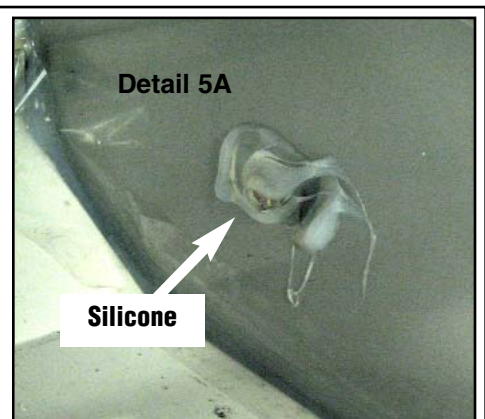
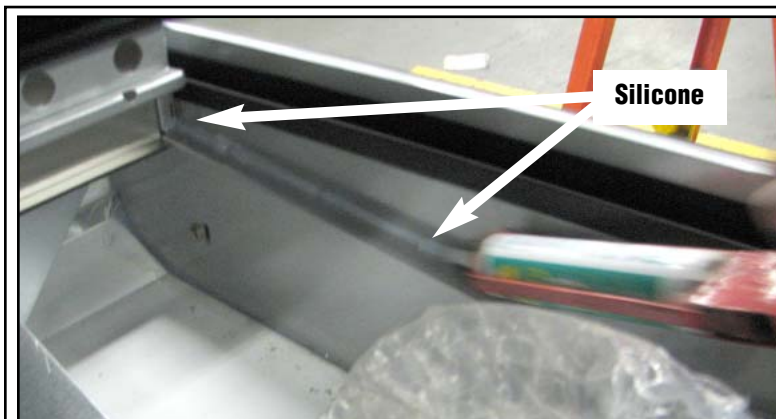

6 Align **Top End Assembly – 8** with end frame. Pins in the assembly fit into the canopy end frame as shown in Figure 6.

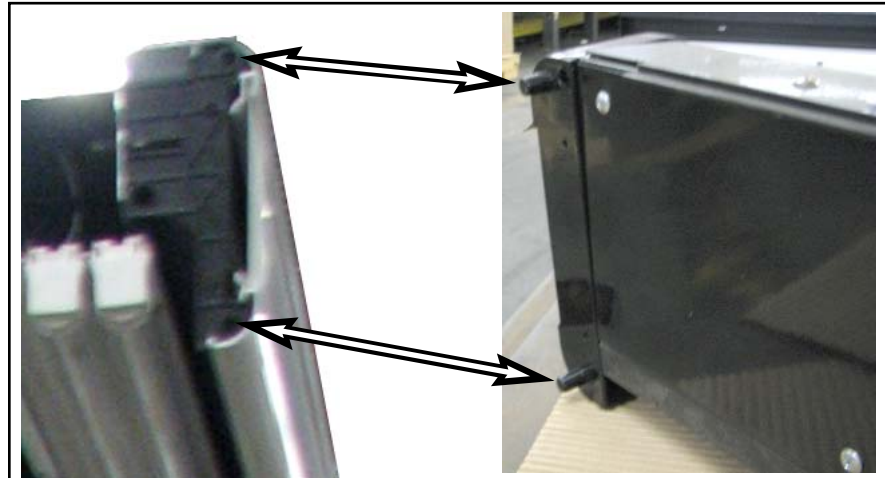

Figure 6 — Align Top End Assembly

7 Working from outside the case, attach **Top End Assembly – 7** to end frame with **Cap Screws – 9** as shown in Figure 7.

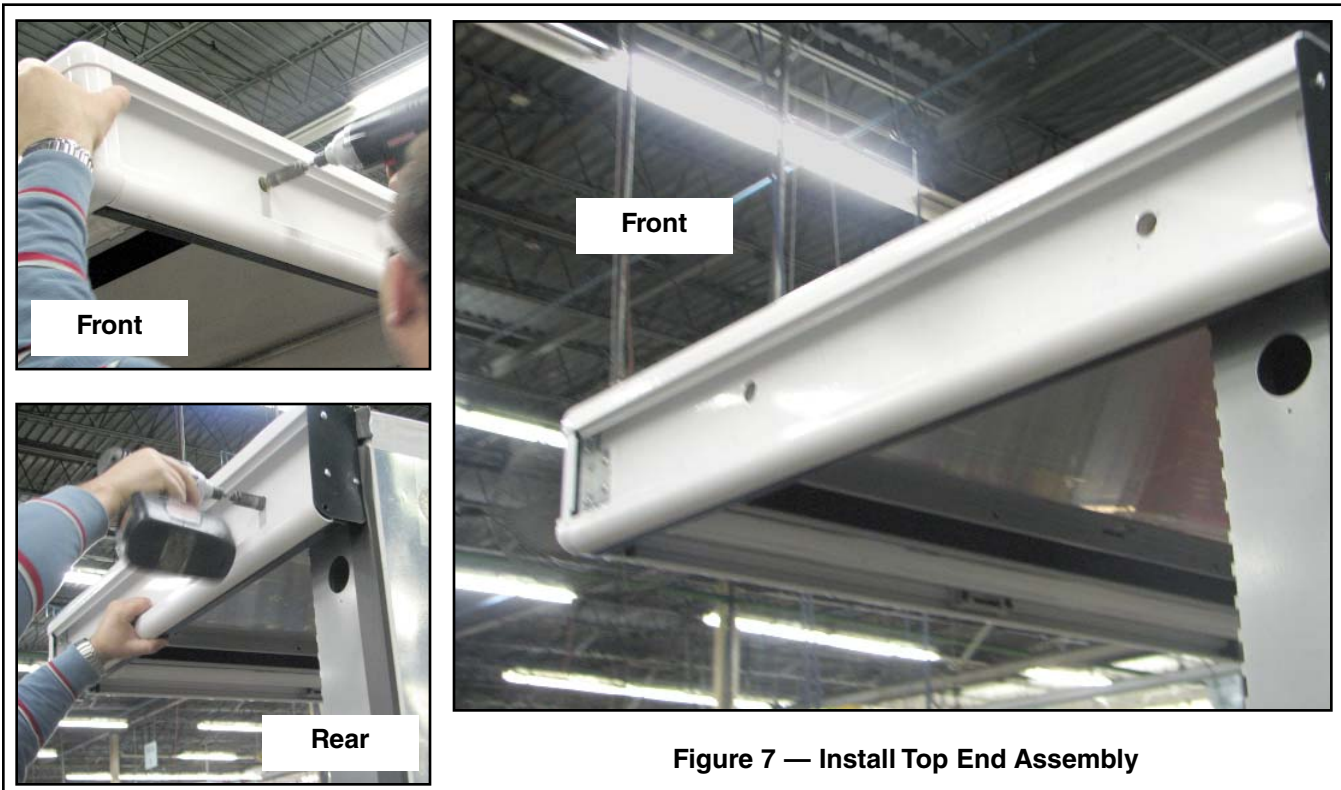

Figure 7 — Install Top End Assembly



8 From the back, insert the **Multiglass Assembly – 10** between bottom and top end assemblies. Refer to photos in Figure 8. Push the multiglass forward to butt against the front corner trim.

This may require two people!

Figure 8 — Install Multiglass Assembly

9 Attach the **Glass Extrusion – 11** at the back of the multiglass assembly using **Screws – 12**. Refer to photos in Figure 9.

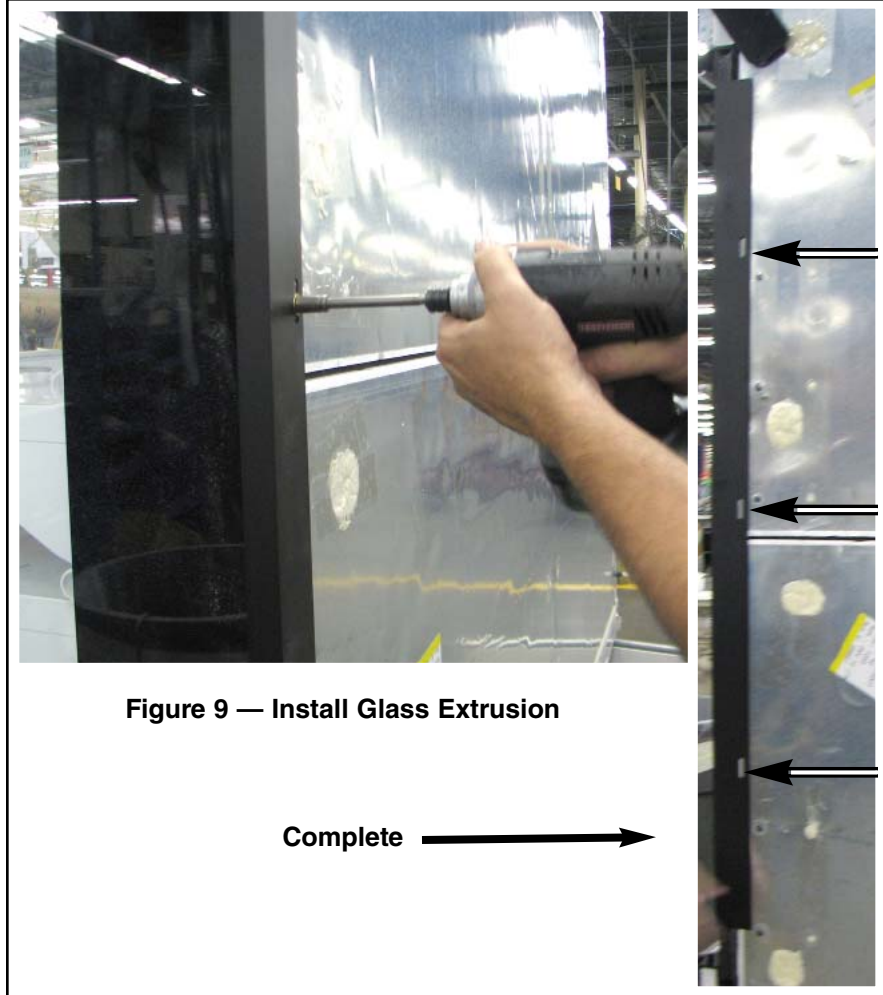

10 Attach the **Fascia End Plate – 13** at the back of the upper end assembly using **Screws – 12**. Refer to photo in Figure 10.

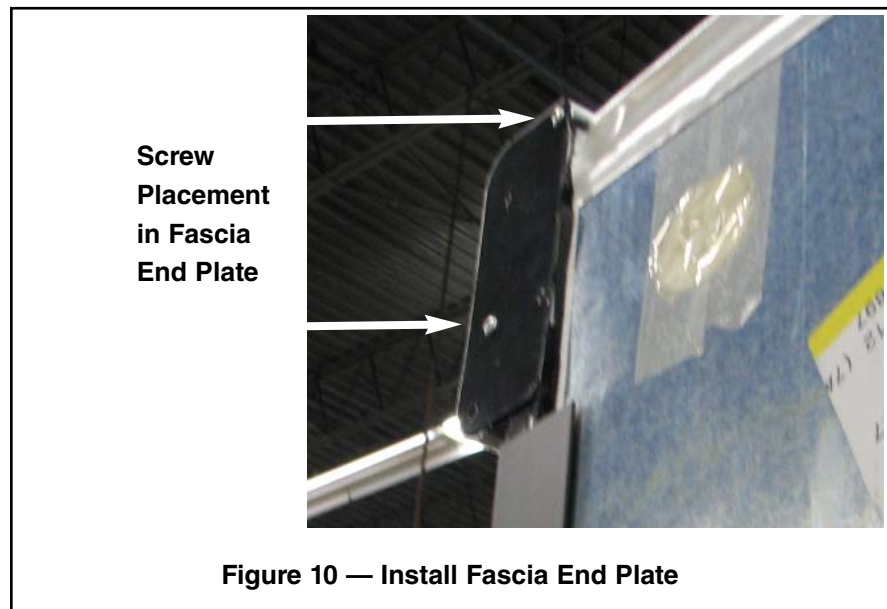

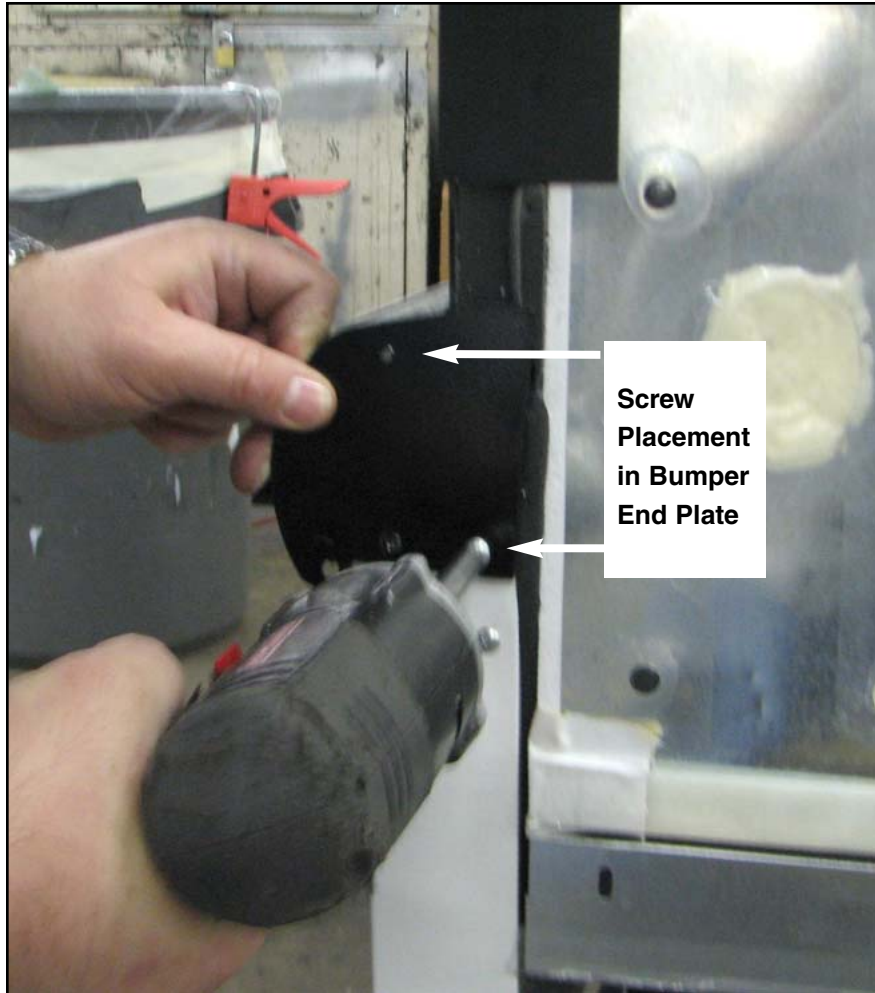

(PART OF END BUMPER KIT)

- 11** Attach the **Bumper End Plate – 14** at the back of the upper end assembly using **Screws – 12**. Refer to photo in Figure 11.

Figure 11 — Install Bumper End Plate

- 12** Insert the top edge of the **Fascia Panel – 15** into the top end assembly, slide upward until the bottom edge clears the lower track, then lower the panel. No fasteners are used. Refer to Figure 12.

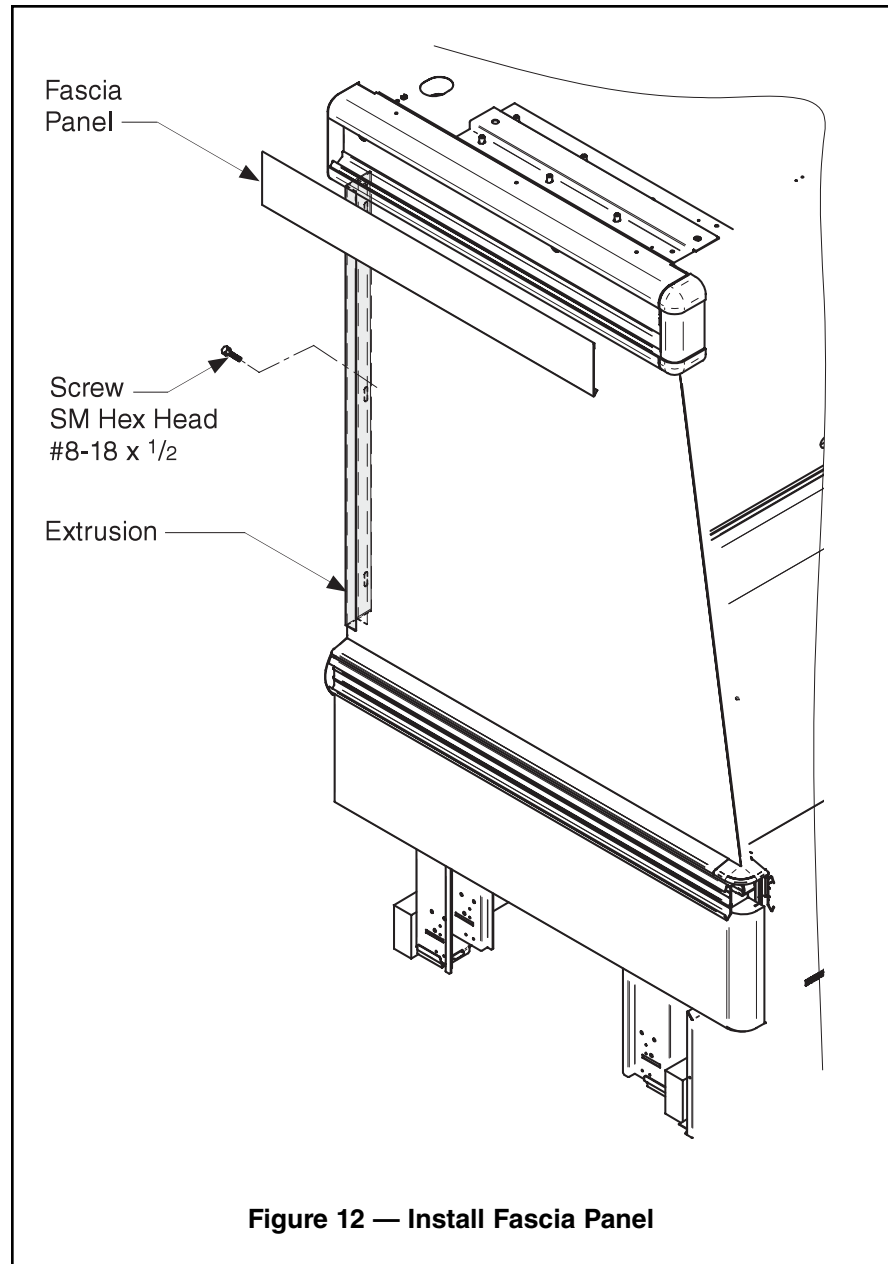
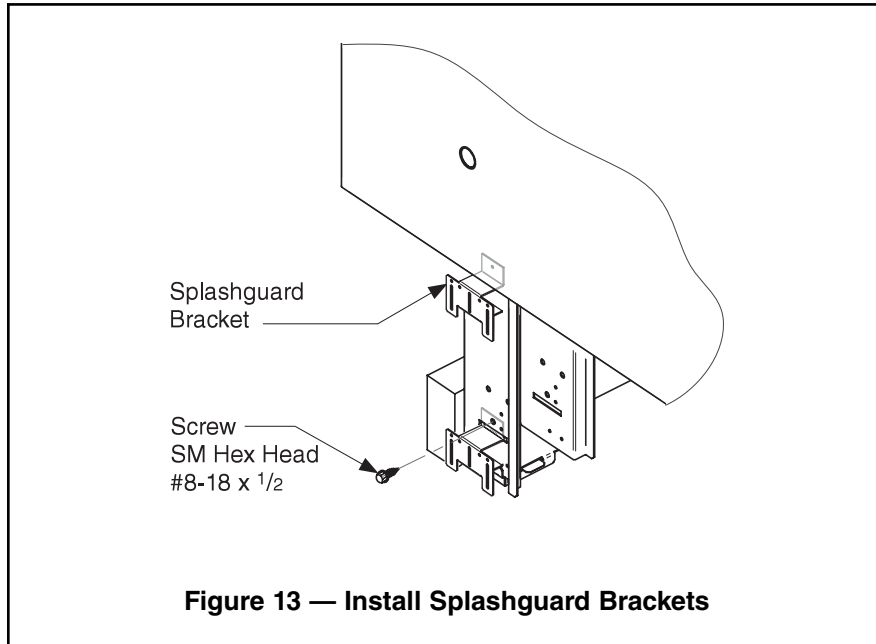
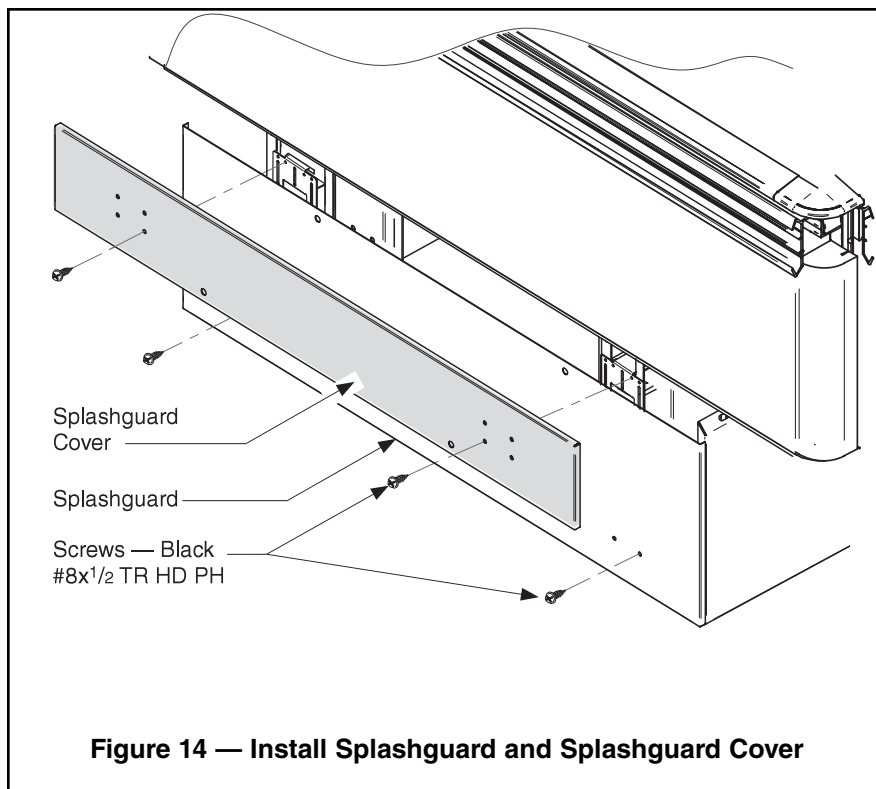

Figure 12 — Install Fascia Panel



13 Attach the **Splashguard Brackets – 16** to side of legs using **Screws – 12**. Refer to **Figure 13**.



14 Attach the **End Splashguard Cover – 17** and **End Splashguard – 18** to the splashguard brackets using **Screws – 19**. Refer to **Figure 14**.

15 Install the **Corner Bumper Cover – 20** and **End Bumper – 21** on the bottom end assembly. Refer to photos in Figure 15.

(PART OF END BUMPER KIT)



Figure 15 — Install End Bumpers