

We reserve the right to change or revise specifications and product design in connection with any feature of our products. Such changes do not entitle the buyer to corresponding changes, improvements, additions or replacements for equipment previously sold or shipped.

Item	Part #	Description	Wiring Item #	Item	Part #	Description	Wiring Item #
FAN ASSEMBLIES				THERMOSTATS			
4 Ft, 8 Ft & 12 Ft				B. Optional Adjustable Refrigeration Thermostat (2)			
A.	4W Standard Fan Assembly		(1)	LAMPS AND BALLASTS			
	0392457	Fan Motor, Evaporator (MO.4410101)		None			
	0464847	Fan Blade (FB.4780649)					
	4W Energy Efficient Fan Assembly		(1)				
	0477653	Fan Motor, Evaporator (MO.4410544)					
	0464847	Fan Blade (FB.4780649)					
6 Ft Only							
A.	4W Standard Fan Assembly		(1)				
	0392457	Fan Motor, Evaporator (MO.4410101)					
	0252116	Fan Blade (FB.4780611)					
	4W Energy Efficient Fan Assembly		(1)				
	0477653	Fan Motor, Evaporator (MO.4410544)					
	0252116	Fan Blade (FB.4780611)					

Note: Revision C adds Btu note (page 3). Other changes marked by bar, underline or circle.



Engineering Plan Views

PHYSICAL DATA

Merchandiser Drip Pipe (in.)	1 1/4
Merchandiser Liquid Line (in.)	3/8
Merchandiser Suction Line (in.)	5/8

Meat, Delicatessen and Produce



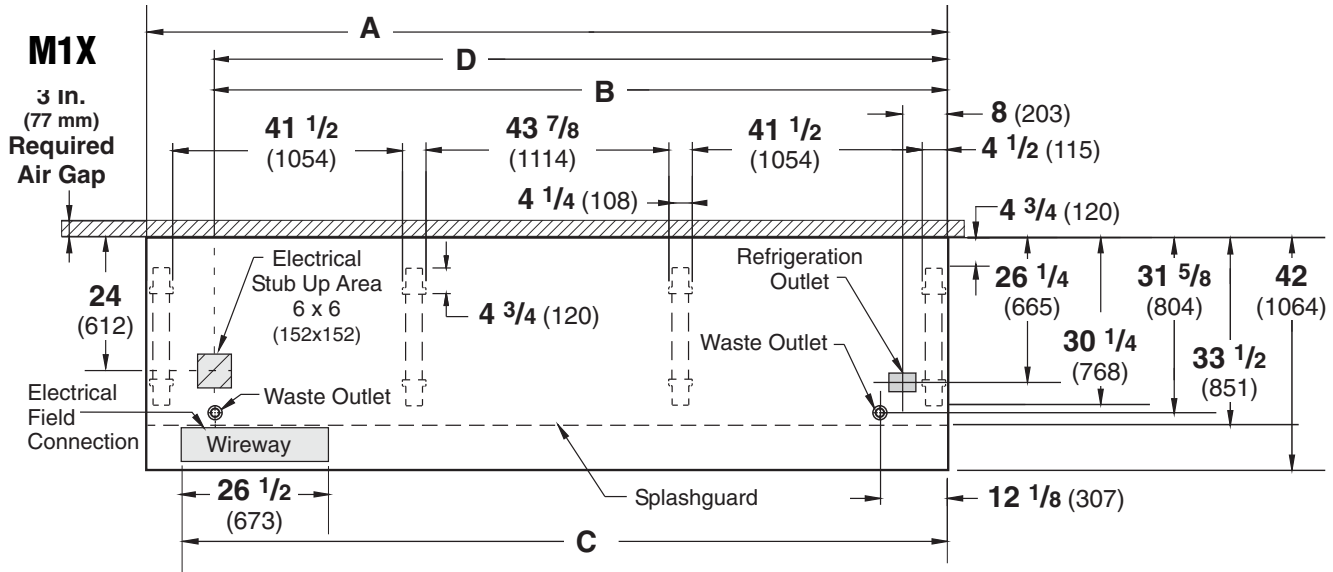

09-2005

Dimensions shown as in. and (mm).



NOTE: Case-to-Case Electrical Connections are made IN FRONT OF SPLASHGUARD.

FRONT

	4 ft	6 ft	8 ft	12 ft
General				
(A) Case Length (<i>without ends or partitions</i>)	48 3/8 (1229)	72 3/8 (1838)	96 3/8 (2448)	144 1/2 (3670)
<i>(Each end and insulated partition adds 1 1/2 in. (38 mm) to case line up.)</i>				
Maximum O/S dimension of case back to front <i>(includes bumper)</i>	42 (1064)	42 (1064)	42 (1064)	42 (1064)
Back of case to front of splashguard	33 1/2 (851)	33 1/2 (851)	33 1/2 (851)	33 1/2 (851)
Back of case to O/S edge of front leg	30 1/4 (768)	30 1/4 (768)	30 1/4 (768)	30 1/4 (768)
Distance between edges of external legs and center legs	NA	29 1/2 (750)	41 1/2 (1054)	41 1/2 (1054)
Distance between edges of center legs	NA	NA	NA	43 7/8 (1114)
Distance between front legs and splashguard	2 3/4 (70)	2 3/4 (70)	2 3/4 (70)	2 3/4 (70)
Electrical Service  (<i>Electrical Field Wiring connection point</i>)				
(B) RH End of case to center of stub up area	36 1/4 (921)	60 1/4 (1530)	84 1/4 (2140)	132 3/8 (3363)
Back of case to center of stub up area	24 (612)	24 (612)	24 (612)	24 (612)
Length of electrical wireway 	26 1/2 (673)	26 1/2 (673)	26 1/2 (673)	26 1/2 (673)
(C) RH End of case to LH end of wireway	42 1/8 (1070)	66 1/8 (1680)	90 1/8 (2289)	138 1/4 (3511)
Waste Outlets (<i>One each end</i>) 				
(D) RH End of case to the center of LH waste outlet	36 1/4 (921)	60 1/4 (1530)	84 1/4 (2140)	132 3/8 (3363)
RH End of case to the center of RH waste outlet	12 1/8 (307)	12 1/8 (307)	12 1/8 (307)	12 1/8 (307)
Back O/S of case to center of waste outlets	31 5/8 (804)	31 5/8 (804)	31 5/8 (804)	31 5/8 (804)
Schedule 40 PVC drip pipe	1 1/4 (32)	1 1/4 (32)	1 1/4 (32)	1 1/4 (32)
Refrigeration Outlet 				
Back of case to center of refrigeration outlet	26 1/4 (665)	26 1/4 (665)	26 1/4 (665)	26 1/4 (665)
RH end of case to center of refrigeration outlet	8 (203)	8 (203)	8 (203)	8 (203)

Single Deck, 1 Display Level, Glass Front

Dimensions shown as inches and (mm).

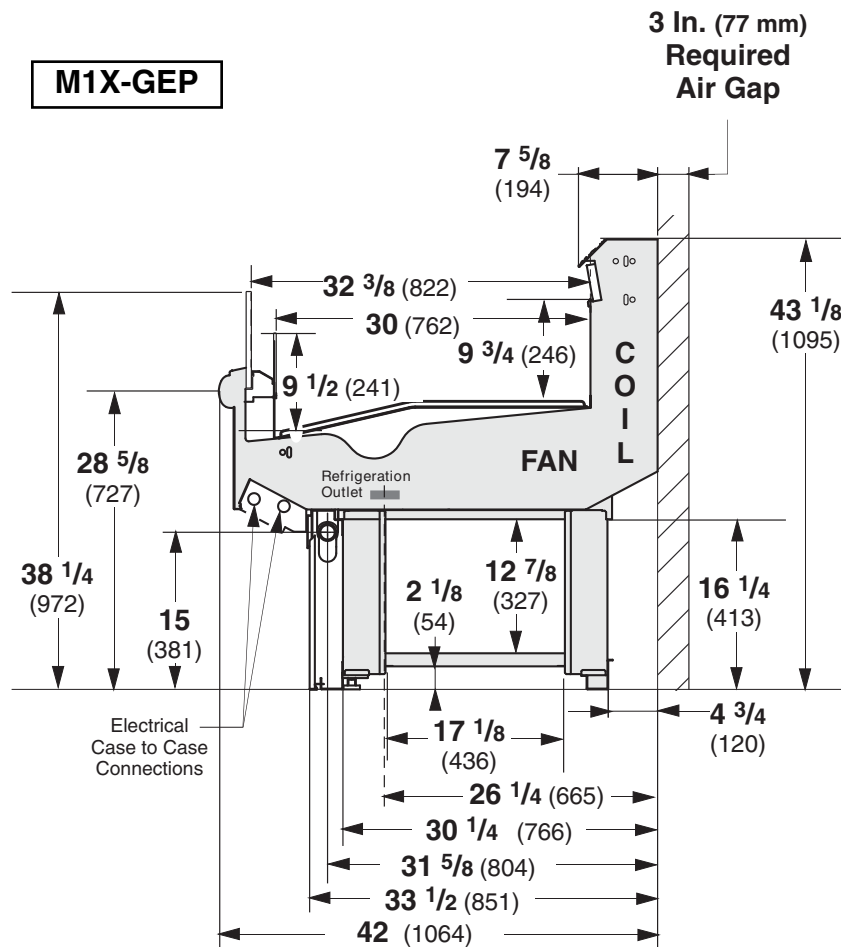

Impact Excel M1X-GEP
Meat, Delicatessen
Pre-cut and Packaged Produce

REFRIGERATION DATA

Note: This data is based on store temperature and humidity that does not exceed 75°F and 55% R.H.

	MIX-GEP
Discharge Air (°F)	30
Evaporator (°F)	26
Unit Sizing (°F)	24
Btu/hr/ft [‡]	MIX-GEP
Parallel	335
Conventional	350

‡Optional energy efficient motors reduce the refrigeration load by 14 Btu/hr/ft.

DEFROST DATA

	MIX-GEP
Frequency (hr)	12
Defrost Water (lb/ft/day)	2
(± 15% based on case configuration and product loading).	

OFF TIME	MIX-GEP
Time (minutes)	40

ELECTRIC OR GAS Not Recommended

CONVENTIONAL CONTROLS

Low Pressure Backup Control	MIX-GEP
CI/CO**	14°F / 8°F

Indoor Unit Only, Pressure Defrost Termination*	48°F
---	------

*Use a Temperature Pressure Chart to determine PSIG conversions.

Estimated Charge (lb)**	MIX-GEP
4 ft 1.0 lb 16 oz	0.4 kg
6 ft 1.4 lb 22 oz	0.6 kg
8 ft 2.0 lb 32 oz	0.9 kg
12 ft 2.6 lb 42 oz	1.2 kg

**This is an average for all refrigerant types. Actual refrigerant charge may vary by approximately half a pound.

NSF Certification

This merchandiser model is manufactured to meet ANSI/NSF (National Sanitation Foundation) Standard #7 requirements for construction, materials & cleanability.

Impact <i>Excel</i> M1X-GEP Meat, Delicatessen Precut and Packaged Produce

Electrical Data

	4 ft	6 ft	8 ft	12 ft
Number of Fans—4W	1	2	2	3

			Amperes				Watts			
			4 ft	6 ft	8 ft	12 ft	4 ft	6 ft	8 ft	12 ft
Evaporator Fan										
120V	60Hz	Standard	0.31	0.62	0.62	0.93	24	48	48	72
120V	50Hz	Standard	0.38	0.76	0.76	1.14	27	54	54	81
230V	60Hz	Export	0.15	0.30	0.30	0.45	24	48	48	72
230V	50Hz	Export	0.18	0.36	0.36	0.54	27	54	54	81
120V	60Hz	Energy Efficient	0.12	0.24	0.24	0.36	8	16	16	24
230V	60Hz	Energy Efficient	0.06	0.12	0.12	0.18	8	16	16	24

Minimum Circuit Ampacity

120V	60Hz	Standard	0.51	0.82	0.82	1.13
120V	50Hz	Standard	0.58	0.96	0.96	1.34
230V	60Hz	Export	0.35	0.50	0.50	0.65
230V	50Hz	Export	0.38	0.56	0.56	0.74
120V	60Hz	Energy Efficient	0.32	0.44	0.44	0.56
230V	60Hz	Energy Efficient	0.26	0.32	0.32	0.38

Maximum Over Current Protection 120V	20	20	20	20
Maximum Over Current Protection 230V	15	15	15	15

Impact Excel M1X-GEP
Meat, Delicatessen
Pre-cut and Packaged Produce

Product Data

<i>Recommended Usable Cube</i> ¹ (Cu Ft/Ft)	1.52 ft ³ /ft (0.14 m ³ /m)
<i>AHRI Total Display Area</i> ² (Sq Ft/Ft)	2.62 ft ² /ft (0.80 m ² /m)
<i>Shelf Area</i> ³ (Sq Ft/Ft)	2.51 ft ² /ft (0.76 m ² /m)

- ¹ AHRI Refrigerated Volume less shelving and other unusable space: Refrigerated Volume/Unit of Length, ft³/ft [m³/m]
- ² Computed using AHRI 1200 standard methodology: Total Display Area, ft² [m²]/Unit of Length, ft [m]
- ³ Shelf surface area is composed of bottom deck plus standard shelf complement, as shown in the Hussmann *Product Reference Guide*. The standard shelf complement for this model is NONE.

ESTIMATED SHIPPING WEIGHT ⁴					
Case	4 ft	6 ft	8 ft	12 ft	Solid End
					<i>(each)</i>
lb (kg)	400 (181)	500 (227)	700 (318)	900 (408)	50 (23)

⁴ Actual weights will vary according to optional kits included.

Fan Wiring
Offtime Defrost

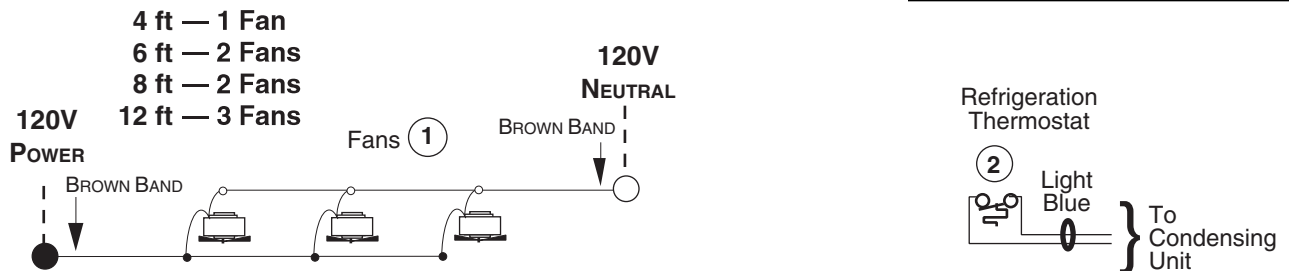

WARNING

All components must have mechanical ground, and the merchandiser must be grounded.

CIRCLED NUMBERS = PARTS LIST ITEM NUMBERS

GRAYED COMPONENTS IN 12 FOOT MODELS ONLY.

● = 120V POWER ○ = 120V NEUTRAL