

PARTS LIST

Item	Quantity	Description
1.	2	Gasket Tape 1/2 x 1/2 x 120
2.	2	Gasket Tape 15/8 x 1/2 x 180
3.	8	Flat Washer
4.	8	Lock Washer
5.	4	Lock Nut
6.	6	Cap Screw 5/16 x 18 x 2 1/2
7.	2	Nut Retainers
8.	2	Top Rail Trim
9.	4	Self-Tapping Sheet Metal Screw 10-16 x 3/4
10.		Silicone Sealer
11.	43	Sheet Metal Screw 8 x 1/2
12.	6	Sheet Metal Screws 8 x 1 1/2

All equipment should be thoroughly examined for shipping damage before and during unloading.

This equipment has been carefully inspected at our factory. Any claim for loss or damage must be made to the carrier. The carrier will provide any necessary inspection reports and/or claim forms.

Every effort is made to ship all parts for the kit. The Hussmann Service Center can be reached by calling

- from U.S. & Canada 1-800-922-1919 •
- from Mexico 1-800-522-1900 •

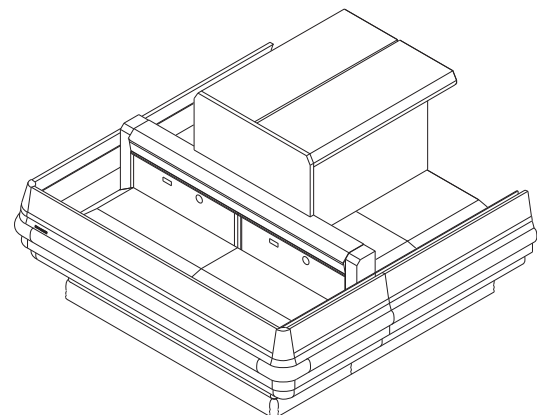

P/N 0509659_A
April 2009

1 REMOVE PACKAGING / POSITION C2LGE

Remove packaging. Remove all separately packed accessories such as kits and shelves. Remove end braces and discard hardware.

NOTE:

Joining instruction explains the procedure for installing one MIGLE-93 end merchandiser to two C2LGE parent merchandisers. If installing MIGLE-93 at opposite end of C2LGE lineup, follow same joining instructions for installing MIGLE-93 at opposing end.

Remove wire racks.

Remove return air grilles and deck pans.

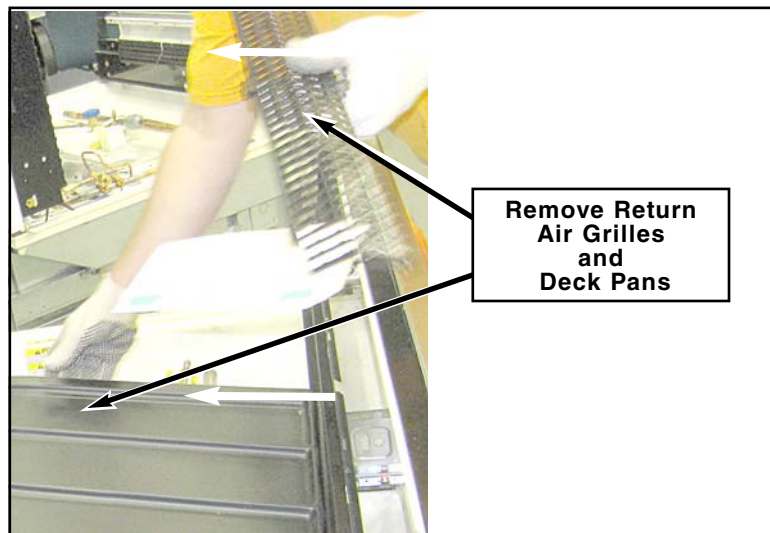
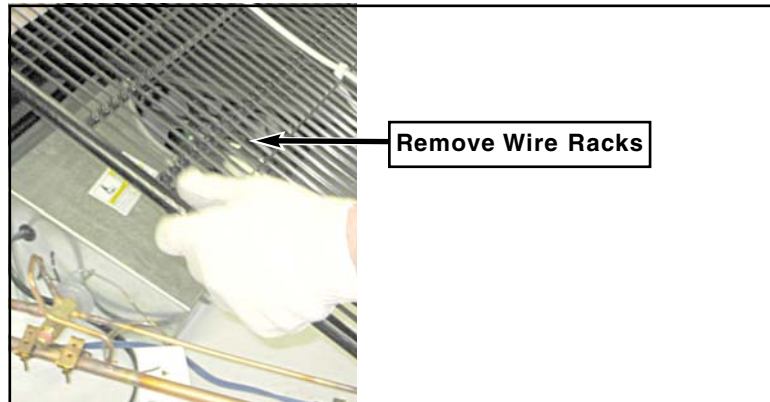
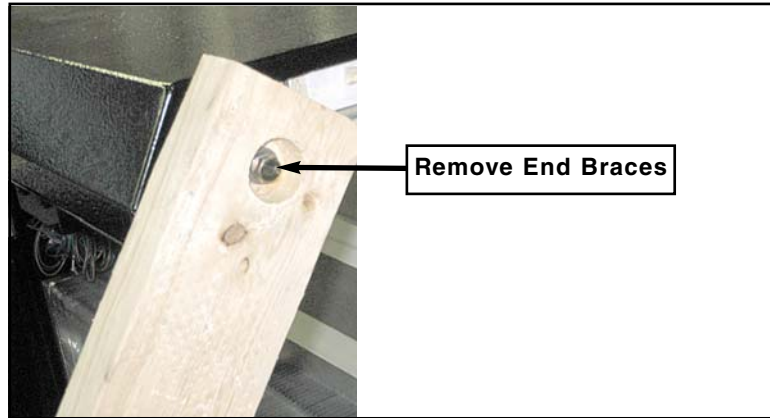

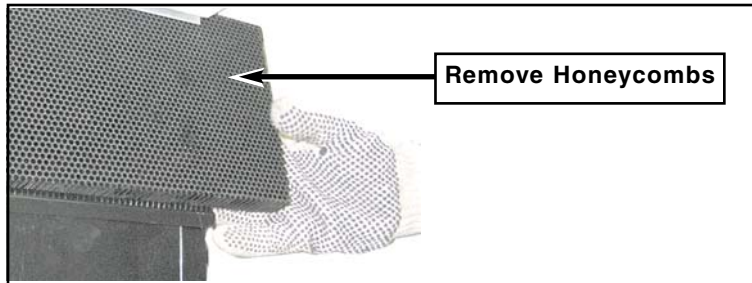

Remove honeycombs from each C2LGE merchandiser.

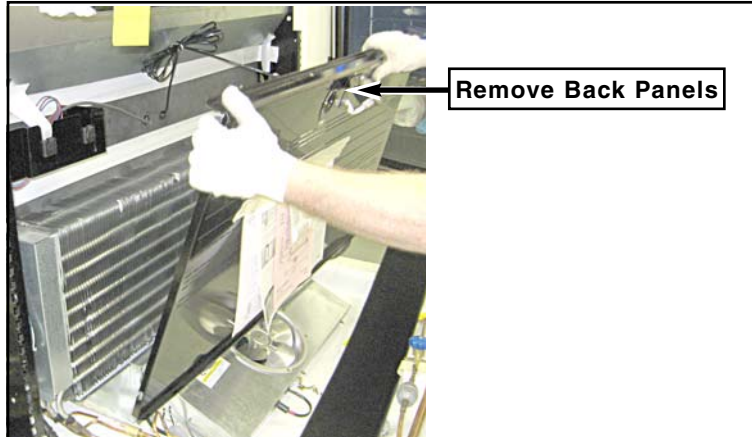

Remove back panels.

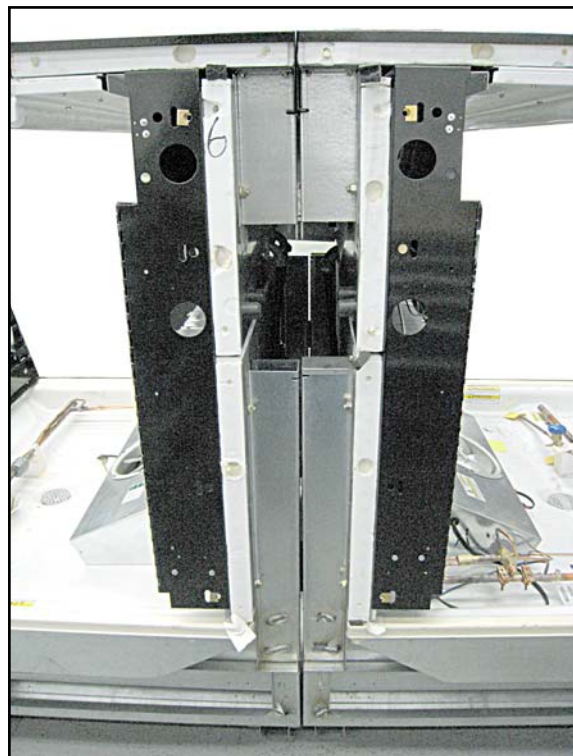

**Position C2LGE Parent Merchandisers
Back to Back**

Move both C2LGE parent merchandisers as close as possible to their permanent location facing back to back. Back to back gap between merchandisers should be approximately $\frac{5}{8}$ in. as measured from the canopy.

NOTE:

C2LGE must have a 4 in. elevated base kit applied to permit joining with the M1GLE-93. The height of each C2LGE merchandiser with the base kit is $51\frac{7}{8}$ in.

2 SHIM AND LEVEL C2LGE

Both C2LGE parent merchandisers must be level before joining the MIGLE-93 end merchandisers to ensure a proper fit and finish.

Use the provided metal shims to level the merchandisers as necessary. Place shims under front and back rails at cross-members. Check that merchandisers are level in the front and back and on each side.

Verify parent merchandisers align vertically and adjust shims as necessary.

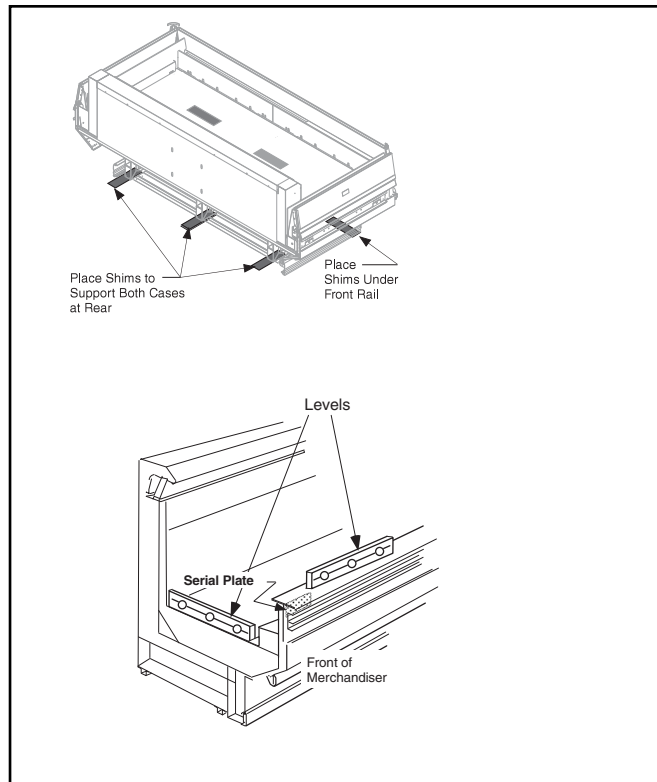

3 REMOVE NUT RETAINERS / CRIMP EQUALIZING TUBES

Remove bottom inboard nut retainers (2) from EACH END of C2LGE merchandisers. DO NOT remove any other nut retainers.

The front multi-glass assembly is equipped with air pressure equalizing tubes that are used during transit to prevent glass breakage from air pressure at high elevations. These equalizing tubes must be trimmed and crimped on all parent and end merchandisers. Remove tape, and cut off metal tubing 1 1/2 inches from rail. Crimp end and fold over to assure complete closure of tubes.

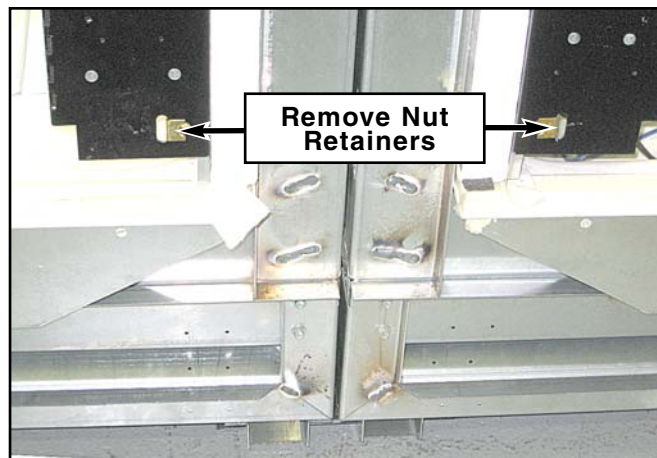

Cut and Crimp Equalizing Tubes

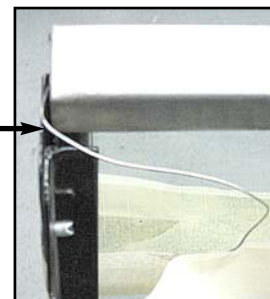

NOTE:
 Failure to properly crimp equalizing tubes will result in glass fogging.

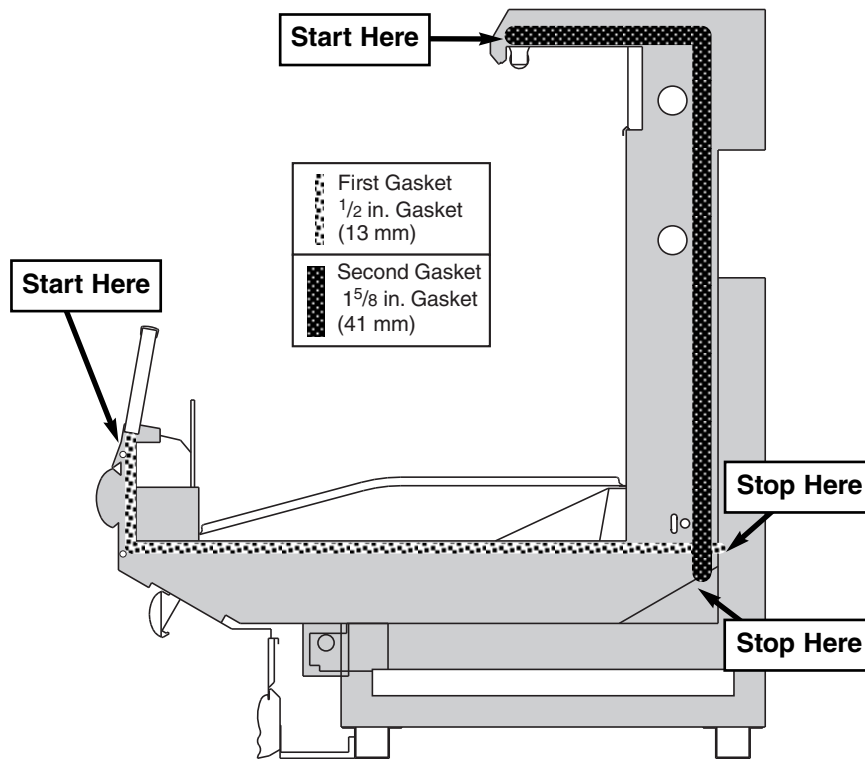

4 APPLY GASKETS TO C2LGE MERCHANDISERS

Apply 1/2 in. gasket around perimeter of C2LGE parent merchandisers at each end as shown in the illustration.

Apply 1 5/8 in. gasket so that one edge is on the metal merchandiser frame. Continue applying the gasket down to the foam bottom, overlapping the 1/2 in. gasket. Check that there are no gaps between merchandiser and gaskets.

IMPORTANT

- Do not stretch gasket, especially around corners.
- Do not butt gaskets; always overlap them as shown.
- Remove paper backing after gasket has been applied.
- *Perimeter gasket required by NSF.*

5 POSITION M1GLE-93 / REMOVE PACKAGING

Remove the plastic caps and lock nuts from the four joining bolts attached to the back of the M1GLE-93 merchandiser. Set the lock nuts aside — they will be used for joining.

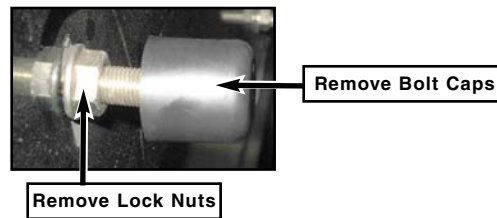

Move M1GLE-93 end merchandiser as close as possible to permanent location at the end of the C2LGE parent merchandisers. Remove packaging from M1GLE-93, and remove all separately packed accessories such as kits and shelves. Remove wire rack, display pan, return air grille, and back panel.



Position M1GLE-93 for Joining to C2LGE

6 SHIM AND LEVEL M1GLE

All merchandisers must be level before joining to ensure a proper fit and finish. Use the provided metal shims to level the M1GLE-93 end merchandiser as necessary. Place shims under front and back rail at cross-members. Check that merchandisers are level in the front and back, and on each side.

Verify all end merchandisers and parent merchandisers align at all joining points before attempting to join with lock nut and bolt.

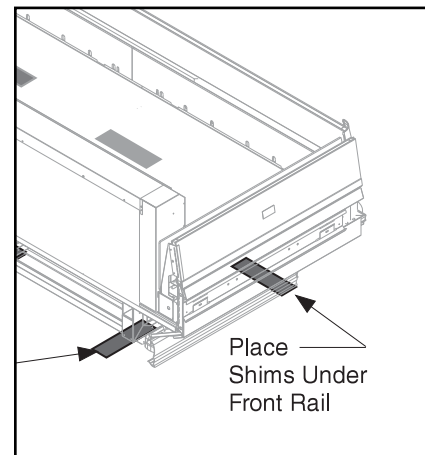
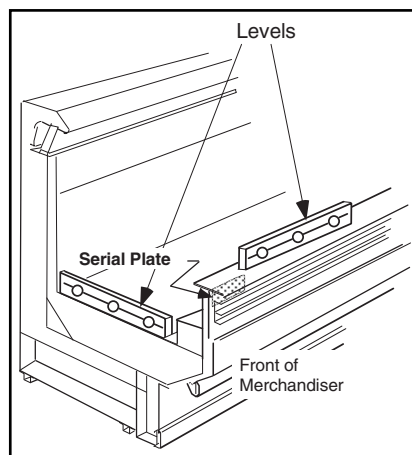

7 JOIN M1GLE-93 TO C2LGE PARENT MERCHANDISERS

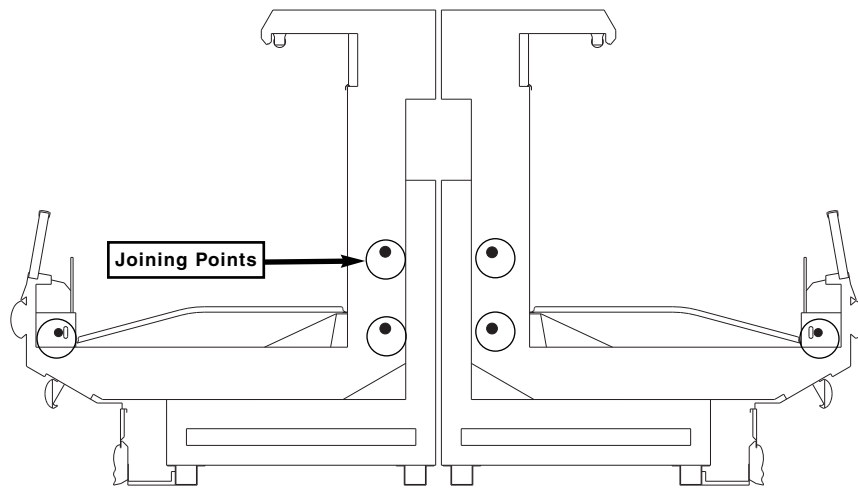

Two C2LGE back to back

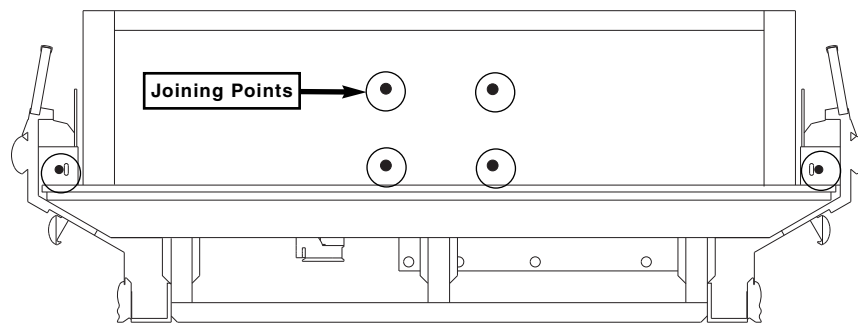

M1GLE-93

Align the four (4) joining bolts on the back of the M1GLE-93 merchandiser to the joining holes on the C2LGE merchandisers, and fasten the merchandisers together using Flat Washers (Item 3), Lock Washers (Item 4) and Lock Nuts (Item 5).

NOTE:

Use the lock nuts that were removed in Step 5.

Do not attempt to draw or pull merchandisers together using nut and bolt.

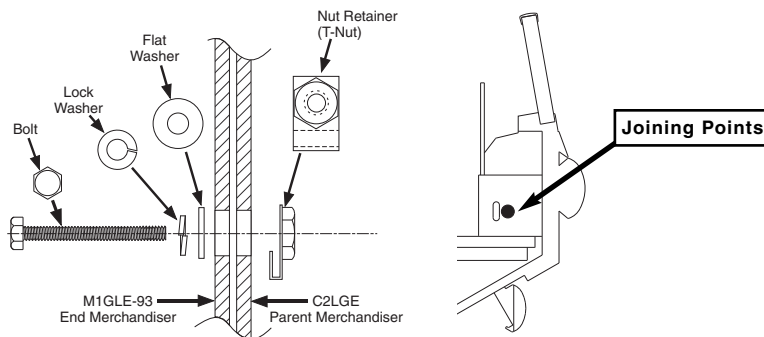

Insert Cap Screws (Item 6), Lock Washers (Item 4) and Flat Washers (Item 3) through the M1GLE-93 to C2LGE Nut Retainers (Item 7) at the end joining points as shown in the illustrations at left.

8 INSTALL TOP RAIL TRIM / FASTEN END BRACKETS

Remove the protective film from the stainless steel rails and top rail trim. Install the Top Rail Trim (Item 8) at all four locations. Top rail trim snaps in place over the joined rails.

Insert two (2) Self-Tapping Sheet Metal Screws (Item 7) through the end brackets located underneath top rail trims to ensure a good fit and finish for the stainless steel rails.

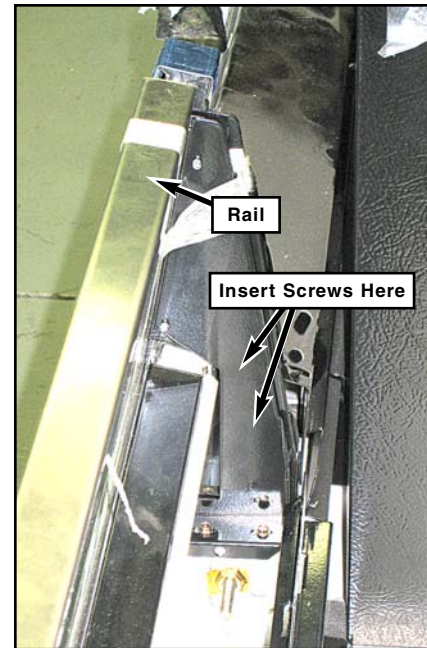
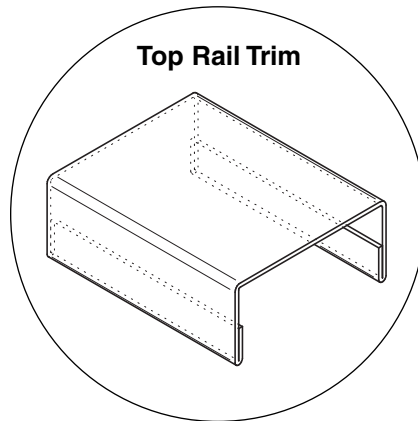

9 APPLY SILICONE SEALANT

Apply a continuous bead of Silicone Sealer (Item 8) to the inside of the C2LGE merchandisers where the M1GLE-93 cases were joined as shown in the illustration. **DO NOT** seal merchandisers until all joining points have been tightened and secured.

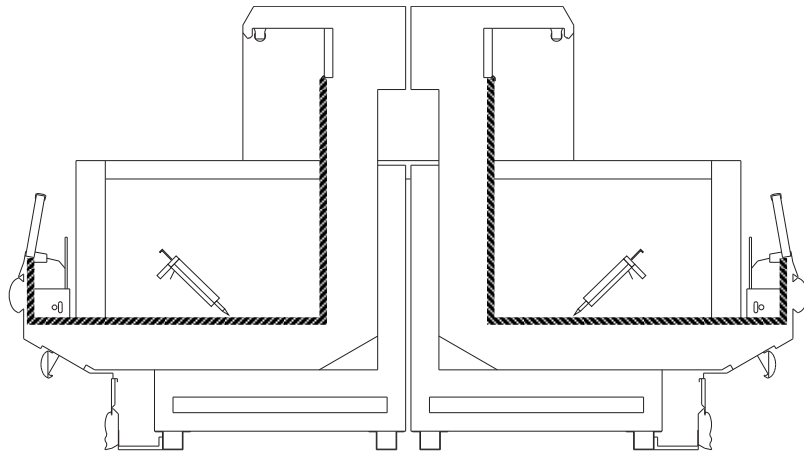

A continuous bead of silicone sealant / caulk may be used in addition to gaskets on mating surfaces but must not be used in lieu of gaskets.

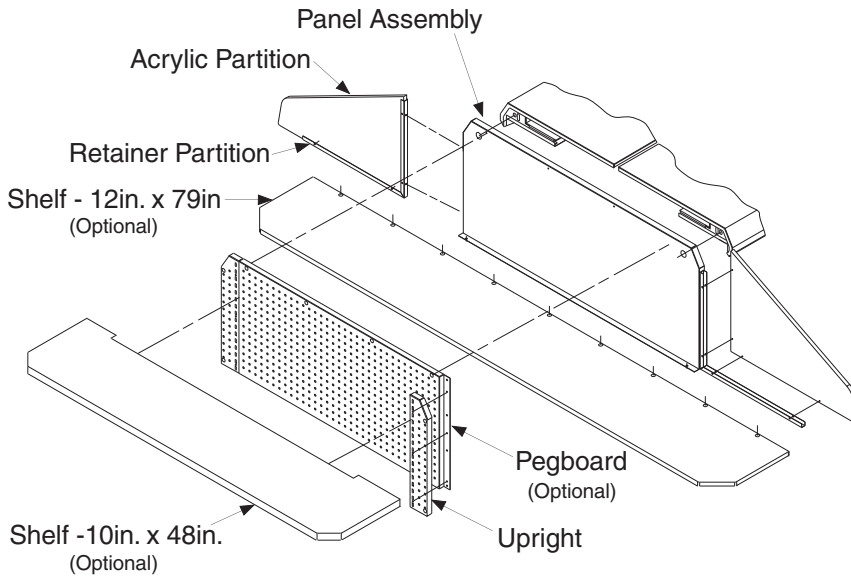

10 INSTALL PARTITION KIT

The partition kit may contain an optional pegboard and optional shelves, depending on the partition kit configuration that was ordered.

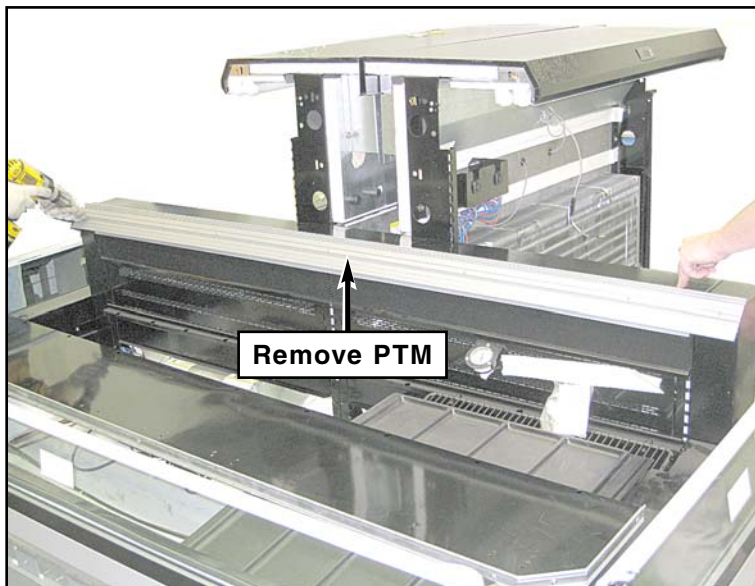

11 REMOVE PRICE TAG MOLDING (PTM)

NOTE:

Skip this step if 12 in. x 79 in. shelf is not to be installed or not included with partition kit.

Before the partition kit may be installed, the Price Tag Molding (PTM) must be removed from each M1GLE-93 end merchandiser. To remove the PTM, remove all screws attaching it to the merchandiser.

12 INSTALL PARTITION KIT

To install partition kit, remove all screws attached to the partition kit. Once all screws are removed, remove optional pegboard from panel assembly.

NOTE:

Set these screws aside, they will be used for installation.

Install Panel Assembly[Ⓐ] to C2LGE merchandiser canopies using two Cap Screws (Item 6), Lock Washer (Item 4) and Flat Washers (Item 3). Insert two (2) Sheet Metal Screws (Item 9) in bottom of panel assembly and into top exterior panel of end merchandiser. *Omit screws if optional shelf is to be installed.*

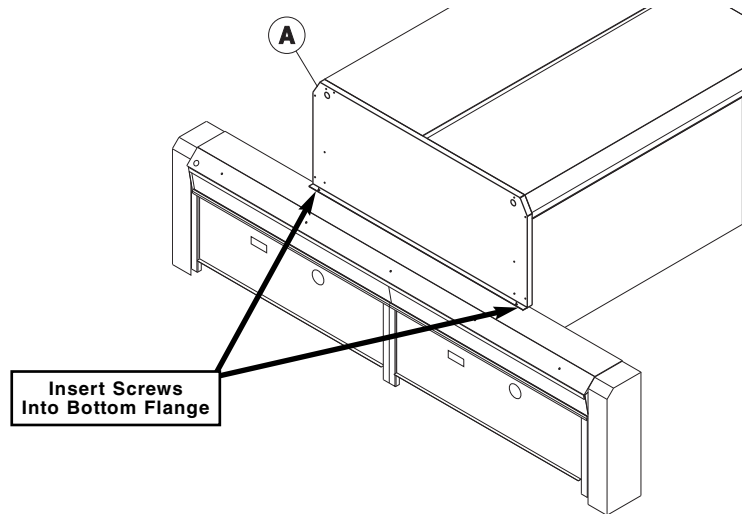
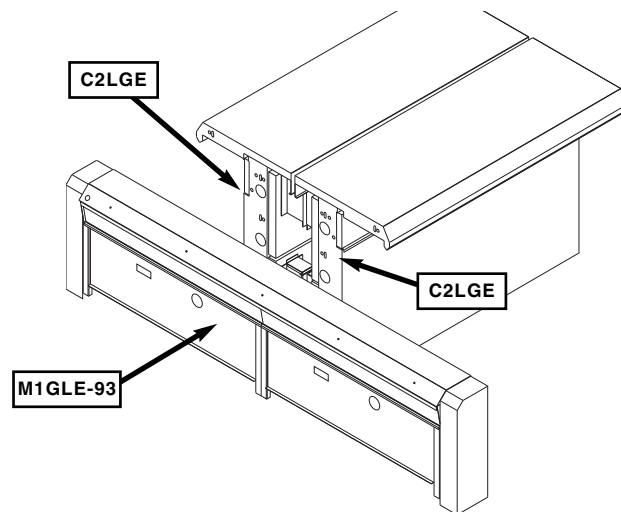

13 INSTALL PARTITION KIT

Insert 12 in. x 79 in. Shelf[Ⓑ]. Lay shelf on end merchandiser top exterior panel. Push back to face of panel assembly. Center on both sides. Secure with nine (9) Sheet Metal Screws (Item 9).

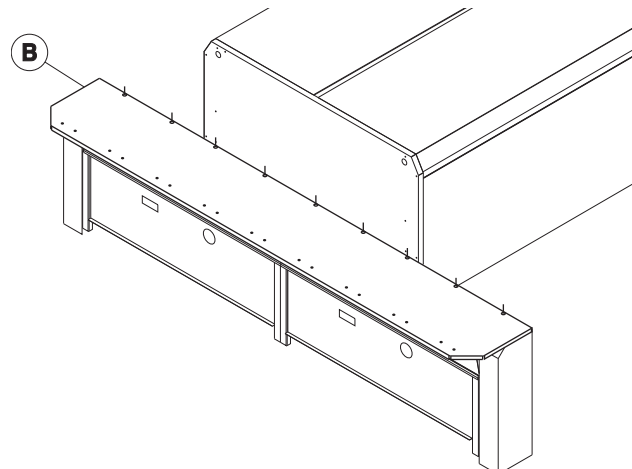

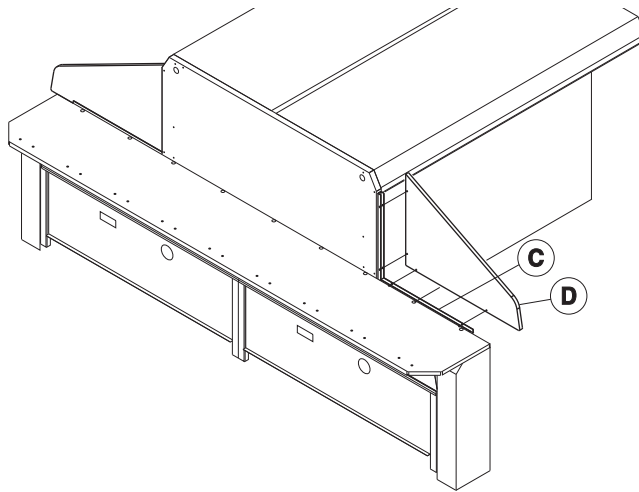

Install Retainer Partition © to panel assembly using two (2) Sheet Metal Screws (Item 9) for each side. Install one retainer partition to each side of panel assembly as shown.

Install Acrylic Partition © to retainer partition using four (4) Sheet Metal Screws (Item 9) for each side. Install one acrylic partition to each side of panel assembly as shown.

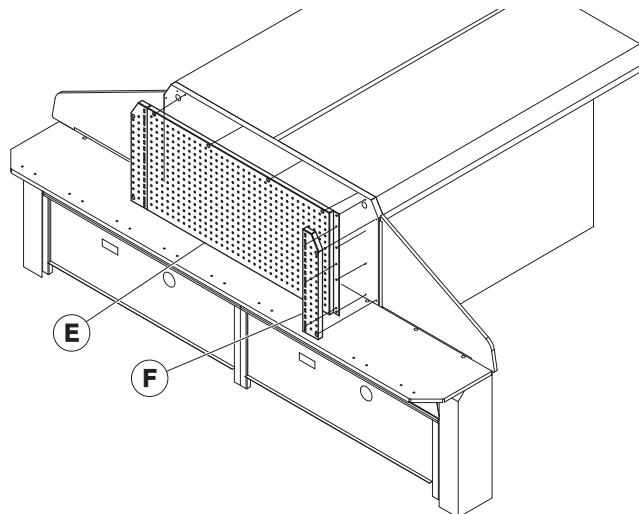

Install optional Pegboard © using four (4) Sheet Metal Screws (Item 9) across top of pegboard and four (4) Sheet Metal Screws (Item 9) on each side of pegboard.

Install Uprights © with three (3) Sheet Metal Screws 8 x 1½ (Item 12) on the inboard sides and two (2) Sheet Metal Screws (Item 9) on the outboard sides of uprights.

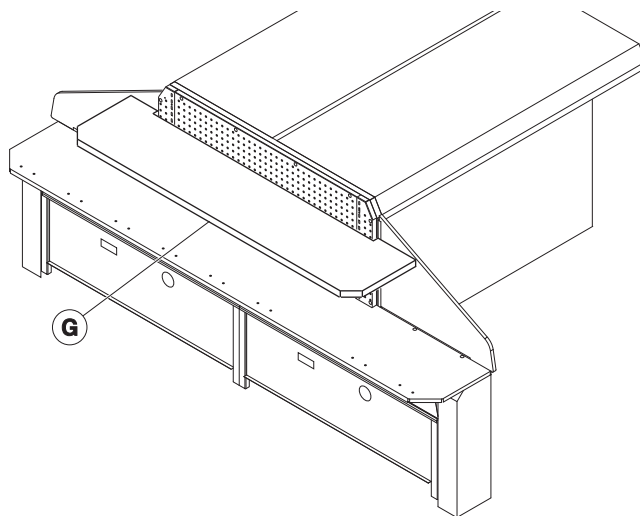

14 REMOVE BRACES / INSTALL BUMPERS

Remove M1GLE-93 corner shipping braces and discard hardware.

The top and bottom bumpers should be kept inside a cooler or refrigerated case for at least six (6) hours. This will allow the bumper to contract.

Measure and cut top bumper and bottom bumper. Use a miter box and fine-tooth saw to cut bumpers to length. Install the top and bottom bumpers.

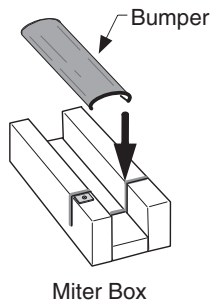

Remove protective film from the bumpers once installation is complete.

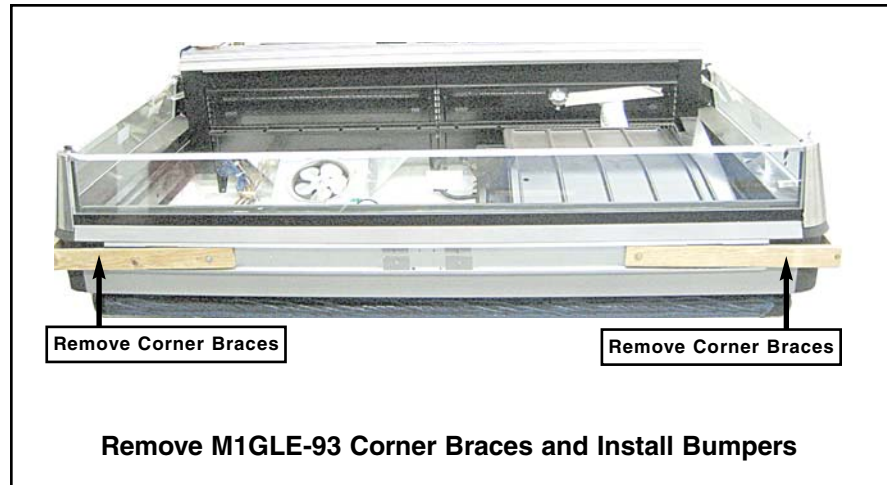

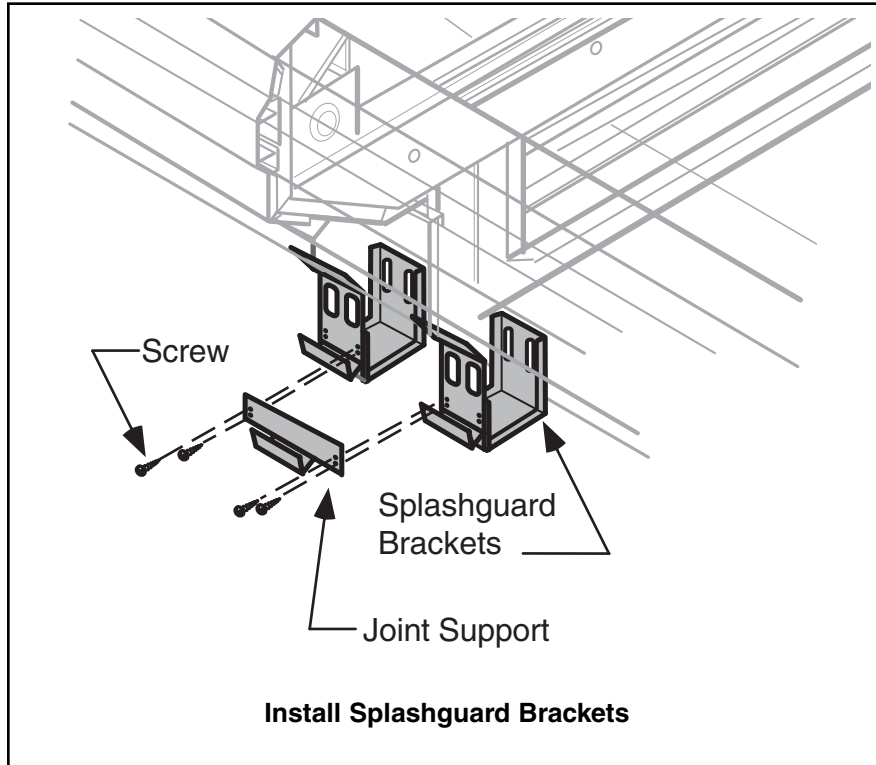

15 INSTALL SPLASHGUARDS

Attach the Splashguard brackets to side of legs using provided screws.

Install splashguards. Adjust to minimize any gap at joint.

1. Check to be sure that all splashguard brackets are level with the floor.
2. Position top of splashguard over the top edge of the bracket as shown below.
3. Push the lower edge of the splashguard toward the bottom of the bracket until it snaps into place.

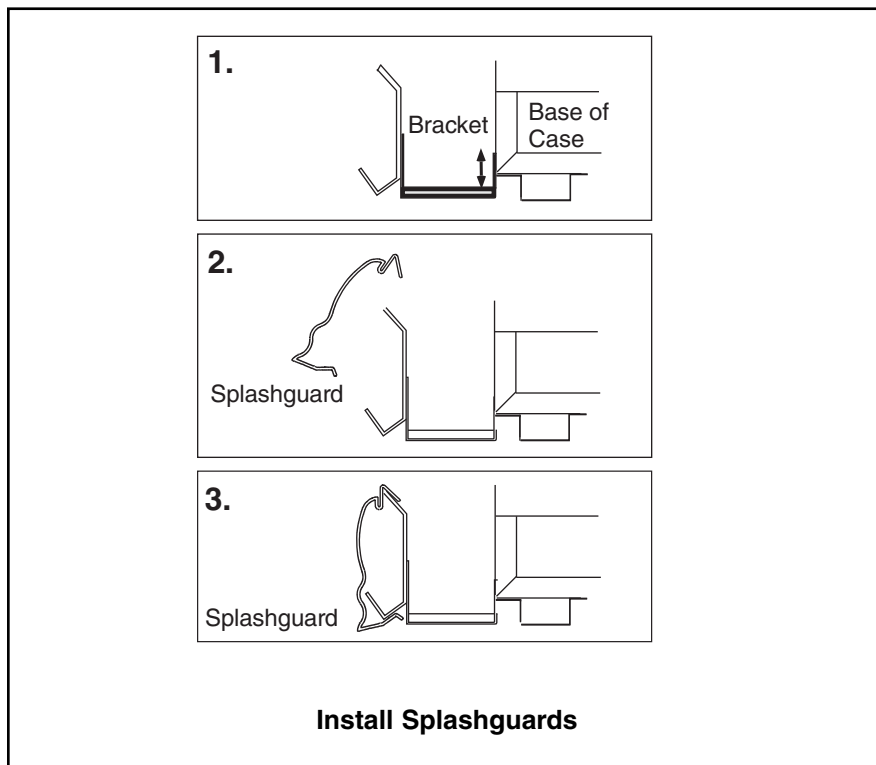

16 RE-INSTALL HARDWARE

Re-install all removed parts in reverse order of disassembly.

Overlap 2-ft deck pan as shown.



Re-install shelf supports as shown.

