

We reserve the right to change or revise specifications and product design in connection with any feature of our products. Such changes do not entitle the buyer to corresponding changes, improvements, additions or replacements for equipment previously sold or shipped.

**Warning:**  
**Terminal block NOT for case-to-case wire connection!**

Item	Part #	Description	Wiring Item #	Item	Part #	(Qty)	Description	Wiring Item #
<b>FAN ASSEMBLIES, AND THERMOSTATS</b>				<b>LED FIXTURES AND POWER SUPPLY</b>				
A.	<b>12W Standard</b>	Fan Assembly	(1)	J.	EP.4481668		Power Supply	(10)
	MO.4410103	Fan Motor, Evaporator		K.			Door Lamp, LED	
	FB.4780446	Fan Blade		<b>ECO SHINE</b>				
	<b>12W Optional Energy Efficient</b>	Fan Assembly	(1)	BU.4441328	3500K	Standard Angle	60-in. Center	(11)
	MO.4410546	Fan Motor, Evaporator		BU.4441330	4100K	Standard Angle	60-in. Center	(11)
	FB.4780446	Fan Blade		BU.4441329	3500K	Standard Angle	60-in. End	(12)
B.	CT.4440726	Standard Non-adjustable Defrost Thermostat	(2)	BU.4441331	4100K	Standard Angle	60-in. End	(12)
C.	<u>Optional Adjustable Refrigeration Thermostat</u>		(3)	BU.4441644	3500K	Wide Angle	60-in. Center	(11)
D.	CT.4440261	Defrost Limit Thermostat	(4)	BU.4441646	4100K	Wide Angle	60-in. Center	(11)
E.	CT.4481296	Relay Control Thermostat or Fan and Anti-sweat Heater Thermostat	(5)	BU.4441645	3500K	Wide Angle	60-in. End	(12)
				BU.4441647	4100K	Wide Angle	60-in. End	(12)
<b>RELAYS</b>				<b>ECO SHINE EP (ENERGY PLUS)</b>				
F.	RL.4480238	Anti-Sweat Control Relay (120V)	(6)	BU.4441394	3500K	Standard Angle	60-in. Center	(11)
G.	Fan Control Relay		(7)	BU.4441396	4100K	Standard Angle	60-in. Center	(11)
	RL.4480237	(208V) Electrical Defrost		BU.4441395	3500K	Standard Angle	60-in. End	(12)
	RL.4480238	(120V) KoolGas Defrost		BU.4441397	4100K	Standard Angle	60-in. End	(12)
<b>HEATERS</b>				BU.4441648	3500K	Wide Angle	60-in. Center	(11)
H.	Electric Defrost Heaters – Front (208V)		(8)	BU.4441650	4100K	Wide Angle	60-in. Center	(11)
	HE.4850346	(1) 2 Door Models		BU.4441649	3500K	Wide Angle	60-in. End	(12)
	HE.4850337	(1) 3 Door Models		BU.4441651	4100K	Wide Angle	60-in. End	(12)
	HE.4850347	(1) 4 Door Models		<b>L. Facade Lamp, LED</b>				
	HE.4850323	(1) 5 Door Models		BU.4441411	2900K	29.5 In. Length		(13)
	Electric Defrost Heaters — Rear (208V)		(8)	BU.4441412	2900K	30.5 In. Length		
	HE.4850358	(1) 2 Door Models		<b>Refer to INNOVATOR REACH-IN GLASS DOOR INSTALLATION AND SERVICE manual, P/N 0425683, for Innovator and Innovator II door and frame replacement parts.</b>				
	HE.4850359	(1) 3 Door Models						
	HE.4850360	(1) 4 Door Models						
	HE.4850361	(1) 5 Door Models						
I.	Drain Pan Heater — Electric & KoolGas (120V)		(9)					
	HE.4850239	(1) 2 Door Models						
	HE.4850240	(1) 3 Door Models						
	HE.4850241	(1) 4 Door Models						
	HE.4850242	(1) 5 Door Models						

**NOTE:** Revision B updates pages 1, 3, 4, 5 and 7. Changes are underlined, circled or marked with a vertical line in the margin.



# Engineering Plan Views

Reach-In  
2, 3, 4 & 5 Door

## LifeLine Premier RLNI Plan View 09-2009

### PHYSICAL DATA

Merchandiser Drip Pipe (in.)	1 1/4
Merchandiser Liquid Line (in.)	3/8
Merchandiser Suction Line (in.)	7/8

Dimensions shown as inches and (mm).

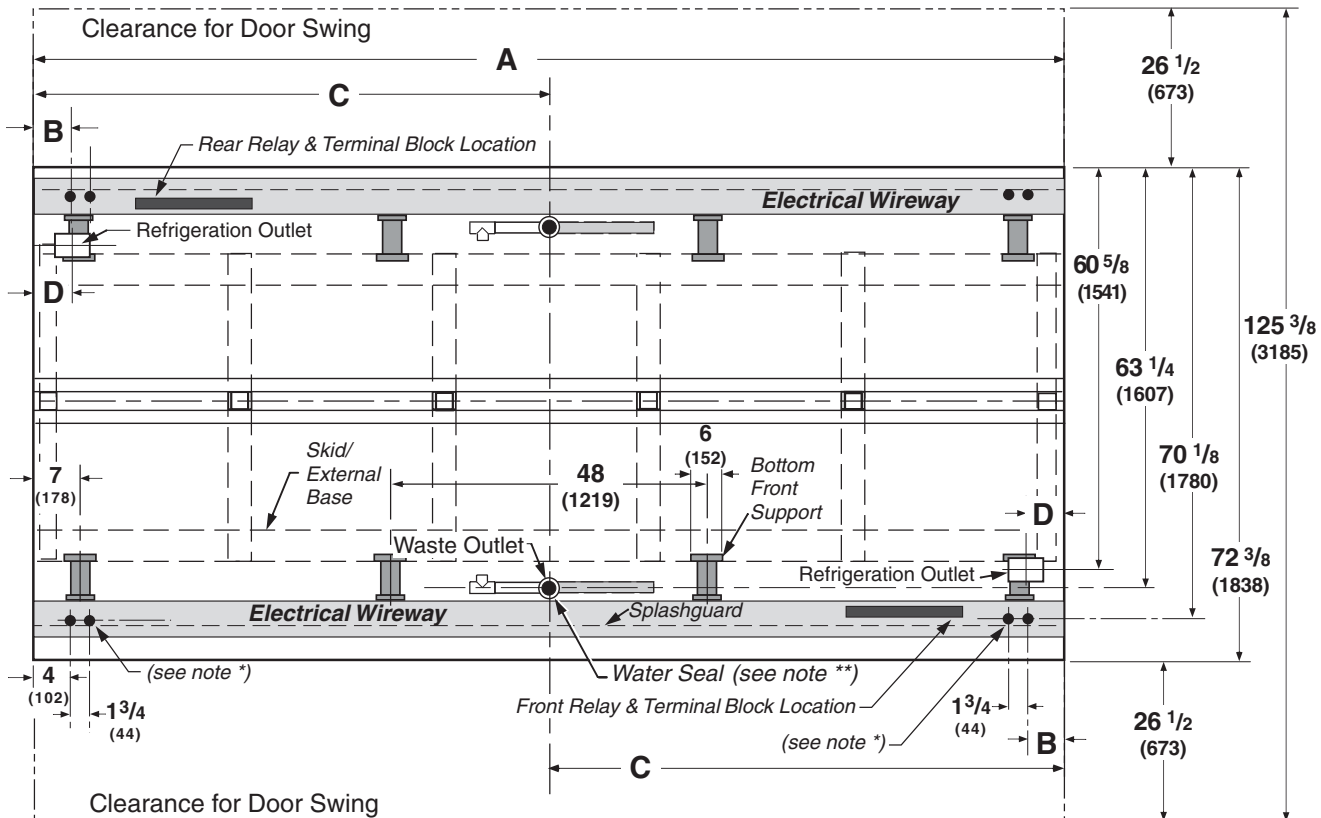





Front  
5-Door Shown

Base 5-door merchandiser is shown above, without Partitions or Ends. Dry Goods cabinets and Bump Out not available on island models. Refer to chart on Page 3 for detailed dimensional information on options.

**Plan View Dimensions for  
LifeLine Premier Options**

**LifeLine Premier RLNI**  
With INNOVATOR Doors  
Frozen Food & Ice Cream

	2 Dr	3 Dr	4 Dr	5 Dr
<b>General</b>				
<b>(A)</b> Merchandiser Length	62 (1575)	92 1/2 (2350)	122 7/8 (3121)	153 3/8 (3896)
Maximum O/S dimension of merchandiser back to front ***	72 3/8 (1838)	72 3/8 (1838)	72 3/8 (1838)	72 3/8 (1838)
*** Includes bumper. Add 53 in. (1346 mm) for door swing.				
Width of Skid rail	3 3/4 (95)	3 3/4 (95)	3 3/4 (95)	3 3/4 (95)
Width of Bottom Front Support	6 (152)	6 (152)	6 (152)	6 (152)
Stub-up area between front support and splashguard	3 1/8 (79)	3 1/8 (79)	3 1/8 (79)	3 1/8 (79)
<b>Electrical Service</b> 				
<b>(B)</b> RH end of merchandiser to the center of nearest knockout	4 (102)	4 (102)	4 (102)	4 (102)
RH end of merchandiser to the center of LH knockout	58 (1473)	88 1/2 (2248)	118 7/8 (3019)	149 3/8 (3794)
* NOTE: Electrical Field Wiring Connection Point is at terminal.				
<b>Waste Outlet</b> 				
<b>(C)</b> Right end of merchandiser to center of waste outlet	<u>23 7/8 (606)</u>	54 1/4 (1378)	46 1/4 (1175)	76 5/8 (1946)
<b>Water Seal</b> 				
Edge of water seal to center of waste outlet	<u>13 (330)</u>	<u>13 (330)</u>	<u>13 (330)</u>	<u>13 (330)</u>
Schedule 40 PVC drip pipe	1 1/4 (32)	1 1/4 (32)	1 1/4 (32)	1 1/4 (32)
** NOTE: Field installed water seal outlets, tees, and connectors are shipped with merchandiser.				
<b>Refrigeration Outlet</b> 				
<b>(D)</b> RH end of merchandiser to center of RH refrigeration outlet	5 3/8 (136)	5 3/8 (136)	5 3/8 (136)	5 3/8 (136)
Back O/S of merchandiser to center of refrigeration outlet	60 5/8 (1541)	60 5/8 (1541)	60 5/8 (1541)	60 5/8 (1541)
Outside bottom front supports from end of merchandiser	7 (178)	7 (178)	7 (178)	7 (178)
Distance between centerlines of Center bottom front support	48 (1219)	48 (1219)	48 (1219)	48 (1219)
Distance between Center and Outside supports will vary				

# LifeLine Premier RLNI

With INNOVATOR Doors  
Frozen Food & Ice Cream

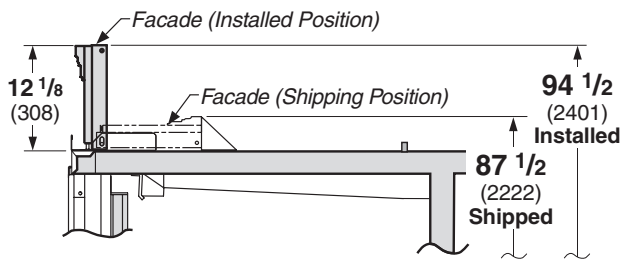

12 in. Straight Facade

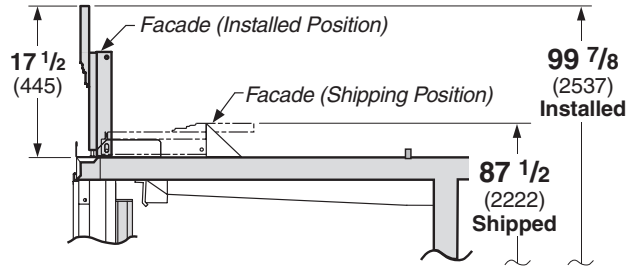

12 in. Arch Facade

## Facade Options in Cross Section

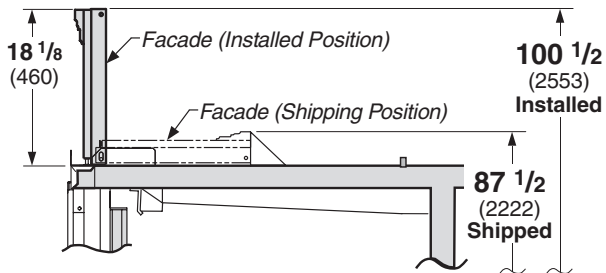

18 in. Straight Facade

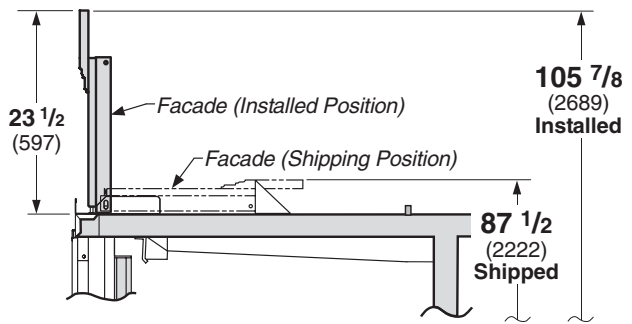

18 in. Arch Facade

# LifeLine Premier Narrow Island Reach-in 2, 3, 4 and 5 Door Models

Dimensions shown as inches and (mm).

**LifeLine Premier RLNI**

**See Page 4 for alternate facade heights.**

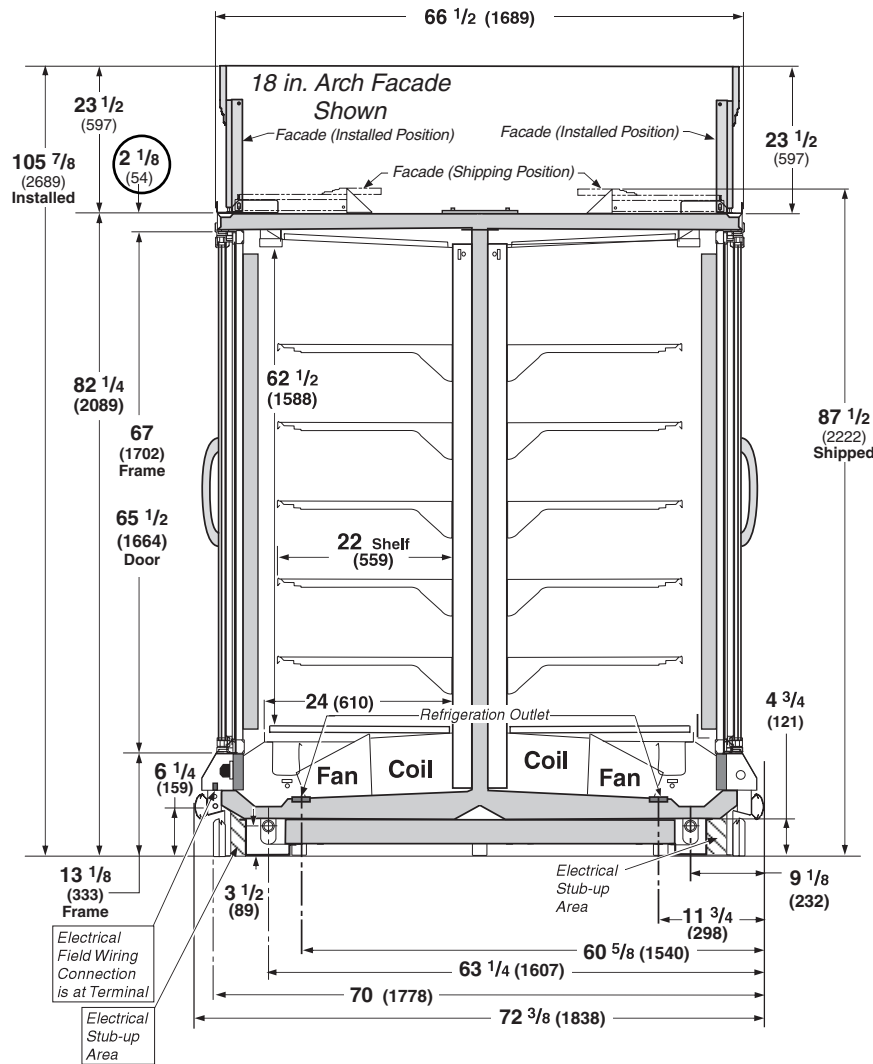

## NSF Certification

This merchandiser model is manufactured to meet ANSI/NSF (National Sanitation Foundation) Standard #7 requirements for construction, materials & cleanability.

**LifeLine Premier RLNI**  
With INNOVATOR Doors  
Frozen Food & Ice Cream

**Refrigeration data is PER SIDE.**

## REFRIGERATION DATA

Note: This data is based on store temperature and humidity that does not exceed 75°F and 55% R.H.

	FF	IC
Discharge Air (°F)	-5	-12
Evaporator(°F)	-11	-19
Unit Sizing (°F)	-14	-22
Btu/hr/door/side *	FF	IC
Parallel	1080	1144
Conventional	1200	1270

\* Optional Energy Efficient Fan motors reduce refrigeration load by 109 Btu/hr/door/side.

## DEFROST DATA

	FF	IC
Frequency (hr)	24	24
Defrost Water (lb/Dr/side/day)	1.2	1.2
(± 15% based on case configuration and product loading).		
<b>ELECTRIC</b>	FF	IC
Temp Term (°F)	48°	48°
Failsafe (minutes)	45	45
<b>GAS</b>		
Duration (minutes)	20	20
<b>OFFTIME</b>	Not Recommended	

## CONVENTIONAL CONTROLS

### Low Pressure Backup Control

	FF	IC
CI/CO (Temp °F)**	-18°/-34°	-26°/-45°

### Indoor Unit Only, Pressure Defrost

Termination (Temp °F)\*\*

Not Recommended

\*\*Use a Temperature Pressure Chart to determine PSIG conversions.

### Estimated Charge per Side \*\*\*

<b>2Dr</b>	1.8 lb	29 oz	0.8 kg
<b>3Dr</b>	2.7 lb	43 oz	1.2 kg
<b>4Dr</b>	3.6 lb	58 oz	1.6 kg
<b>5Dr</b>	4.6 lb	74 oz	2.1 kg

\*\*\*This is an average for all refrigerant types. Actual refrigerant charge may vary by approximately 0.5 lb (8 oz / 0.2 kg).

**Hussmann recommends against frame heater cycling with Innovator doors to prevent door seals from freezing to the frames and tearing.**

**Electrical Data**      **ELECTRICAL DATA IS PER SIDE — TWO CIRCUITS REQUIRED PER CASE.**

			2Dr	3Dr	4Dr	5Dr				
Number of Fans—12W			2	3	4	5				
Merchandise			Amperes				Watts			
			2Dr	3Dr	4Dr	5Dr	2Dr	3Dr	4Dr	5Dr
<b>Evaporator Fan</b>										
120V	60Hz	Standard	1.30	1.95	2.60	3.25	100	150	200	250
120V	50Hz	Standard	1.50	2.25	3.00	3.75	114	171	228	285
220V	60Hz	Export	0.66	0.99	1.32	1.65	100	150	200	250
220V	50Hz	Export	0.76	1.14	1.52	1.90	114	171	228	285
120V	60Hz	Energy Efficient	0.60	0.90	1.20	1.50	36	54	72	90
220V	60Hz	Energy Efficient	0.30	0.45	0.60	0.75	36	54	72	90
<b>Door Anti-sweat Heaters (on fan circuit)</b>										
120V	50/60Hz	Standard	1.54	2.31	3.08	3.86	185	278	370	463
220V	50/60Hz	Export	0.84	1.26	1.68	2.10	185	278	370	463
<b>Frame Anti-sweat Heaters (on fan circuit)</b>										
120V	50/60Hz	Standard	0.78	1.18	1.57	1.97	94	141	188	236
220V	50/60Hz	Export	0.43	0.64	0.85	1.07	94	141	188	236
<b>Minimum Circuit Ampacity</b>										
120V	60Hz	Standard	3.82	5.64	7.45	9.28				
120V	50Hz	Standard	4.02	5.94	7.85	9.78				
220V	60Hz	Export	2.13	3.09	4.05	5.02				
220V	50Hz	Export	2.23	3.24	4.25	5.27				
120V	60Hz	Energy Efficient	3.12	4.59	6.05	7.53				
220V	60Hz	Energy Efficient	1.77	2.55	3.33	4.12				
<b>Maximum Over Current Protection 120V</b>			<b>20</b>	<b>20</b>	<b>20</b>	<b>20</b>				
<b>Maximum Over Current Protection 220V</b>			<b>15</b>	<b>15</b>	<b>15</b>	<b>15</b>				
<b>Defrost</b>										
Drain Heaters (120V)			0.63	1.25	2.00	2.50	75	150	240	300
(Export: 220V 50 hz)			0.39	0.76	1.22	1.53	84	168	269	336
<b>208V 1Ø Electric Defrost</b>										
			6.72	10.08	13.46	16.82	1400	2100	2800	3500
(Export: 220V 50 hz)			7.11	10.66	14.24	17.79	1564	2345	3133	3914
<b>Standard Vertical Lighting*</b>										
<b>Hussmann EcoShine™ (24VDC)</b>			<b>2Dr</b>	<b>3Dr</b>	<b>4Dr</b>	<b>5Dr</b>	<b>2Dr</b>	<b>3Dr</b>	<b>4Dr</b>	<b>5Dr</b>
			0.45	0.68	0.90	1.13	54	81	108	135
<b>Optional LED Lighting (24VDC)</b>										
<b>Facade Lamps</b>			0.79	1.17	1.54	1.92	19	28	37	46

\* Innovator or Innovator II.

**Product Data**      **PRODUCT DATA IS PER SIDE.**

<i>Recommended Usable Cube</i> <sup>1</sup> (Cu Ft/Dr)	22.80 ft <sup>3</sup> /Dr (0.65 m <sup>3</sup> /Dr)
<i>AHRI Total Display Area</i> <sup>2</sup> (Sq Ft/Dr)	13.31 ft <sup>2</sup> /Dr (1.24 m <sup>2</sup> /Dr)
<i>Shelf Area</i> <sup>3</sup> (Sq Ft/Dr)	28.50 ft <sup>2</sup> /Dr (2.65 m <sup>2</sup> /Dr)

- <sup>1</sup> AHRI Refrigerated Volume less shelving and other unusable space: Refrigerated Volume/Unit of Length, ft<sup>3</sup>/ft [m<sup>3</sup>/m]  
<sup>2</sup> Computed using AHRI 1200 standard methodology: Total Display Area, ft<sup>2</sup> [m<sup>2</sup>]/Unit of Length, ft [m]  
<sup>3</sup> Shelf surface area is composed of bottom deck plus standard shelf complement, as shown in the Hussmann *Product Reference Guide*. The standard shelf complement for this model is (5) rows of 22-inch shelves.

**ESTIMATED SHIPPING WEIGHT <sup>4</sup>**

	<i>2 Dr</i>	<i>3 Dr</i>	<i>4 Dr</i>	<i>5 Dr</i>	<b>Solid End (each)</b>
<b>Standard LifeLine Premier Merchandiser (12-Inch Facade, no Arch)</b>					
<b>lb (kg)</b>	1204 (546)	2320 (1052)	3094 (1403)	3868 (1454)	110 (50)
<b>Standard LifeLine Premier Merchandiser (18-Inch Facade, no Arch)</b>					
<b>lb (kg)</b>	1244 (564)	2380 (1080)	3174 (1440)	3968 (1800)	110 (50)

Add 10 lb (5 kg) for Arch each side

<sup>4</sup> Actual weights will vary according to optional kits included.

# Fan and Heater Circuits — Electric Defrost (standard) Low Temperature

**Wiring Diagram is per side — two circuits required per case.**

CIRCLED NUMBERS = PARTS LIST ITEM NUMBERS  
 R = Red P = Purple 2P = Purple (2 Bands) DB = Dark Blue BK = Black  
 LB = Light Blue Pink = Pink BR = Brown Y = Yellow OR = Orange W = White  
**THESE ARE MARKER COLORS (WIRE MAY VARY.)**

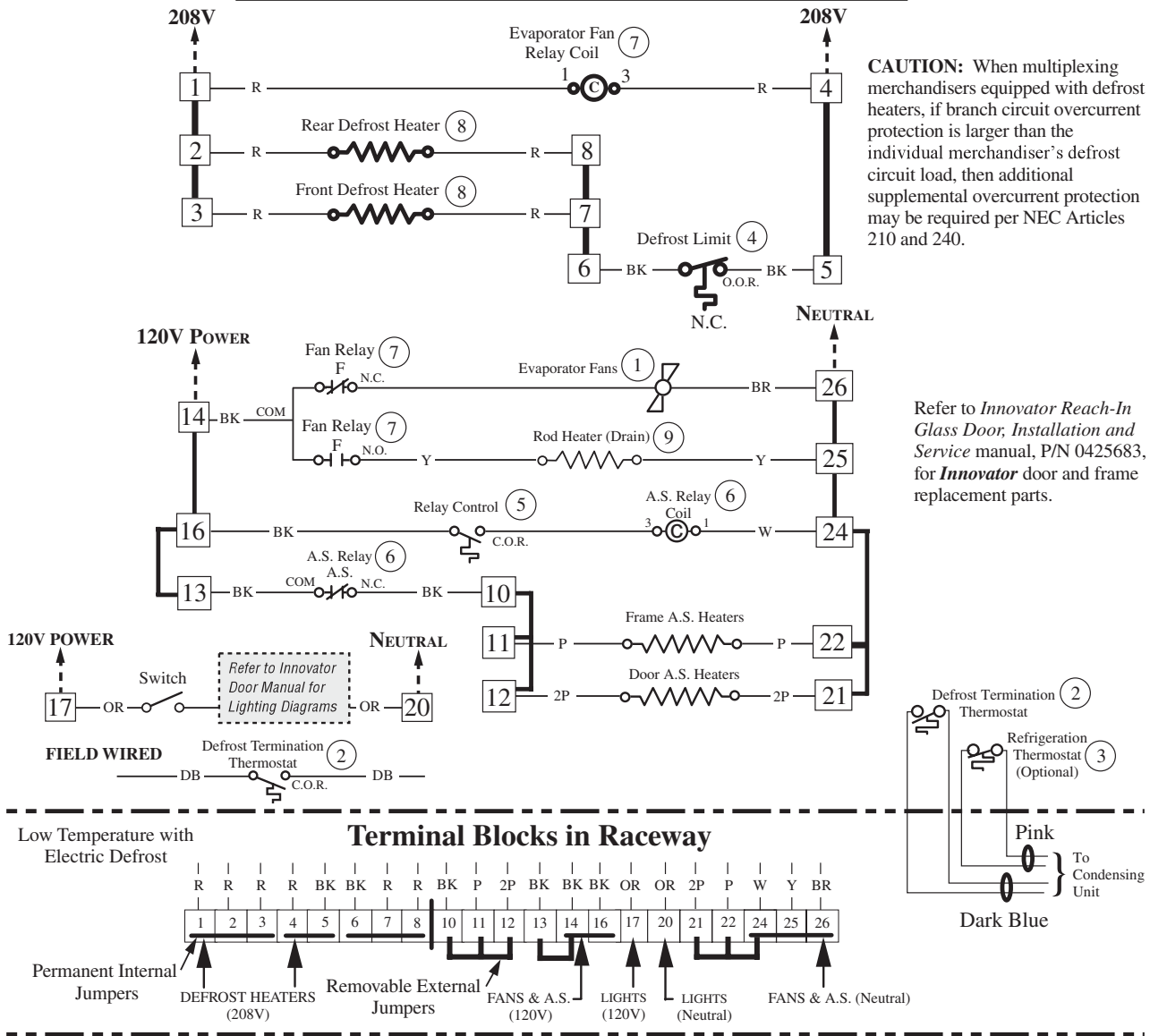

## Electric Defrost Sequence - Low Temperature

1. Power from the defrost contactor energizes Defrost Heaters and 208V Evaporator Fan Relay Coil (7). Relay Contacts open the fan circuit and energizes the Drain Pan Heater.
2. If the Defrost Heater raises internal air temperature above 90°F, the Defrost Limit Thermostat (4) will open.
3. Temperature rise of the evaporator closes the Relay Control Thermostat (5) at about 35°F, energizing 120V A.S. Relay Coil (6). This relay's contacts open the Frame and Door Heater Circuits.
4. When Defrost Termination Thermostat ends defrost period, the defrost contactor opens the Defrost Heater and Evaporator Fan Relay Coil Circuits. The Drain Pan Heater goes off and fans are on.
5. Temperature fall of the evaporator opens the Relay Control Thermostat (5) at about 20°F, de-energizing 120V A.S. Relay Coil (6). A.S. Relay Contacts close the Frame and Door Heater Circuits.

**Wiring Diagram is per side — two circuits required per case.**



# Fan and Heater Circuits — Gas Defrost (optional) Low Temperature

**Wiring Diagram is per side — two circuits required per case.**

CIRCLED NUMBERS = PARTS LIST ITEM NUMBERS  
 R = Red P = Purple 2P = Purple (2 Bands) DB = Dark Blue BK = Black  
 LB = Light Blue Pink = Pink BR = Brown Y = Yellow OR = Orange W = White  
**THESE ARE MARKER COLORS (WIRE MAY VARY.)**

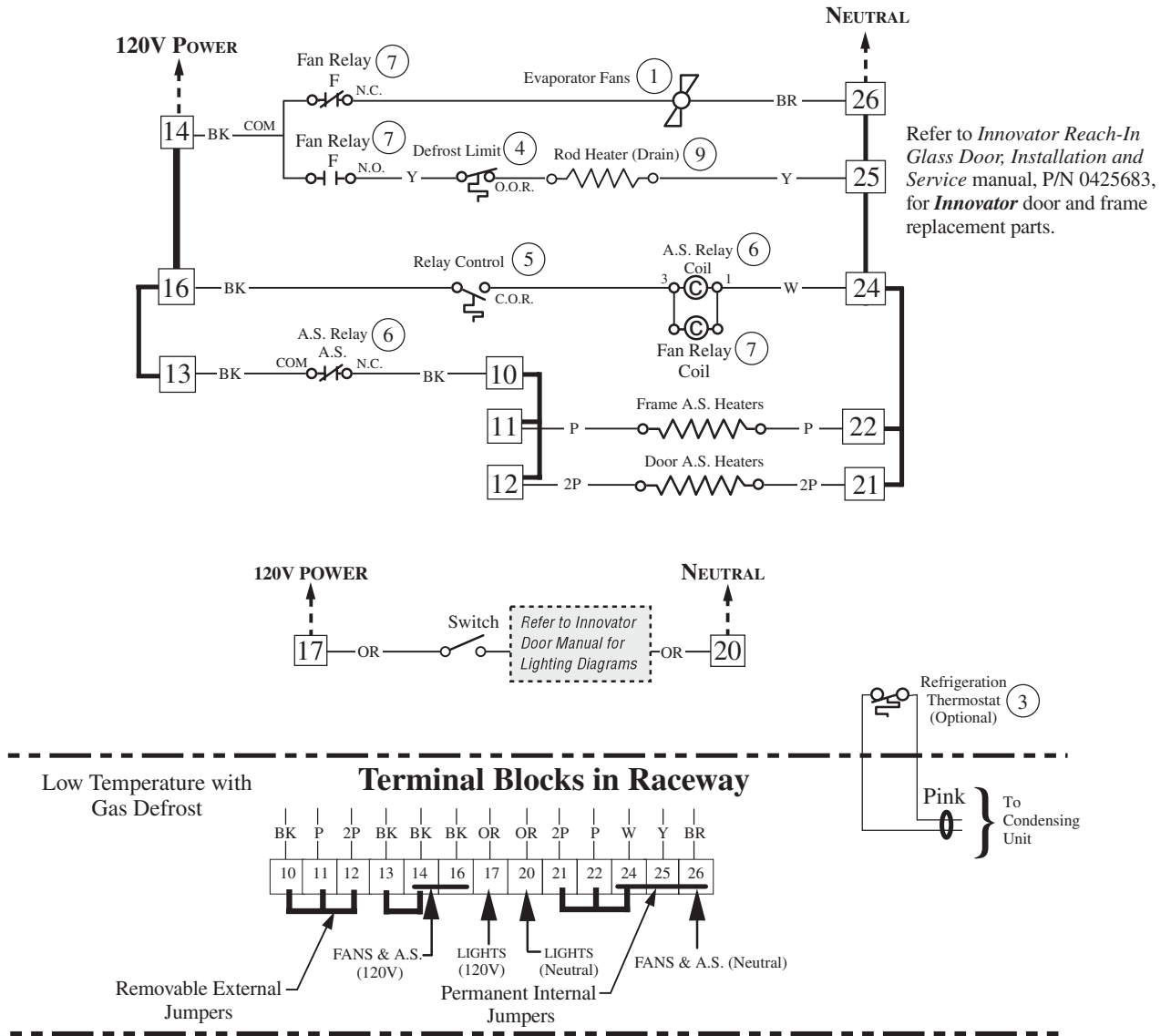

## Gas Defrost Sequence - Low Temperature

1. Defrost vapor enters evaporator causing a rise in temperature. At about 35°F the Control Relay Thermostat (5) closes the A.S. Relay Coil (6) and Fan Relay Coil (7) circuit. The Relay opens the Fan, Door Heater, and Frame Heater circuits, while energizing the Drain Pan Heater (9).
2. If the Drain Pan Heater (9) raises internal air temperature above 90°F, the Heater Limit Thermostat (4) will open.
3. When the defrost timer ends a defrost period, the evaporator temperature will start to fall. At about 20°F, the Relay Control Thermostat will open, de-energizing the A.S. Relay Coil (6) and Fan Relay Coil (7). The A.S. and Fan Relays will open the Drain Pan Heater circuits, and will close the Fan, Door Heater, and Frame Heater circuits.

**Wiring Diagram is per side — two circuits required per case.**

**Standard  
Vertical  
Lighting  
Husmann  
EcoShine™  
LED  
Fixtures**

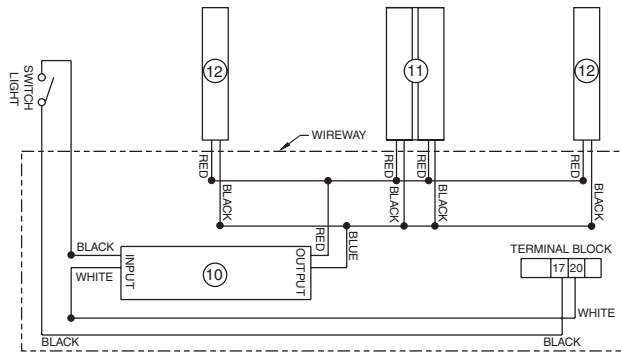

2 DOOR LED LIGHT WIRING DIAGRAM

**Wiring Diagram is per side — two circuits required per case.**

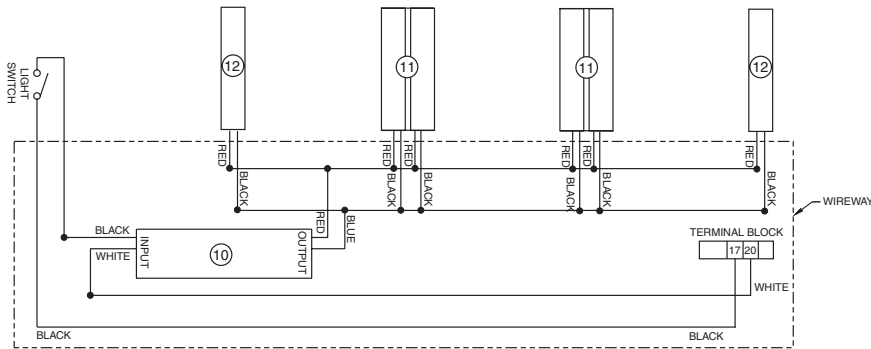

3 DOOR LED LIGHT WIRING DIAGRAM

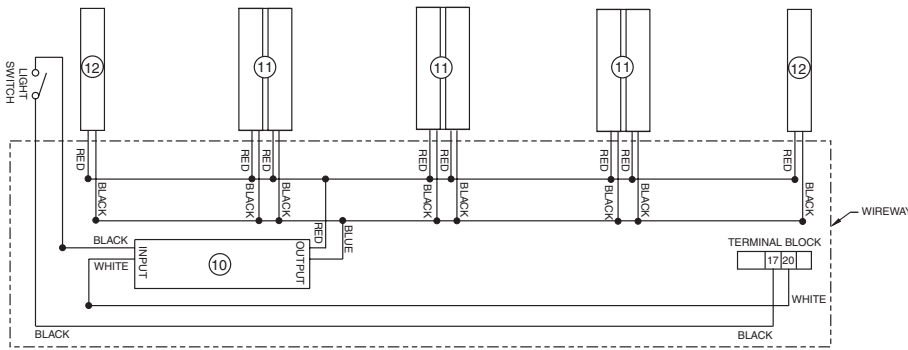

4 DOOR LED LIGHT WIRING DIAGRAM

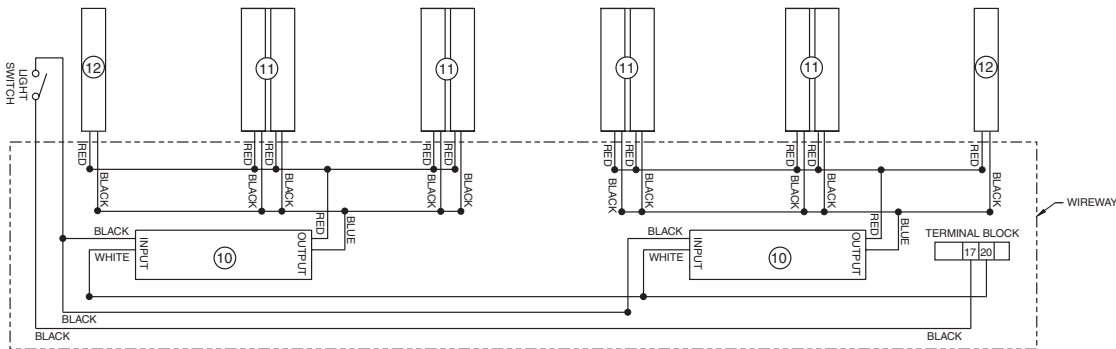

5 DOOR LED LIGHT WIRING DIAGRAM

**WARNING**

All components must have mechanical ground, and the merchandiser must be grounded.

CIRCLED NUMBERS = PARTS LIST ITEM NUMBERS

● = 120V POWER    ○ = 120V NEUTRAL    ⊥ = FIELD GROUND    ≡ = CASE GROUND

**Wiring Diagram is per side — two circuits required per case.**

**Wiring Diagram is per side — two circuits required per case.**

**LifeLine Premier RLNI**  
With INNOVATOR Doors  
Frozen Food & Ice Cream

CIRCLED NUMBERS = PARTS LIST ITEM NUMBERS  
R = Red P = Purple 2P = Purple (2 Bands)  
DB = Dark Blue B = Black  
BR = Brown Y = Yellow OR = Orange W = White  
**THESE ARE MARKER COLORS (WIRE MAY VARY.)**

**External Facade LED Wiring**

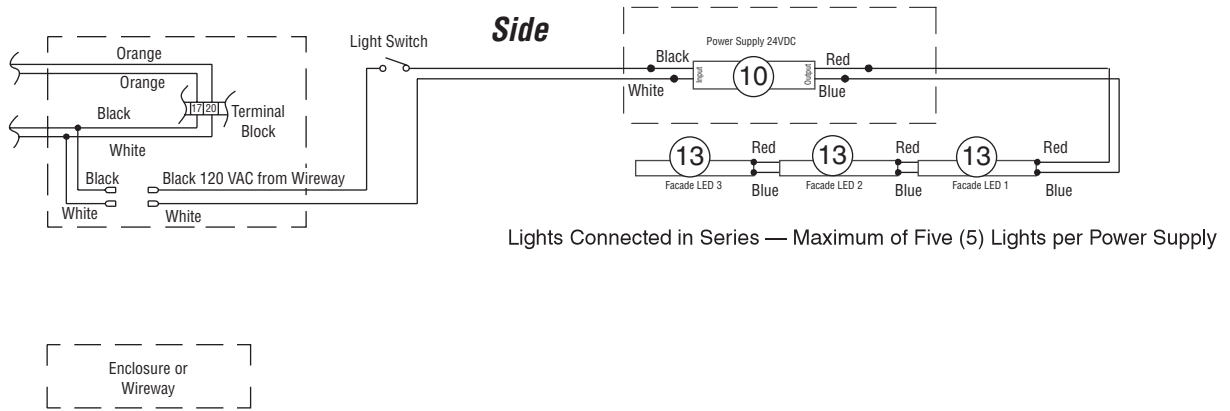

Lights Connected in Series — Maximum of Five (5) Lights per Power Supply

**WARNING**  
All components must have mechanical ground, and the merchandiser must be grounded.  
CIRCLED NUMBERS = PARTS LIST ITEM NUMBERS  
● = 120V POWER ○ = 120V NEUTRAL ⊥ = FIELD GROUND ≡ = CASE GROUND

**Wiring Diagram is per side — two circuits required per case.**