

We reserve the right to change or revise specifications and product design in connection with any feature of our products. Such changes do not entitle the buyer to corresponding changes, improvements, additions or replacements for equipment previously sold or shipped.

Item	Part #	Description	Wiring Item #	Item	Part #	Description	Wiring Item #
<b>FAN ASSEMBLIES AND THERMOSTATS</b>				<b>CONTROL PANEL</b>			
A.	<b>4W Standard Fan Assembly</b>		(1)	E.	0047449	Defrost Timer (TC.4480258)	(4)
	0392457	Fan Motor, Evaporator – 115V (MO.4410101)		F.	0019187	Disconnect Switch (SW.4440647)	(5)
	0376413	Fan Blade (FB.0376413)		G.	0513693	Pressure Control (CP.4482953)	(6)
	<b>4W Energy Efficient Fan Assembly</b>		(1)	H.	0515217	Power Cord (EP.4441769)	
	0477653	Fan Motor, Evaporator – 115V (MO.4410544)		<b>REFRIGERATION</b>			
	0376413	Fan Blade (FB.0376413)		I.	0512902	Condensing Unit Assembly 115V (EQ.4671458)	
B.	0510349	Standard Adjustable Refrigeration Thermostat (CT.4441543)	(2)	J.	0331344	Sight Glass (GL.4974431)	
<b>HEATERS</b>				K.	0111482	Drier (FI.4611727)	
C.	0314573	Condensate Pan Heater 120V (HE.0314573)	(3)	L.	0515380	Crankcase Pressure Regulator (VR.4613797)	
D.	11584P	Condensate Pan (DP.4982972)		M.	TEV		
					0515366	6 ft (VR.4613794)	
					0515333	8 ft (VR.4613793)	
				<b>LAMPS AND BALLASTS (IN OPTIONAL LIGHTING)</b>			
				N.	Ballast, Electronic		(7)
					0466234	2 lamps (BA.4480823)	
					0466235	3 lamps (BA.4480901)	
				O.	Fluorescent Lamp		(8)
						Replace with like fixtures	

Note: Revision A is original issue



# Engineering Plan Views

## M1-GEB

Meat / Delicatessen  
Precut & Packaged Produce,  
Self-Contained

Dimensions shown as inches and (mm).

03-10

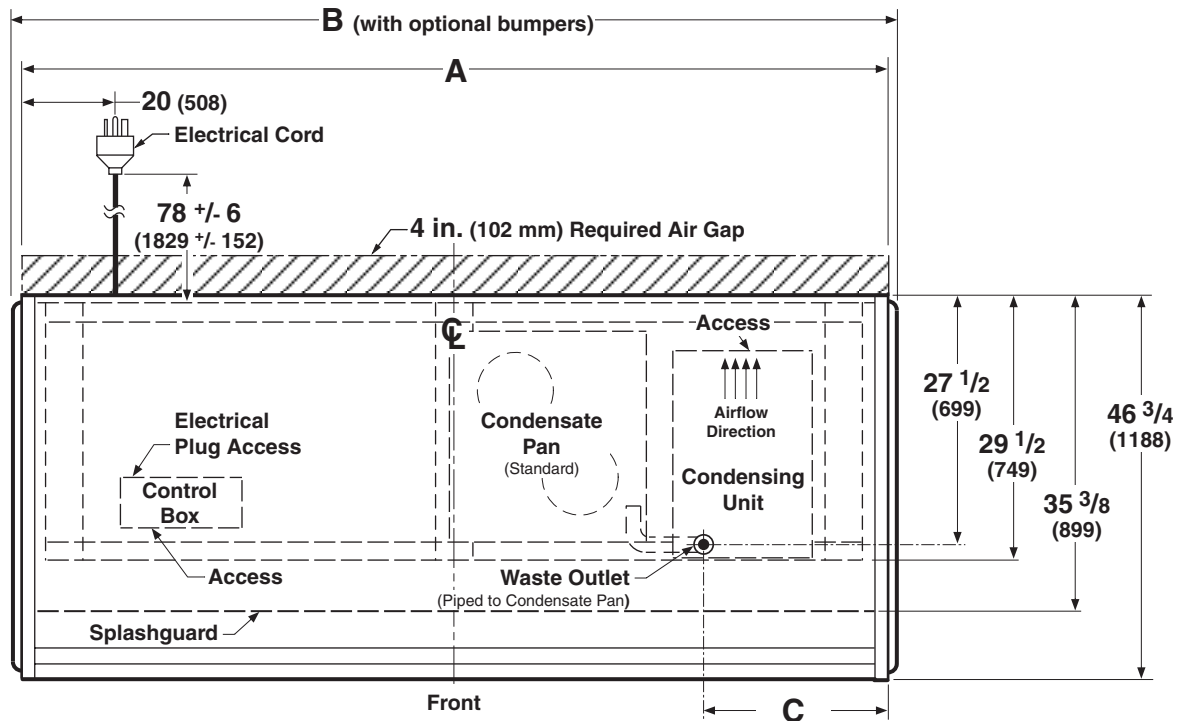

	6 ft	8 ft
<b>General</b>		
<b>A</b> Case Length <i>(Note: Includes One Pair Ends)</i>	75 3/8 (1915)	99 3/8 (2524)
<b>B</b> Optional End Bumpers <i>(One Pair)</i>	2 (51)	2 (51)
Maximum O/S dimension of case back to front <i>(Note: Includes bumper)</i>	46 3/4 (1188)	46 3/4 (1188)
Back of case to front of splashguard	35 3/8 (899)	35 3/8 (899)
Width of skid rail	4 1/4 (108)	4 1/4 (108)
RH end of case of outside edge of external support	2 3/4 (70)	2 3/4 (70)
Width of external and center supports	4 1/4 (108)	4 1/4 (108)
Distance between edges of external supports and center support	28 1/2 (724)	40 1/2 (1029)
<b>Waste Outlet</b> ●		
<b>C</b> RH end of case <i>(from outside of End Assembly)</i> to center of waste outlet	25 1/2 (648)	25 3/4 (654)
Back of case to center of waste outlet	27 1/2 (699)	27 1/2 (699)

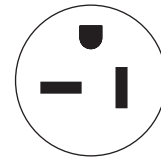

**PLUG**  
NEMA 5-20P  
20A 125V  
UL/CSA

Single Deck, Glass Front, 1 Display Level, Self-Contained

**Impact M1-GEB**  
**Meat / Delicatessen**  
**Precut & Packaged Produce,**  
**Self-Contained**

Dimensions shown as inches and (mm).

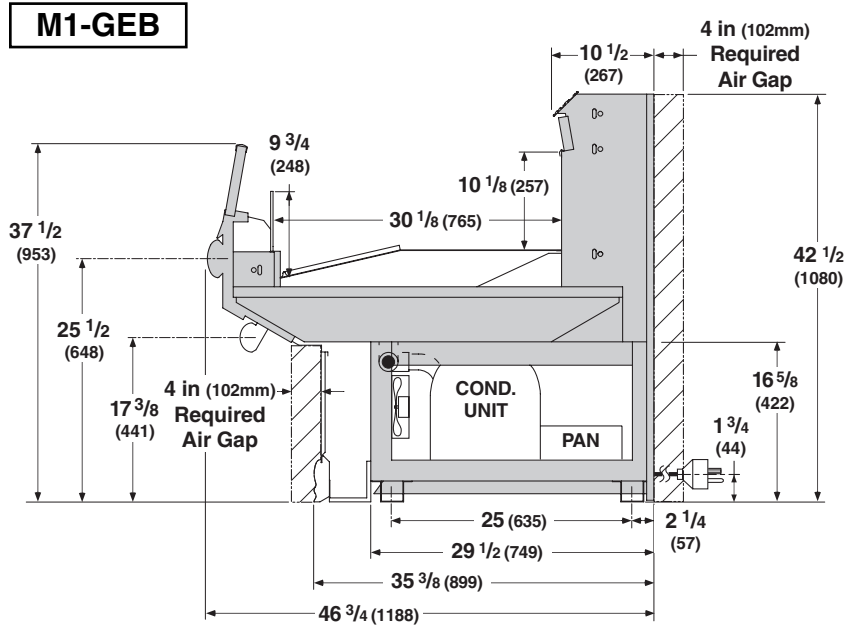

**REFRIGERATION DATA**

**Note:** This data is based on store temperature and humidity that does not exceed 75°F and 55% R.H. unless otherwise stated. Schedule defrost at night while lights are off.

	<b>M1-GEB</b>
<b>Thermostat Setting CI/CO (°F)</b>	26 / 22
<b>Condensing Unit (hp)</b>	0.50
<b>Condensing Unit Capacity (Btu/hr at std. rating conditions)</b>	4010

**DEFROST DATA**

	<b>M1-GEB</b>
<b>Frequency (hr)</b>	6
<i>OFFTIME</i>	
<b>Failsafe (minutes)</b>	35
<b>Defrost Termination Pressure (psig)</b>	100 (48°F)

**CONVENTIONAL CONTROLS**

<b>Low Pressure Backup Control</b>	<b>M1-GEB</b> <b>CI/CO</b>
<b>HPC (psig)</b>	400/450
<b>LPC (psig)</b>	45/34

**PHYSICAL DATA**

			<b>M1-GEB</b>
<b>Refrigerant Charge</b>			
6 ft	3.0 lb	48 oz	1.4 kg
8 ft	3.0 lb	48 oz	1.4 kg

**NSF® Certification**

This merchandiser model is manufactured to meet ANSI/NSF® (National Sanitation Foundation) Standard #7 requirements for construction, materials & cleanliness.

<b>Impact M1-GEB</b> <b>Meat / Delicatessen</b> <b>Precut &amp; Packaged Produce,</b> <b>Self-Contained</b>
--

### Electrical Data

*Note: These are rated values for individual components and should not be added together to determine total merchandiser electrical load.*

	<b>6ft</b>	<b>8 ft</b>		
<b>Number of Fans – 4W</b>	<b>2</b>	<b>2</b>		
	<b>Amperes</b>		<b>Watts</b>	
	<b>6 ft</b>	<b>8 ft</b>	<b>6 ft</b>	<b>8 ft</b>
<b>Evaporator Fans</b>				
120V 60Hz Standard	0.62	0.62	48	48
120V 60Hz Energy Efficient	0.24	0.24	16	16
<b>Condensate Pan Heaters (120V)</b>	8.34	8.34	1000	1000
<b>Condensing Unit (120V, 1Ph, 60Hz)</b>				
Minimum Circuit Ampacity	12.3	12.3		
Compressor LRA	33.6	33.6		
Compressor RLA	9.2	9.2		
<b>Lighting</b>				
<b>Standard</b>	<b>6 ft</b>	<b>8 ft</b>	<b>6 ft</b>	<b>8 ft</b>
None	NA	NA	NA	NA
<b>Optional Lighting (T-8 Fluorescent)</b>				
1 Row Light Bar	0.50	0.50	60	60
1 Row Rail	0.50	0.50	60	60
1 Row Ledge	0.50	0.50	60	60
<b>Circuit Amp Rating at Plug</b>				
120V 1Ph 60Hz Standard	13.9	13.9		
120V 1Ph 60Hz Energy Efficient	13.5	13.5		
Add for Optional Lighting	0.50 per row	0.50 per row		
<b>Maximum Over Circuit Protection 120V</b>	<b>20</b>	<b>20</b>		

**Product Data**

**M16GEB**

<i>Recommended Usable Cube</i> <sup>1</sup> (Cu Ft/Case)	9.12 ft <sup>3</sup> /case (0.26 m <sup>3</sup> /case)
<i>AHRI Total Display Area</i> <sup>2</sup> (Sq Ft/Case)	15.71 ft <sup>2</sup> /case (1.46 m <sup>2</sup> /case)
<i>Shelf Area</i> <sup>3</sup> (Sq Ft/Case)	15.06 ft <sup>2</sup> /case (1.40 m <sup>2</sup> /case)

**M18GEB**

<i>Recommended Usable Cube</i> <sup>1</sup> (Cu Ft/Case)	12.16 ft <sup>3</sup> /case (0.34 m <sup>3</sup> /case)
<i>AHRI Total Display Area</i> <sup>2</sup> (Sq Ft/Case)	20.94 ft <sup>2</sup> /case (1.95 m <sup>2</sup> /case)
<i>Shelf Area</i> <sup>3</sup> (Sq Ft/Case)	20.08 ft <sup>2</sup> /case (1.87 m <sup>2</sup> /case)

<sup>1</sup> AHRI Refrigerated Volume less shelving and other unusable space: Refrigerated Volume / Unit of Length, ft<sup>3</sup>/ft [m<sup>3</sup>/m]  
<sup>2</sup> Computed using AHRI 1200 standard methodology: Total Display Area, ft<sup>2</sup> [m<sup>2</sup>] / Unit of Length, ft [m]  
<sup>3</sup> Shelf surface area is composed of bottom deck plus standard shelf complement, as shown in the Hussmann *Product Reference Guide*. The standard shelf complement for this model is NONE.

<b>ESTIMATED SHIPPING WEIGHT <sup>4</sup></b>			
<b>Case</b>	<i>6 ft</i>	<i>8 ft</i>	<i>End</i>
<b>lb (kg)</b>	660 ( 299 )	860 ( 390 )	Included
<sup>4</sup> Actual weights will vary according to optional kits included.			

**Impact M1-GEB**  
**Meat / Delicatessen**  
**Precut & Packaged Produce,**  
**Self-Contained**

**Electrical Wiring**

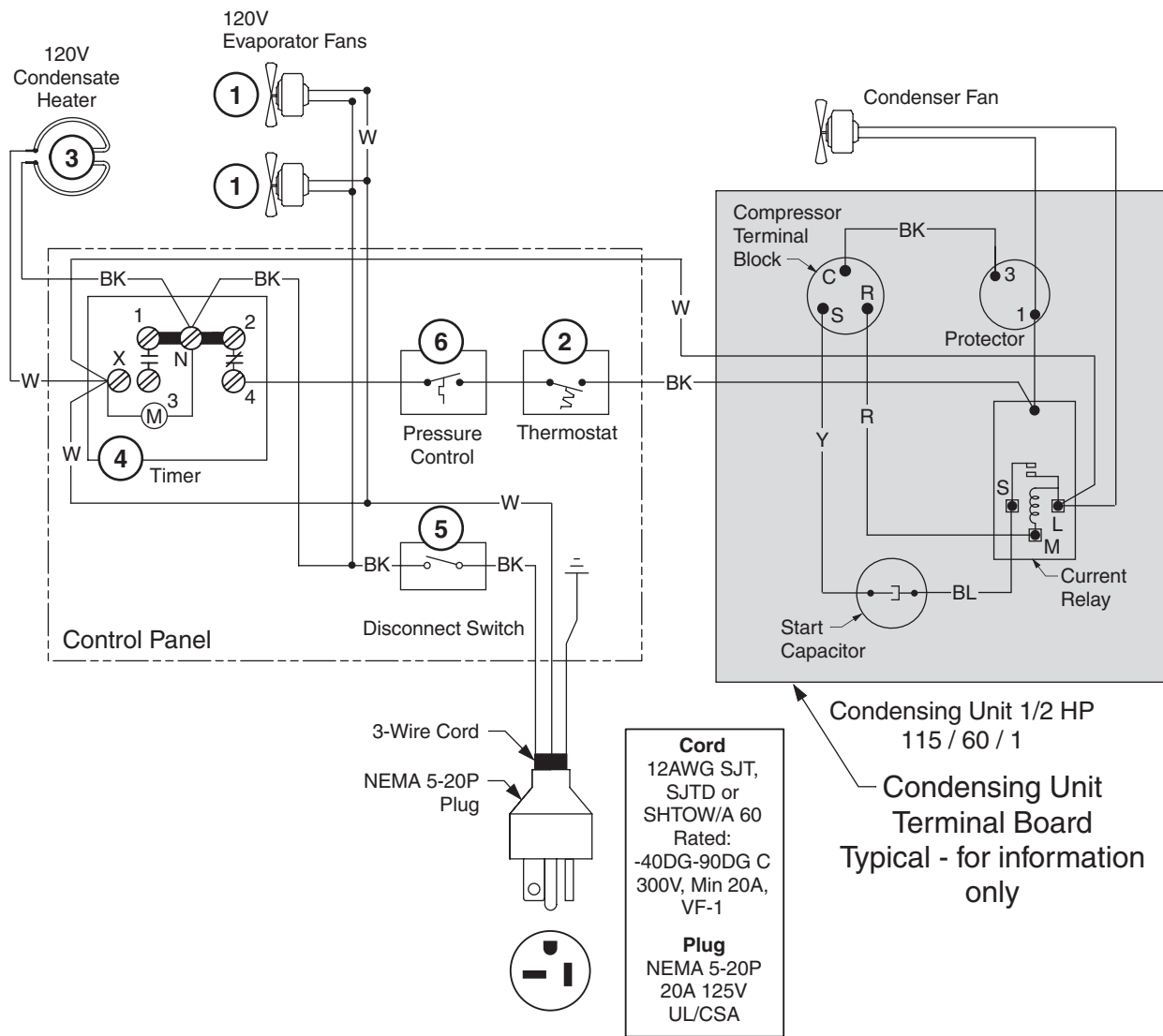

**WARNING**

All components must have mechanical ground, and the merchandiser must be grounded.

CIRCLED NUMBERS = PARTS LIST ITEM NUMBERS

R = Red Y = Yellow G = Green BL = Blue BK = Black W = White

● = 120V POWER    ○ = 120V NEUTRAL    ⊥ = FIELD GROUND    ≡ = CASE GROUND

# Light Circuits

Impact **M1-GEB**  
Meat / Delicatessen  
Prect & Packaged Produce,  
Self-Contained

## Optional Lighting — 1 Row Light Bar

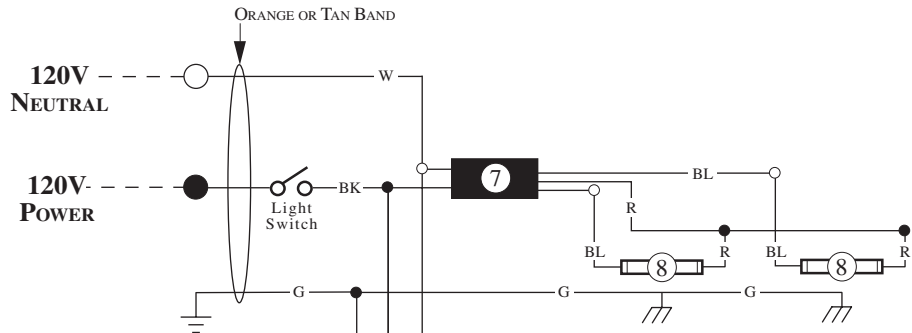

## Optional Rail Light Circuit

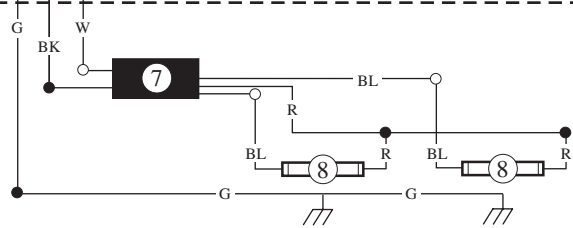

## Typical Shelf Ballast Wiring

Maximum lamps per ballast is three (3).  
Different shelf configurations and different case lengths will have more shelf ballasts.

## Optional Ledge Light Circuit

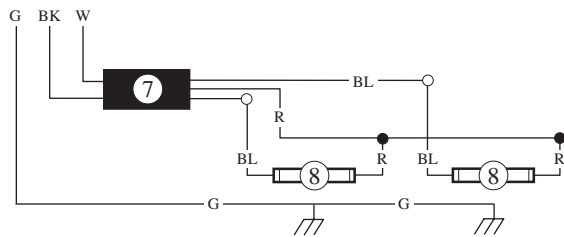

### WARNING

All components must have mechanical ground, and the merchandiser must be grounded.

CIRCLED NUMBERS = PARTS LIST ITEM NUMBERS

R = Red Y = Yellow G = Green BL = Blue BK = Black W = White

● = 120V POWER    ○ = 120V NEUTRAL    ⊥ = FIELD GROUND    ≡ = CASE GROUND