

HUSSmann®



DDSS-4MC

***Medium Temperature Self Contained
Open Vertical Merchandisers***



DDSS-4MC

Installation & Operation Manual

IMPORTANT
Keep in store
for future reference!

P/N 0515957_G
February 2015

MANUAL - I/O SELF CONTAINED DDSS-4MC

Spanish 0531283
French 0531284

ATTENTION

Merchandiser must operate for 24 hours
before loading product!

Regularly check merchandiser temperatures.

Do not break the cold chain. Keep products
in cooler before loading into merchandiser.

These merchandisers are designed
for pre-chilled products only.



IMPORTANT
KEEP IN STORE FOR FUTURE REFERENCE
Quality that sets industry standards!

12999 St. Charles Rock Road • Bridgeton, MO 63044-2483

U.S. & Canada 1-800-922-1919 • Mexico 01 800-890-2900

www.hussmann.com

© 2015 Hussmann Corporation

TABLE OF CONTENTS

BEFORE LOADING PRODUCT iii
ANSI DEFINITIONS vi

INSTALLATION

Certification 1-1
Husmann Product Control 1-1
Shipping Damage 1-1
Location 1-1
Self Contained (Location) 1-2
Model Description 1-3
Unloading 1-3
Exterior Loading 1-3
Shipping Skid 1-3
Merchandiser Leveling 1-4
Serial Plate Location 1-4
Refrigeration Unit Access 1-4
Casters 1-4
Sealing Merchandiser to Floor 1-4

ELECTRICAL / REFRIGERATION

Merchandiser Electrical Data 2-1
Field Wiring 2-1
Electrical Connections 2-1
Electrical Outlet 2-1
Refrigeration (Self Contained). 2-1
Water Outlet and Water Seal 2-2

START UP / OPERATION

Safe-NET III™ User Instructions 3-1
Display 3-2
Start-Up 3-2
Sequence of Operation Diagram 3-3
Temperature Adjustment 3-4
Alarms and Codes 3-4
Defrost Termination Switch 3-4
Manual Defrost 3-4
Temperature Adjustment 3-5
Sensor Location 3-6

Controls and Adjustments 3-7
Thermostatic Expansion Valve 3-8
TEV Adjustment 3-8
Load Limits 3-9
Stocking 3-9
Thermometer 3-9
Notes 3-10

MAINTENANCE

Care and Cleaning 4-1
Do NOT Use: 4-1
Do: 4-1
Removing Scratches from Bumper 4-2
Cleaning Under Fan Plenum 4-2
Cleaning Stainless Steel Surfaces 4-2
Cleaning Discharge Honeycomb 4-3
Cleaning Coils 4-3
Cleaning Evaporation Pan 4-4

SERVICE

Replacing Fan Motors and Blades 5-1
Replacing Electronic Ballasts or
LED Power Supplies 5-2
Replacing Fluorescent or LED Fixtures 5-2
Repairing Aluminum Coil 5-2
Replacing Electronic Ballasts 5-2

APPENDIX

Part Numbers A-1
Plan View DDSS-4MC A-3
Cross Sections and Refrigeration Data A-4
Electrical Data A-5
Self Contained Wiring Diagram A-6

WARRANTY

REVISION HISTORY

REVISION G — Sensor Location, 3-6; Updated Coil photos, 3-8, parts list A-1, A-2 new Wiring Diagram, A-5 Replacing Fluorscent Lamps and Ballasts, 5-2

REVISION F — Added Checklists Page 1-7 and 1-8; Added Warning Page 1-3; Cleaning Coils 4-3; Maintaining Fluorescent Lights 4-4.

REVISION E — FEBRUARY 2012

- 1. Updated Wiring Diagrams
- 2. Updated Mexico phone number

REVISION D — JANUARY 2012

- 1. Removed DDSS-4 Model
- 2. Added new part numbers
- 3. Revised refrigeration data
- 4. Added LED replacement, Page 5-2

REVISION C — MAY 2011

- 1. Revised Cross Section Shelf Length, page A-4

REVISION B — OCTOBER 2010

- 1. Added self contained location drawings, page 1-2
- 2. Added Remote Line Sizing, Koolgas, page 2-2
- 3. Added Koolgas and Remote Refrigeration, page 2-9
- 4. Added TEV drawing and adjustment, page 3-8
- 5. Added Cleaning Precautions, page 4-4
- 6. Added dimension drawings & technical data, pages, A-1, A-2

ORIGINAL ISSUE — MARCH 2010

ANSI Z535.5 DEFINITIONS



• **DANGER** – Indicate[s] a hazardous situation which, if not avoided, will result in death or serious injury.



• **WARNING** – Indicate[s] a hazardous situation which, if not avoided, could result in death or serious injury.



• **CAUTION** – Indicate[s] a hazardous situation which, if not avoided, could result in minor or moderate injury.

• **NOTICE** – *Not related to personal injury* – Indicates[s] situations, which if not avoided, could result in damage to equipment.

INSTALLATION

CERTIFICATION

These merchandisers are manufactured to meet ANSI / National Sanitation Foundation (NSF®) Standard #7 requirements. Proper installation is required to maintain certification. Near the serial plate, each case carries a label identifying the type of application for which the case was certified.

ANSI/NSF-7 Type I - Display Refrigerator / Freezer

Intended for 75°F / 55% RH Ambient Application

ANSI/NSF-7 Type II - Display Refrigerator / Freezer

Intended for 80°F / 55% RH Ambient Application

ANSI/NSF-7 - Display Refrigerator

Intended for Bulk Produce

HUSSMANN PRODUCT CONTROL

The serial number and shipping date of all equipment is recorded in Hussmann's files for warranty and replacement part purposes. All correspondence pertaining to warranty or parts ordering must include the serial number of each piece of equipment involved. This is to ensure the customer is provided with the correct parts.

SHIPPING DAMAGE

All equipment should be thoroughly examined for shipping damage before and during unloading. This equipment has been carefully inspected at our factory. Any claim for loss or damage must be made to the carrier. The carrier will provide any necessary inspection reports and/or claim forms.

Apparent Loss or Damage

If there is an obvious loss or damage, it must be noted on the freight bill or express receipt and signed by the carrier's agent; otherwise, carrier may refuse claim.

Concealed Loss or Damage

When loss or damage is not apparent until after equipment is uncrated, retain all packing materials and submit a written response to the carrier for inspection within 15 days.

LOCATION

These merchandisers are designed for displaying products in air conditioned stores where temperature is maintained at or below the ANSI / NSF-7 specified level and relative humidity is maintained at or below 55%.

Recommended operating ambient temperature is between 65°F (18°C) to 80°F (26.7°C). Maximum relative humidity is 55%.

Placing refrigerated merchandisers in direct sunlight, near hot tables or near other heat sources could impair their efficiency. Like other merchandisers, these merchandisers are sensitive to air disturbances. Air currents passing around merchandisers will seriously impair their operation. Do NOT allow air conditioning, electric fans, open doors or windows, etc. to create air currents around the merchandiser.

1-2 INSTALLATION

Product should always be maintained at proper temperature. This means that from the time the product is received, through storage, preparation and display, the temperature of the product must be controlled to maximize the life of the product.

BE SURE TO POSITION SELF CONTAINED MERCHANDISERS PROPERLY.

SELF CONTAINED models have vented base panels to allow air circulation through the condensing unit. Allow for a minimum 4 in. clearance from walls, merchandisers, and any other large objects near the merchandiser's vented base panels (for self contained models). Blocking or restricting air flow will adversely affect performance and may damage the refrigeration system.

For California Businesses:

! WARNING

This product may contain chemicals known to the State of California to cause cancer, birth defects, or other reproductive harm.

This warning is the result of the California State law known as the California Safe Drinking Water and Toxic Enforcement Act of 1986, which is commonly referred to as "Proposition 65."

This warning does not mean that Hussmann products will cause cancer or reproductive harm, or is in violation of any product-safety standards or requirements. As clarified by the California State government, Proposition 65 can be considered more of a 'right to know' law than a pure product safety law. When used as designed, Hussmann believes that our products are not harmful. We provide the Proposition 65 warning to stay in compliance with California State law. It is your responsibility to provide accurate Proposition 65 warning labels to your customers when necessary. For more information on Proposition 65, please visit the California State government website.

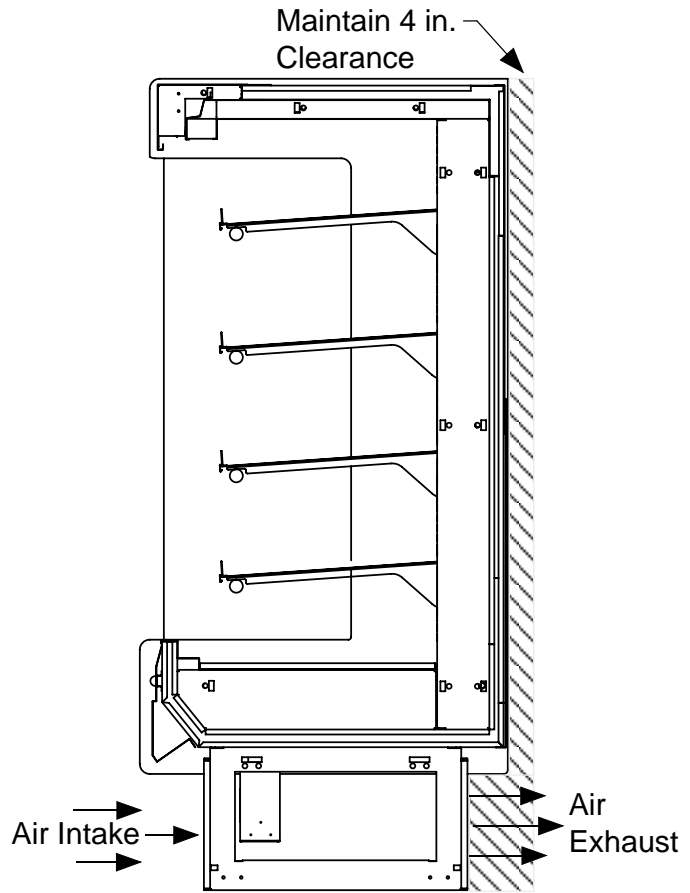

Keep discharge and intake areas free from air currents.

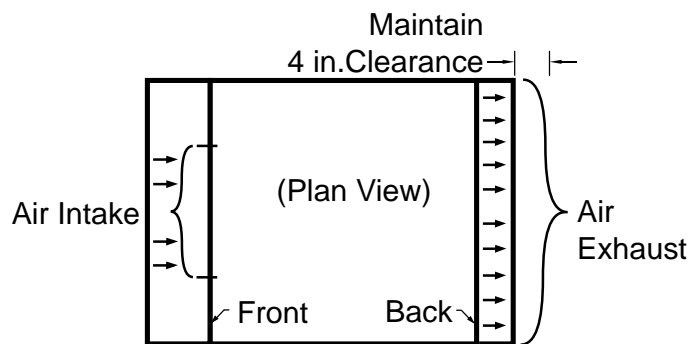

MODEL DESCRIPTION

The DDSS models are open, vertical, medium temperature display merchandisers. Each self contained model will have its own condensing unit, factory installed beneath the display area of the case ready for operation when electrical service is connected.

UNLOADING

Unloading from Trailer:

Lever Bar (also known as a Mule, Johnson Bar, J-bar, Lever Dolly, or Pry Lever)

Move the merchandiser as close as possible to its permanent location and remove all packaging. Check for damage before discarding packaging. Remove all separately packed accessories such as kits and shelves.

Improper handling may cause damage to the merchandiser when unloading. To avoid damage:

1. Do not drag the merchandiser out of the trailer. Use a Johnson bar (mule).
2. Use a forklift or dolly to remove the merchandiser from the trailer.

WARNING

Do NOT stand or walk on top of merchandiser. Do not store items or flammable materials atop the unit.

EXTERIOR LOADING

Do NOT walk on top of merchandisers or damage to the merchandisers and serious personal injury could occur.

MERCHANDISERS ARE NOT STRUCTURALLY DESIGNED TO SUPPORT EXCESSIVE EXTERNAL LOADING such as the weight of a person. Do not place heavy objects on the merchandiser.

SHIPPING SKID

Each merchandiser is shipped on a skid to protect the merchandiser's base, and to make positioning the case easier.

Remove the top of the crate and detach walls from each other. Lift crate from the skid. Unscrew the case from the skid. The fixture can now be lifted off the crate skid. **Lift only at base of skid!** Remove any braces and/or skids attached (blanket wrapped merchandiser may have skids).

DO NOT LAY MERCHANDISER OVER ON THE FLOOR TO REMOVE SKID.

Once the skid is removed, the merchandiser must be lifted —NOT PUSHED— to reposition. To remove the skid, remove screws attaching skid to the merchandiser.

Check floor where cases are to be set to see if it is a level area. Determine the highest part of the floor.

WARNING

Do NOT remove shipping crate until the merchandiser is positioned for installation.

1-4 INSTALLATION

MERCHANDISER LEVELING

BE SURE TO POSITION MERCHANDISERS PROPERLY. Level the merchandiser by all four corners. Merchandiser(s) must be installed level to ensure proper operation of the refrigeration system, and to ensure proper drainage of defrost water.

SERIAL PLATE LOCATION

The serial plate is located at the interior top left end. It contains all pertinent information such as model, serial number, amperage rating, refrigerant type and charge.



REFRIGERATION UNIT ACCESS

The lower front panel may be removed by lifting the panel straight upward and over the tabs on which it is hanging. In a self contained merchandiser, two screws will have to be removed from either end of the panel. The panel is installed by reversing the above procedure. Ensure lower front panel is flat against the floor when installed to prevent air circulation problems on self contained merchandisers.

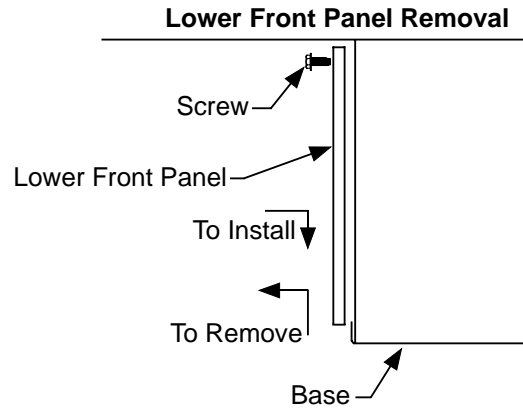

CASTERS

The merchandiser is equipped with optional casters. Use the brake to lock the merchandiser in place.

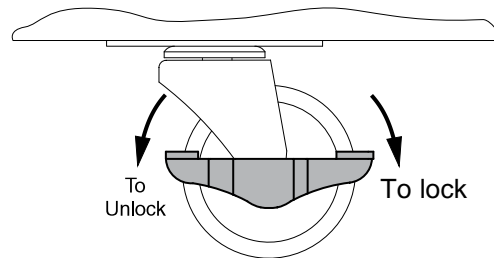

SEALING MERCHANDISER TO FLOOR

If required by local sanitary codes, or if the customer desires, merchandisers may be sealed to the floor using a vinyl cove base trim. The size needed will depend on how much variation there is in the floor, from one end of the merchandiser to the other. Sealing of the lower front and rear panels on self contained models may hamper their removal for servicing or maintenance of the condensing unit.

NOTE: Do not allow trim to cover any intake or discharge grilles located in the lower front panel.

Hussmann Self-Contained Refrigeration Equipment Start Up Check List

Please note that failure to follow this start-up document may void your factory warranty

Step	Startup Activity	Check
1	Locate, read and maintain install/operation manual in a safe place for future reference.	<input type="checkbox"/>
2	Examine unit. Confirm there is NO damage or concealed damage.	<input type="checkbox"/>
3	Level the unit, side to side and front to rear.	<input type="checkbox"/>
4	Remove all shipping brackets/compressor straps/bolts etc.	<input type="checkbox"/>
5	Unit must be run on a dedicated electrical circuit without the use of an extension cord.	<input type="checkbox"/>
6	Ensure that the proper electrical requirements for the equipment are supplied.	<input type="checkbox"/>
7	Verify field electrical connections are tight.	<input type="checkbox"/>
8	Verify all electrical wiring is secured and clear of any sharp edges or hot lines.	<input type="checkbox"/>
9	Verify the condensate drain line is properly trapped and pitched.	<input type="checkbox"/>
10	Verify all required clearances on the sides and back of unit.	<input type="checkbox"/>
11	Verify there are no air disturbances external to the unit. Heat and air registers, fans, and doors etc.	<input type="checkbox"/>
Advise owner/operator that merchandiser must operate at temperature for 24 hrs prior to loading with product.		

Form HSCW01 Rev. 30MAY12 P/N 0525209_B

LEGAL DISCLAIMER:

Hussmann shall not be liable for any repair or replacements made without the written consent of Hussmann, or when the product is installed or operated in a manner contrary to the printed instructions covering installation and service which accompanied such product.

Hussmann Self-Contained Refrigeration Equipment Start Up Check List

Hussmann Corporation, 12999 St Charles Rock Road, Bridgeton, MO 63044-2483 U.S.A.
 Email: hussmannwarrantyregistration@hussmann.com Fax: 866-443-1254

Today's Date	
Store Name and Number	
Store Address	
Unit Model Number	
Unit Serial Number	
Contractor/Technician	
Startup activity	Record date of completion or requested data (i.e., voltage, measurements, instrument readings).
Locate, read and maintain install/operation manual in a safe place for future reference.	
Examine unit. Confirm there is NO damage or concealed damage.	
Level the unit, side to side and front to rear.	
Remove all shipping brackets/compressor straps/bolts etc.	
Unit must be run on a dedicated electrical circuit without the use of an extension cord.	
Record supply voltage at outlet with unit off.	Volts -
Verify refrigerant lines are properly secured and not touching or rubbing other lines, wires or frame work.	
Verify fan motors and motor mounts are tight.	
Verify fan blade/s are tight and are not rubbing/contacting other components.	
Verify field and factory electrical connections are tight.	
Verify electrical connections at lamps are tight and secure.	
Verify all electrical wiring is secured and clear of any sharp edges or hot lines.	
Verify there any no visible oil or refrigerant leaks.	
Verify the condensate drain line is properly trapped and pitched.	
What are the clearances on the sides and back of unit?	Left Side - Right Side - Back - Top -
Are there any air disturbances external to the unit? Heat and air registers, fans, and doors etc.	
Start up unit, record total unit amp draw after 5 minutes of operation.	Total unit amps -
Record compressor amp draw.	Amps -
Record anti-sweat heater amp draw if applicable	Amps - N/A
Record voltage reading with unit running.	Volts -
Verify condenser and evaporator fans are working	
Is condenser air inlet or air exhaust restricted or recirculating?	
Record ambient conditions around unit (wet Bulb temperature and dry bulb temperature) and RH%	Wet Bulb °F Dry Bulb °F RH%
Record condenser air inlet temp (center of the coil)	°F
Record condenser air outlet temp (right after the fan motor)	°F
After unit reaches operating temperature, record unit discharge air temperature (center of the flue).	°F
After unit reaches operating temperature, record unit return air temperature (center of flue).	°F
Does unit controller operate properly? See controller or I/O manual for proper controller operation.	
Record defrost heater amp draw (when applicable).	Amps -
Verify there are no visible water leaks.	
Verify door switches work correctly, turning evap fans on and off.	
Verify unit doors and lids work and are fully sealed.	
Verify that all the panels, shields and covers are in place.	
Confirm the unit has no vibrations or abnormal noise.	
Advise owner/operator that merchandiser must operate at temperature for 24 hrs prior to loading with product.	

Technician Notes:

LEGAL DISCLAIMER:

Hussmann shall not be liable for any repair or replacements made without the written consent of Hussmann, or when the product is installed or operated in a manner contrary to the printed instructions covering installation and service which accompanied such product.

ELECTRICAL / REFRIGERATION

MERCHANDISER ELECTRICAL DATA

Refer to merchandiser serial plate for electrical information.

FIELD WIRING

Field wiring must be sized for component amperes stamped on the serial plate. Actual ampere draw may be less than specified.

ALWAYS CHECK THE SERIAL PLATE FOR COMPONENT AMPERES

ELECTRICAL CONNECTIONS

All wiring must be in compliance with NEC and local codes. All electrical connections (*for remote models*) are to be made in the electrical *Handy Box* located behind the removable base panel at the left end of the merchandiser when facing the discharge honeycomb.

ELECTRICAL OUTLET:

Before the merchandiser is connected to any wall circuit, use a voltmeter to check that the outlet is at 100% of the rated voltage. The wall circuit must be dedicated for the merchandiser. Failure to do so voids the warranty. **Do not use an extension cord.** Never plug in more than one merchandiser per electrical circuit.

- Always use a dedicated circuit with the amperage stated on the unit.
- Plug into an outlet designed for the plug.
- Do not overload the circuit
- Do not use long or thin extension cords. Never use adapters.
- If in doubt, call an electrician.



WARNING

— LOCK OUT / TAG OUT —

To avoid serious injury or death from electrical shock, always disconnect the electrical power at the main disconnect when servicing or replacing any electrical component. This includes, but is not limited to, such items as doors, lights, fans, heaters, and thermostats.

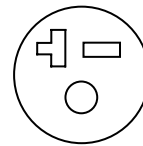

NEMA 6-20R
Receptable
DDSS-4MC

Self-contained models have factory-installed power cords attached at the electrical box.

REFRIGERATION (Self Contained Models)

Each self contained model is equipped with its own condensing unit and control panel located beneath the display area. The correct type of refrigerant will be stamped on each merchandiser's serial plate. The merchandiser refrigeration piping is leak tested. The unit is charged with refrigerant, and shipped from the factory with all service valves open.



CAUTION

Risk of Electric Shock. If cord or plug becomes damaged, replace only with a cord and plug of the same type.



WARNING

**Merchandiser must be grounded.
Do not remove the power supply cord ground.**

WATER OUTLET AND WATER SEAL

The condensate water outlet is located in the center of the merchandiser. The outlet has an external water seal installed from the factory.

This water seal drains into the condensate evaporation pan located beneath the merchandiser. Remote models have a fan to circulate air around the base to keep condensation from forming.

NOTE: All lower base panels must be in place when the refrigerator is operating. If not, airflow from the condenser (self-contained) will be directed over the evaporation pan and defrost water in the pan may overflow.

**CAUTION**

When brazing pipes, be sure to use the insulation blanket shipped with the merchandiser to prevent damage to the metal merchandiser bottom.

**WARNING**

Refrigeration lines are under pressure.
Refrigerant must be recovered before
attempting any connection or repair.

**WARNING**

Product will be degraded and may spoil if
allowed to sit in a non-refrigerated area.

START UP / OPERATION



**...ATTENTION
INSTALLER**

It is the contractor's responsibility to install merchandiser(s) in accordance with all local building and health codes.

Safe-NET III™ TEMPERATURE AND DEFROST CONTROLLER

SAFE-NET III™ USER INSTRUCTIONS

Your refrigerated case uses a Hussmann Safe-NET™ III temperature and defrost controller to precisely maintain the temperature and prevent frost buildup on the cooling coil. LEDs indicate when the compressor or refrigeration is on, when the case is in a defrost cycle, if the temperature is outside the desired range, or if there is a sensor failure.

An adjustment knob allows the temperature to be set within the configured range and can power off the controller and compressor. Your controller has been custom-configured to provide the best temperature and defrost control for your chilled or frozen food.

The front of the controller has an adjustment knob and status LEDs. The back of the controller has connections for sensors and switched equipment.

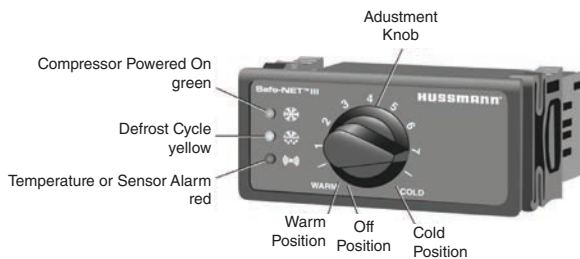

The Safe-NET III controller includes the following features and connections.

- Adjustment knob:
Adjusts the temperature setpoint.
Turn adjustment knob to OFF to turn off refrigeration system. Unplug merchandiser from power before servicing the unit.

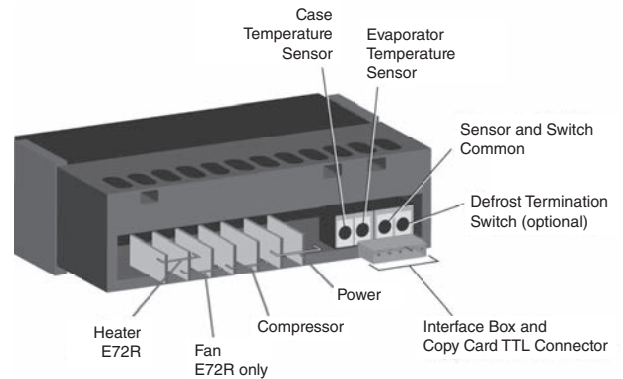

- Controller LEDs:
 - Compressor Powered On LED (green):
 - ❄ Lights while the compressor is running or the refrigeration valve is open.
 - Defrost Cycle LED (yellow):
 - ❄ Lights while the refrigeration coil is defrosting.
 - Temperature or Sensor Alarm (red):
 - 🔊 Lights if the temperature is too warm or too cold. Flashes if a sensor fails.

- Rear connections:
 - Case temperature sensor:
 - Typically senses the temperature of the air in the case.
Used by the controller to determine when to power on or power off the compressor or refrigeration.
 - Evaporator temperature sensor:
 - Senses the temperature of the refrigeration coil.
Terminates a defrost cycle when refrigeration coil ice melts.
 - Compressor or refrigeration relay:
 - Switches on the compressor or refrigeration valve for cooling.

! WARNING

The optional evaporator fan remains ON when the adjustment knob is in the OFF position.

DISPLAY

The display includes three red LEDs and two digits for temperature, defrost status, and error codes.

The three display LEDs are red, and their behavior matches the LEDs on the controller.



START-UP

1. Plug in the merchandiser.

! WARNING

The OFF Position does not disconnect line voltage to the case, refrigeration unit, fan, or heater.

NOTE: The 65°C Version Controller includes a Parameter Code Number. This number indicates what program has been loaded into the controller. When the Controller is first powered up or is turned off and then back on a 2 digit Parameter Code Number will display for 3 seconds. Then the Self Check will Start.

2. Wait for the self check to complete. During the self check, each LED flashes for one second, then all LEDs turn on for two seconds. If the LEDs do not flash, make sure the adjustment knob is not in the Off position.
 - After the self check, all LEDs turn off until the compressor starts. **There may be a delay before the compressor starts.** If the red Temperature or Sensor Alarm LED stays on after the self check.
 - The green Compressor Powered On LED turns on when the compressor starts. **Parameter Code is 54.**

NOTE: Do NOT load product until AFTER merchandiser operates for 24 hours and reaches desired operating temperature.

! WARNING

Product will be degraded and may spoil if allowed to sit in a non-refrigerated area.

SEQUENCE OF OPERATION
DDSS-4MC

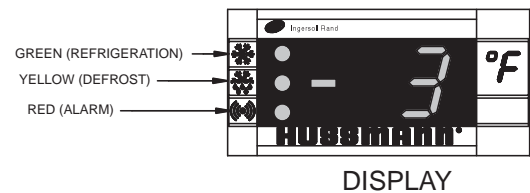
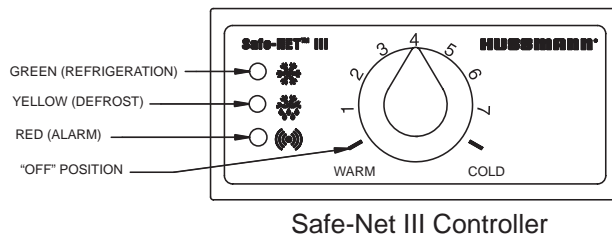
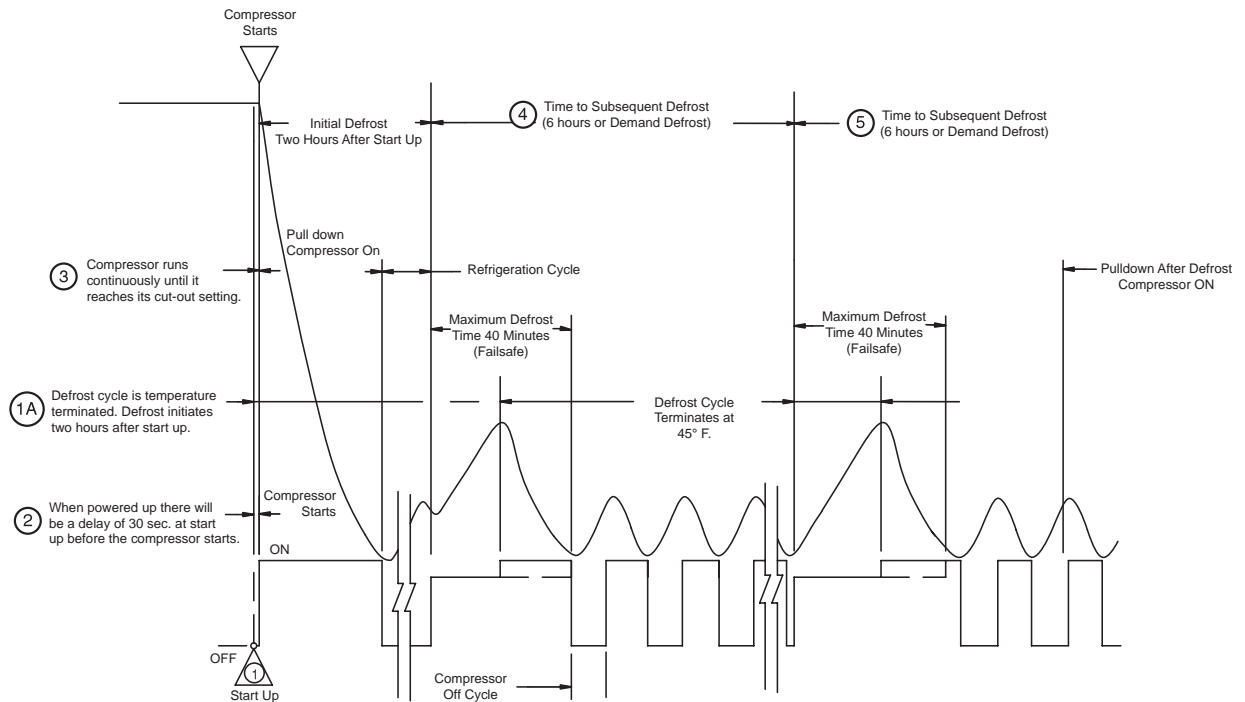

1. Apply power to the merchandiser. Wait for the self check to complete. During the self check, each LED flashes for one second and then all LEDs turn on for two seconds. If the LEDs do not flash, make sure the adjustment knob is not in the “OFF” position.
- 1A. The merchandiser temperature displays at startup. The initial defrost starts two hours later. The display will show the temperature at the start of defrost. This reading will remain displayed during defrost and until it times out, even though the refrigeration mode has been initiated. (The green LED will be lit.)
2. The compressor will start after a 1-minute delay once power is applied.
3. The compressor will continue to run until it reaches its cut-out temperature (Pulldown).
4. The refrigeration cycle will continue for the next subsequent scheduled (6-hours) or demand defrost. The digital display will display the temperature reading for 10 minutes after defrost.
5. The above process will repeat (steps 3 and 4) until the power is interrupted.
6. If power stops, the process will start over at step 1, and the time to subsequent defrost will reset.

TEMPERATURE ADJUSTMENT

Rotate the adjustment knob counter clockwise for a warmer setpoint or clockwise for a colder setpoint.

- While the temperature is being adjusted, the optional display shows the setpoint (cut out value). A few seconds after the temperature is set, the display reverts to showing the sensed temperature in the merchandiser.

ALARMS AND CODES

FLASHING TEMPERATURE OR SENSOR ALARM LED, E1 OR E2

If the Temperature or Sensor Alarm LED (red) on the controller and display is flashing, a temperature sensor has failed. The display shows E1 if the case sensor has failed or E2 if the evaporator sensor has failed.



If the merchandiser sensor fails, refrigeration will run continuously. Turn off, or repeat a duty cycle of a few minutes on and a few minutes off.

DEFROST TERMINATION SWITCH

Merchandisers may use a defrost termination switch, instead of an evaporator sensor to terminate a defrost cycle. The defrost termination switch is temperature activated and senses the completion of defrost.

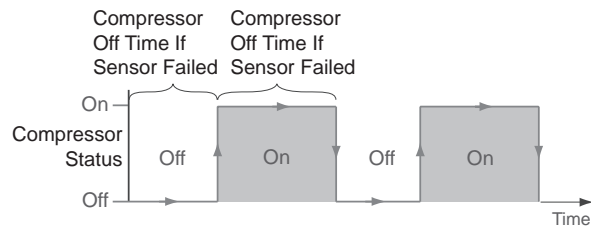

MANUAL DEFROST

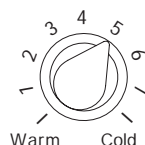

1. Note location of knob setting

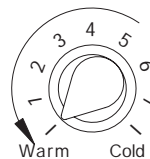

2. Rotate knob fully counterclockwise until it stops (full warm - "OFF" position)

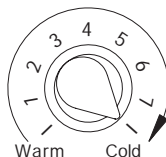

3. After 10 seconds, but before 20 seconds, rotate knob fully clockwise until it stops (full cold position)

Note:

This procedure initiates a manual or forced defrost.

IMPORTANT: Return the control knob to its original setting (Step 1) once the manual defrost has been initiated.

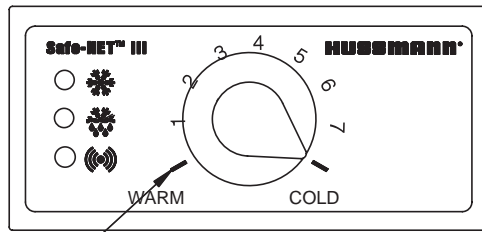

“OFF” Position — Safe-NET III Control
Set at Full Cold Position

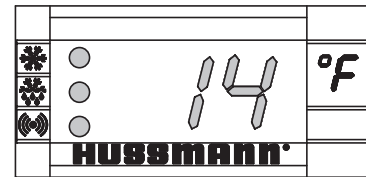

Display - at Full Cold
Model DDSS-4MC

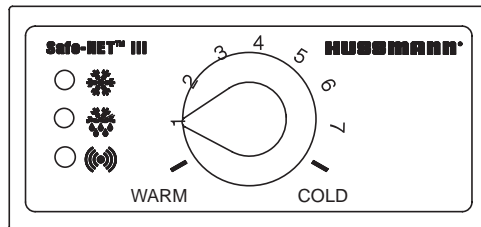

Safe-NET III Control
1 Position

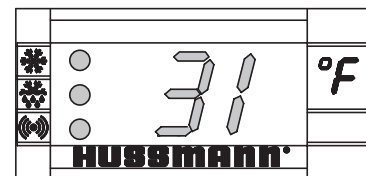

Display - at #1 Position
Model DDSS-4MC

TEMPERATURE ADJUSTMENT

1. Rotate the adjustment knob counter clockwise for a warmer setpoint or clockwise for a colder setpoint.
2. While adjusting the temperature, the display shows the setpoint (cut out value). A few seconds after the temperature is set, the controller reverts to the sensed temperature in the merchandiser.
3. To verify merchandiser settings, turn the dial to warm and cold as shown above. Output readings should be within one degree of the temperatures shown above.

SENSOR LOCATION

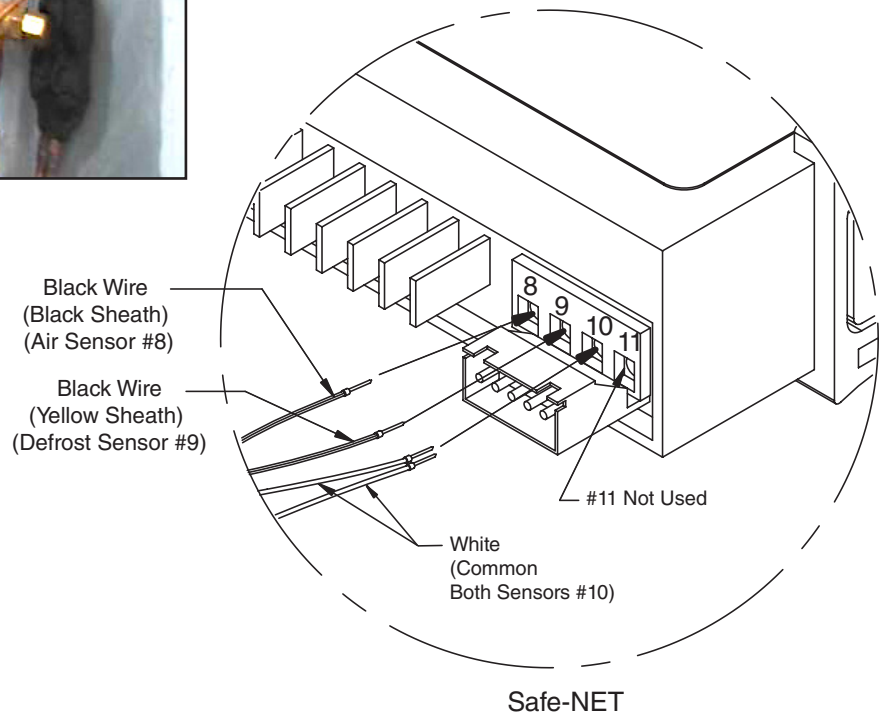
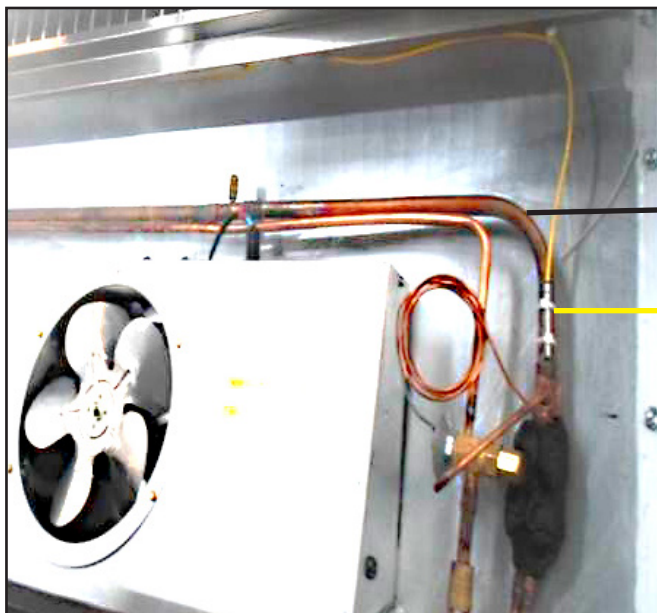
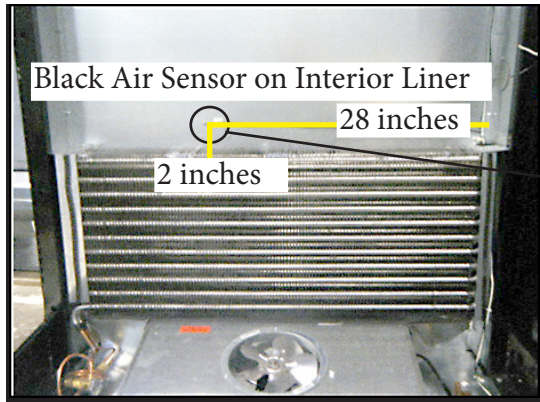

CONTROLS and ADJUSTMENTS

Refrigeration Controls			Defrost Controls			
Model	Product Application	Discharge Air Temperature	Defrost Frequency (per day)	Type of Defrost	Termination Temperature	Failsafe Time (Minutes)
DDSS-4MC	Medium Temp. (Dairy, Deli)	24° F to 32° F	4	Off Time	45° F	40

1. The Safe-NET III Controller controls refrigeration temperature. This is factory installed in the control panel. Adjust this control knob to maintain the discharge air temperature shown. Measure discharge air temperatures at the center of the honeycomb.

Defrosts are time initiated and temperature terminated for self contained and remote, including Koolgas models. The defrost setting is factory set as shown above.

To ensure a thorough defrost, defrost must be terminated by the temperature termination setting — not by time.

THERMOSTATIC EXPANSION VALVE (TEV)

Each self contained merchandiser has its own evaporator coil and a **pre-set** thermostatic expansion valve (TEV). The TEV has been factory set at design conditions to provide the recommended performance.

TEV Adjustment

Expansion valves may be adjusted to fully feed the evaporator. Before attempting to adjust valves, make sure the evaporator is clear or only lightly covered with frost, and the merchandiser is within 10°F of its expected operating temperature.

Adjust the valve as Follows:

- a. Attach a probe to the suction line near the expansion valve bulb.
- b. Obtain a pressure reading from the factory installed Schraeder valve. Convert the pressure reading to a saturated temperature for the refrigerant.

Temperature (b) minus Temperature (a) is the superheat. The valve should be adjusted so that the greatest difference between the two temperatures is 3°F to 5° F.

Make adjustments of no more than 1/2 turn of the valve stem at a time and wait for at least 15 minutes before rechecking the probe temperature and making further adjustments.

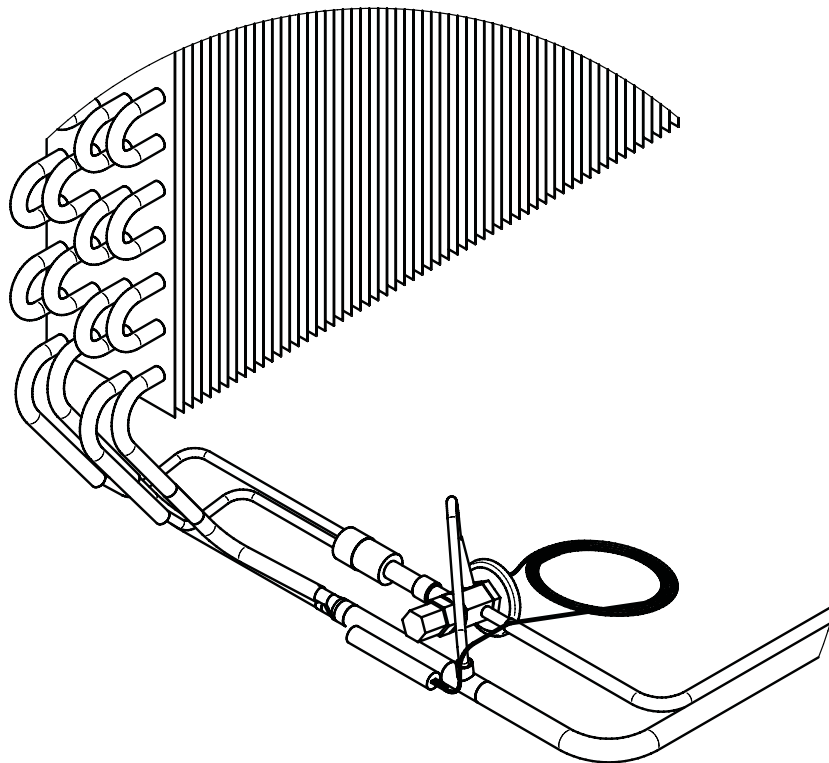

LOAD LIMITS

Each merchandiser has a load limit decal. Shelf life of perishables will be short if load limit is violated.

AT NO TIME SHOULD MERCHANDISERS BE STOCKED BEYOND THE LOAD LIMITS INDICATED.

DO NOT BLOCK HONEYCOMB.



STOCKING

Product should NOT be placed inside the merchandisers until merchandisers are at proper operating temperature.

Allow merchandiser 24 hours to operate before loading product.

Proper rotation of product during stocking is necessary to prevent product loss. Always bring the oldest product to the front and set the newest to the back.

AIR DISCHARGE AND RETURN FLUES MUST REMAIN OPEN AND FREE OF OBSTRUCTION AT ALL TIMES to provide proper refrigeration and air curtain performance. Do not allow product, packages, signs, etc. to block these grilles. Do not use non-approved shelving, baskets, display racks, or any accessory that could hamper air curtain performance.

Do not allow product to be placed outside of the designated load limits in the illustration.



WARNING

Product will be degraded and may spoil if allowed to sit in a non-refrigerated area.

THERMOMETER

DDSS models have a thermometer. The thermometer is located at the top, interior of the merchandiser.

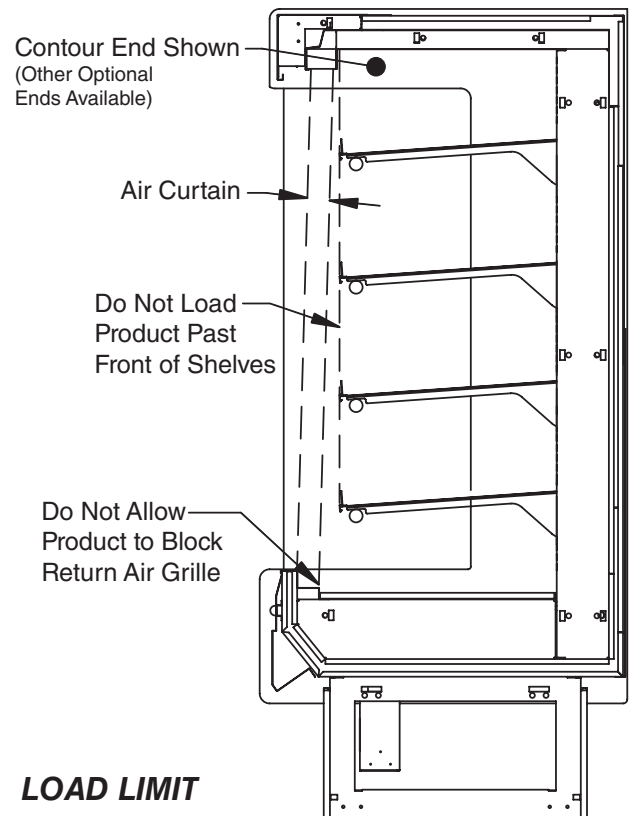

3-10 START UP / OPERATION

NOTES:

MAINTENANCE

CARE AND CLEANING

Long life and satisfactory performance of any equipment is dependent upon the care it receives. To ensure long life, proper sanitation and minimum maintenance costs, these merchandisers should be thoroughly cleaned, all debris removed and the interiors washed down, weekly.

Exterior Surfaces

The exterior surfaces must be cleaned with a mild detergent and warm water to protect and maintain their attractive finish. **NEVER USE ABRASIVE CLEANSERS OR SCOURING PADS.**

Interior Surfaces

The interior surfaces may be cleaned with most domestic detergents, ammonia based cleaners and sanitizing solutions with no harm to the surface. Self contained models empty into a limited capacity evaporation pan, which will overflow if excess water is used in cleaning.

Do NOT Use:

- Abrasive cleansers and scouring pads, as these will mar the finish.
- Coarse paper towels on coated glass.
- Ammonia-based cleaners on acrylic parts.
- Solvent, oil or acidic based cleaners on any interior surfaces.
- Do not use high pressure water hoses.

WARNING

Product will be degraded and may spoil if allowed to sit in a non-refrigerated area.

Do:

- Remove the product and all loose debris to avoid clogging the waste outlet.
- Store product in a refrigerated area such as a cooler. Remove only as much product as can be taken to the cooler in a timely manner.
- Disconnect electrical power before cleaning.**
- Thoroughly clean all surfaces with soap and hot water. **DO NOT USE STEAM OR HIGH WATER PRESSURE HOSES TO WASH THE INTERIOR. THESE WILL DESTROY THE MERCHANDISERS' SEALING CAUSING LEAKS AND POOR PERFORMANCE.**
- Take care to minimize direct contact between fan motors and cleaning or rinse water.
- Do NOT flood merchandiser with water. **NEVER INTRODUCE WATER FASTER THAN THE WASTE OUTLET CAN REMOVE IT.**

WARNING

Do NOT allow cleaning agent or cloth to contact food product.

SELF CONTAINED MODELS EMPTY INTO A CONDENSATE EVAPORATION PAN THAT WILL OVERFLOW IF TOO MUCH WATER IS INTRODUCED DURING CLEANING.

- Allow merchandisers to dry before resuming operation.
- After cleaning is completed, turn on power to the merchandiser.

WARNING

Do NOT use HOT water on Cold glass Surfaces. This can cause the glass to shatter and could result in personal injury. Allow glass fronts, to warm before applying hot water.

REMOVING SCRATCHES FROM BUMPER

Most scratches and dings can be removed using the following procedure.

1. Use steel wool to smooth out the surface area of the bumper.
2. Clean area.
3. Apply vinyl or car wax and polish surface for a smooth glossy finish.

CLEANING UNDER FAN PLENUM

To facilitate cleaning, the fan plenum is hinged.

After cleaning be sure the plenum is properly lowered into position OR PRODUCT LOSS WILL RESULT due to improper refrigeration.

WARNING

— LOCK OUT / TAG OUT —

To avoid serious injury or death from electrical shock, always disconnect the electrical power at the main disconnect when servicing or replacing any electrical component. This includes, but is not limited to, such items as doors, lights, fans, heaters, and thermostats.

WARNING

SHUT FANS OFF DURING CLEANING PROCESS.

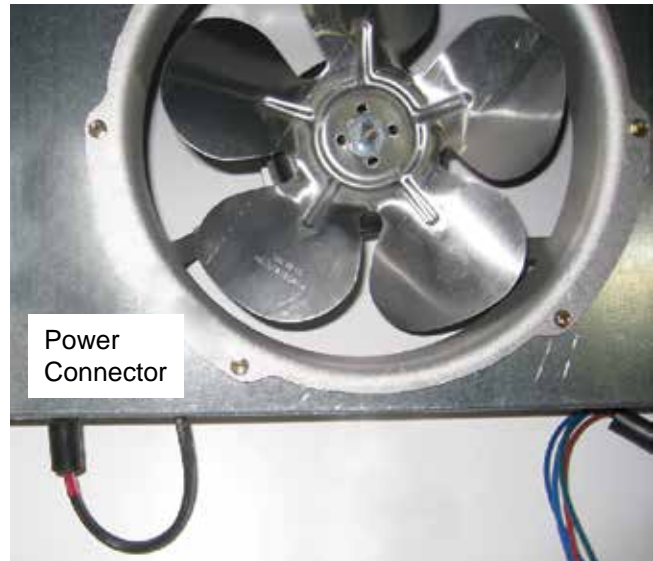

CAUTION

DO NOT FLOOD!

Use only enough water necessary to clean surface. Water must not drip down the case!

Never use ammonia based cleansers, abrasive cleansers, or scouring pads.

CLEANING STAINLESS STEEL SURFACES

Use non-abrasive cleaning materials, and always polish with grain of the steel. Use warm water or add a mild detergent to the water and apply with a cloth. Always wipe rails dry after wetting.

Use alkaline chlorinated or non-chlorine containing cleaners such as window cleaners and mild detergents. Do not use cleaners containing salts as this may cause pitting and rusting of the stainless steel finish. Do not use bleach.

CLEANING DISCHARGE HONEYCOMB

Discharge air honeycomb should be cleaned every six months. Dirty honeycomb will cause merchandisers to perform poorly. The honeycomb may be cleaned with a vacuum cleaner. Soap and water may be used if all water is removed from the honeycomb cells before replacing. Be careful not to damage the honeycomb.

1. Using a flat object such as a screw driver, behind the rear edge of the honeycomb on the right hand end, and gently pull down.
2. Clean with a mild detergent and warm water and dry the honeycomb.
3. After cleaning, replace in reverse order. Damaged honeycomb must be replaced.

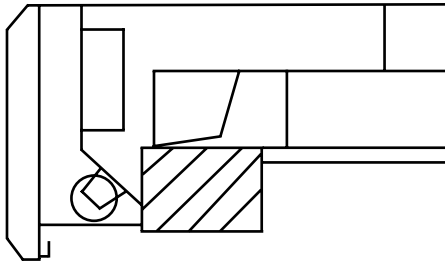

1. Installed Location

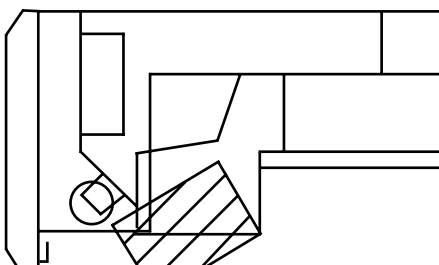

2. Push UP and IN

CLEANING COILS

Condenser coils should be cleaned at least once per month. Additional cleaning may be needed depending on the operational environment. A dirty condenser blocks normal airflow through the coils.



Airflow blockage increases energy consumption and reduces the merchandiser's ability to maintain operating temperature.

To clean the coils, use a vacuum cleaner with a wand attachment and a soft (non-metallic) brush to remove dirt and debris. Do not bend coil fins. Always wear gloves and protective eye wear when cleaning near sharp coil fins and dust particles.



PRECAUTION CLEANING PRECAUTIONS

When Cleaning:

- Do not use high pressure water hoses
- Do not introduce water faster than waste outlet can drain
- NEVER INTRODUCE WATER ON SELF CONTAINED UNIT WITH AN EVAPORATION PAN
- NEVER USE A CLEANING OR SANITIZING SOLUTION THAT HAS OIL BASE (these will dissolve the butyl sealants) or an AMMONIA BASE (this will corrode the copper components of the merchandiser)
- TO PRESERVE THE ATTRACTIVE FINISH:
- Use a water and a mild detergent for the exterior only
- Do NOT use a chlorinated cleaner on any surface
- Do NOT use abrasives or steel wool scouring pads (these will mar the finish)

CLEANING EVAPORATION PAN

The condensate water outlet empties into a limited capacity evaporation pan.

Debris or dirt accumulation inside the condensate evaporation pan or on the heater coil will reduce the pan's evaporation capacity and cause premature heater failure. The evaporation pan waste water will overflow and spill onto the floor if the heater is not properly operating.

Remove accumulated debris from the evaporation pan. Wipe down heater coil with a cloth and warm water. Be sure to remove any dirt, debris or liquids from the heater coil.

Water introduced during cleaning will cause the evaporation pan to overflow.

NEVER USE SHARP OBJECTS AROUND COILS. Use a soft brush or vacuum brush to clean debris from coils. ***Do not puncture coils!*** Do not bend fins. Contact an authorized service technician if a coil is punctured, cracked, or otherwise damaged.

ICE in or on the coil indicates the refrigeration and defrost cycle is not operating properly. Contact an authorized service technician to determine the cause of icing, and to make adjustments as necessary. To maintain product integrity, move all product to a cooler until the unit has returned to normal operating temperatures.

WARNING

Evaporation Pan is Hot!

and poses risk of bodily injury – Always Wear gloves and protective eye wear when servicing. Turn off evaporation pan heater, and allow pan to cool.

MAINTAINING FLUORESCENT LAMPS (IF APPLICABLE)

Many of the self-contained cases are equipped with LEDs. For cases with fluorescent lamps, follow these directions to ensure long-lasting life of the lights:

Fluorescent lamps should not be allowed to run to failure. If a re-lamp schedule is not in place, the tubes should be inspected for signs of degradation (blackened ends). Degraded or failed tubes should be replaced.

Allowing severely degraded lamps to operate may cause a ballast failure or could expose the lamp holder to excessive heat. Replacing degraded bulbs is more cost effective than replacing ballast and lamp-holders. Traditional re-lamp programs are 18-to-24 month intervals. In the absence of a re-lamp program, a yearly inspection of the lighting system is recommended.

1. Inspect all lamp sockets and plug-receptacle connections for signs of arching. Replace any component that shows signs of arching.
2. Make sure all unused receptacles have their close-off covers securely installed.
3. Make sure proper cleaning procedures are followed. Lights and fans **MUST** be turned off when a case is cleaned and **MUST** be allowed to dry before turning power back on.
4. Do not use a pressure nozzle to clean inside of case.

SERVICE

REPLACING FAN MOTORS AND BLADES

Should it ever be necessary to service or replace the fan motors or blades be certain that the fan blades are reinstalled correctly. **THE BLADES MUST BE INSTALLED WITH RAISED EMBOSSED (PART NUMBER ON PLASTIC BLADES) POSITIONED AS INDICATED ON THE PARTS LIST.**

For access to these fans:

1. Remove product and place in a refrigerated area. Turn off power to the merchandiser.
2. Remove bottom display pans.
3. **Disconnect fan from wiring harness.**
4. Remove fan blade.
5. Lift fan plenum and remove screws holding bottom of motor to fan basket.
6. Replace fan motor and blade.
7. Lower fan plenum.
8. Reconnect fan to wiring harness.
9. Turn on power.
10. Verify that motor is working and blade is turning in the correct direction.



WARNING

Product will be degraded and may spoil if allowed to sit in a non-refrigerated area.



WARNING

— LOCK OUT / TAG OUT —

To avoid serious injury or death from electrical shock, always disconnect the electrical power at the main disconnect when servicing or replacing any electrical component. This includes, but is not limited to, such items as doors, lights, fans, heaters, and thermostats.

11. Close air gaps under fan plenum. Warmer air moving into refrigerated air reduces effective cooling. If the plenum does not rest against the case bottom without gaps, apply foam tape to the bottom of the fan plenum to reduce improper air movement. Use silicone sealant to close other gaps.
12. Reinstall display pans. Bring merchandiser to operating temperature before restocking.

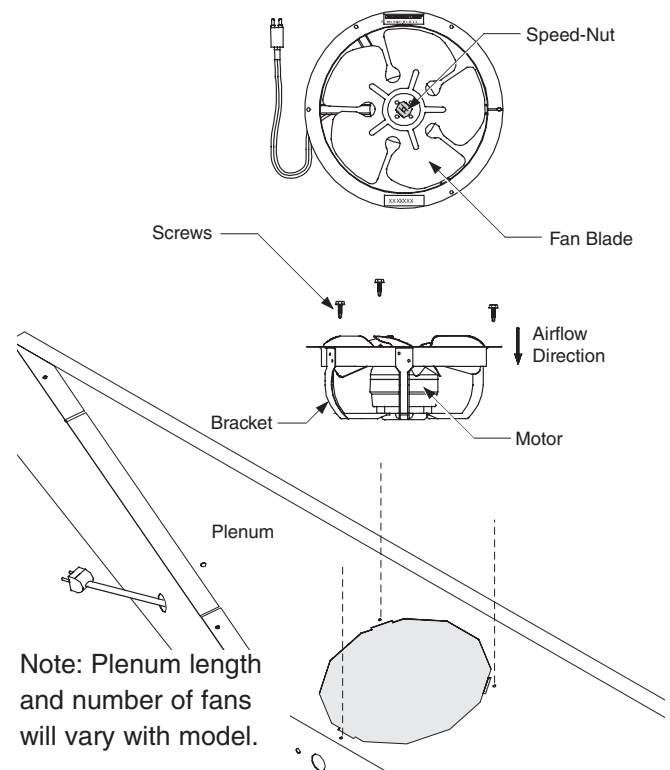

REPLACING ELECTRONIC BALLASTS OR LED POWER SUPPLIES

The canopy ballast or LED power supply is located in the electrical box on top of the merchandiser.

To gain access:

1. **DISCONNECT THE ELECTRICAL POWER TO THE MERCHANDISER.**
2. Remove top panel by removing the screws on top of the case.



3. The ballast is located under the top sign.



REPLACING FLUORESCENT LAMPS OR LED FIXTURES

The lamp is removed as shown in the image below. The lamp twists out of its end cap.

The lamp can be replaced without removing the top panel.



WARNING

Fluorescent lamps contain mercury vapor. Mercury exposure at high levels can harm the brain, heart, kidneys, lungs, and immune system of people of all ages. Do not break or puncture fluorescent lamps. Dispose of, or store, all fluorescent lamps in accordance with Federal (40 CFR 273), State, and local hazardous waste requirements. Refer to <http://www.epa.gov/mercury/about.htm>

REPAIRING ALUMINUM COIL

The aluminum coils used in Hussmann merchandisers may be easily repaired in the field. Materials are available from local refrigeration wholesalers.

NOTE:

Hussmann Aluminum melts at 1125°F (607°C)

Aladdin 3-in-1 rod at 732°F (389°C)

X-Ergon Acid core at 455°F (235°C)

Technique:

1. Locate Leak.
2. REMOVE ALL PRESSURE.
3. Brush area UNDER HEAT.
4. Use PRESTOLITE TORCH ONLY.
Number 6 tip.
5. Maintain separate set of stainless steel brushes, and USE ONLY ON ALUMINUM.
6. Tin surface around area.
7. Brush tinned surface UNDER HEAT, thoroughly filling the open pores around leak.
8. Repair leak. Let aluminum melt solder, NOT the torch.
9. Don't repair for looks. Go for thickness.
10. Perform a leak check.
11. Wash with water.
12. Cover with a good flexible sealant.

DOE 2012
Energy Efficiency
Compliant

Hussmann refrigerated merchandisers configured for sale for use in the United States meet or surpass the requirements of the DOE 2012 energy efficiency standards.

Models**DDSS4-MC**

Standard Parts		
Description	Part Number	
LH End (Solid) Standard	0512892	X
RH End (Solid) Standard	0512895	X
LH View End	0513316	X
RH View End	0513221	X
End Acrylic (View end)	0512737	X
Front Bumper (Black)	0512899	X
Evap Fan Harness Main Feed	0376608	X
Evap Fan Harness	0376609	X
Air Sensor (Black) 4000MM	0510533	X
Defrost Sensor (Yellow) 4000MM	0510532	X
Safe-Net III Controller 65C	0524122	X
Safe-Net III Display (F°) 65C	1H59052001	X
Safe-Net III Display Interface Cable (1M)	0509783	X
Safe-Net III Control Harness	0513058	X
Condensate pan heater relay SPDT NC 208V	0342599002	X
Compressor Relay (T92P7A22-240)	1804241	X
Power Switch	03S422	X
Caster	35S088	X
Honeycomb	29S866	X
Power Cord NEMA 6-20P	1804385	X
Flourscent light (Canopy) F32T8	06S214	X
Safety Shield for Flourscent light (Canopy)	06S07414	X
Ballast	06S187	X
LED Power Supply (optional)	0518898	X
LED Light (optional)	0515965	X
Lamp Holder	06S248	X
Light Switch	03S176	X
Flue Glass	29S863	X
Sign Panel (acrylic)	29S8731	X
Glass Shelf 13" complete	0513065	X
Glass for Shelf 13"	0513062	X
Glass Shelf 10" complete	145996	X
Glass for Shelf 10"	29S870	X

Refrigeration

DDSS4-MC

Description	Part Number	
Condensing Unit Assy (134a) Complete w/ condensate pan	0511124	X
Compressor RST55C1E-CAV-201	E110101001	X
Condenser Coil	2100226	X
Drier (C052-S)	17S507	X
Condenser Fan Motor & Bracket	7408727	X
Condenser Fan Blade	0500354	X
Hi-Pressure Switch	03S558	X
Retainer ring Hi-Pressure Switch	05S625	X
Pull-Out coil assy	0511147	X
Assembly Evaporator Coil (Complete)	0511121	X
Evaporator coil	26S138	X
Distributor TYP 1 BA1016-01	17S579	X
TXV FBSE-1/2 C	0515679	X
Evaporator Fan Motor (Motor 12W,basket,less blade)	0523011	X
Evaporator Fan Blade	014278002	X

Condensate Pan

DDSS4-MC

Description	Part Number	
Electric Condensate Pan Assy (w/heater & float switch)	1H11037001	X
Condensate Pan Heater (750w)	1H07734001	X
Float Switch	1804342	X

Sheel Metal Replacement Parts Painted

DDSS4-MC

Description	Part Number	
Front Access Panel	0511144	X
Panel Top Sign	144711	X
Return Air Grille (Stainless Steel)	146721	X
Bottom Shelf	0511142	X
LH End Panel -Base	0511148	X
RH End Panel -Base	0511145	X
Metal Shelf 10" X 4' (optional)	22S3021	X
Metal Shelf 12" X 4' (optional)	22S3022	X

All these part numbers below are painted assemblies

DDSS-4MC

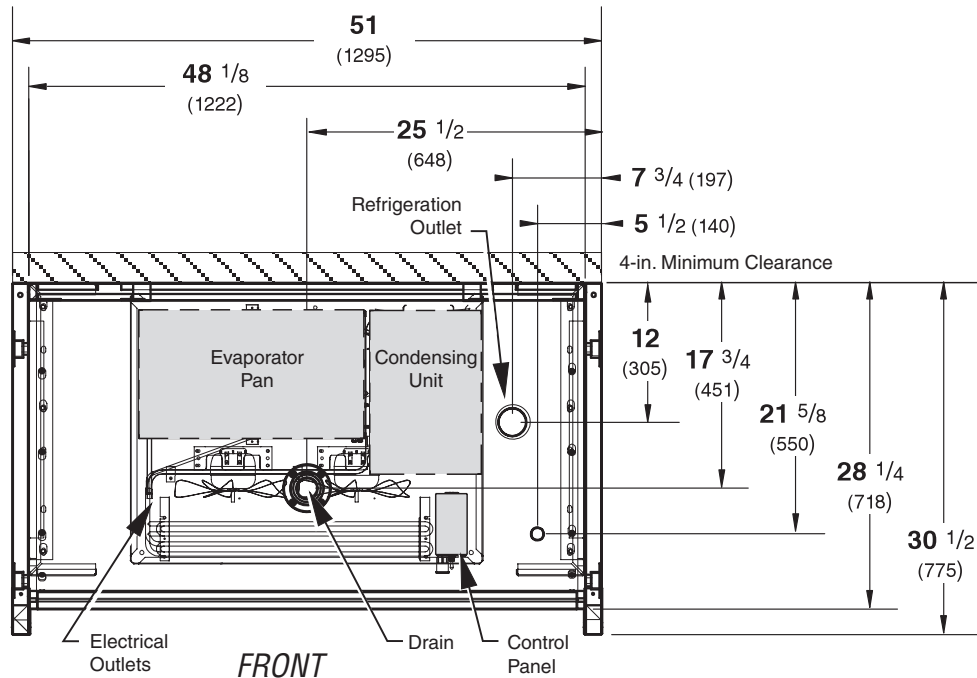

General

Case Length (*Note: Includes One Pair Ends*) 4ft (51) (1295)
 Maximum O/S dimension of case back to front 30 1/2 (775)
 (*Note: Includes bumper*)

Waste Outlet

RH end of case (*from outside of End Assembly*) 25 1/2 (648)
 to center of waste outlet

Dimensions shown as inches and (mm).

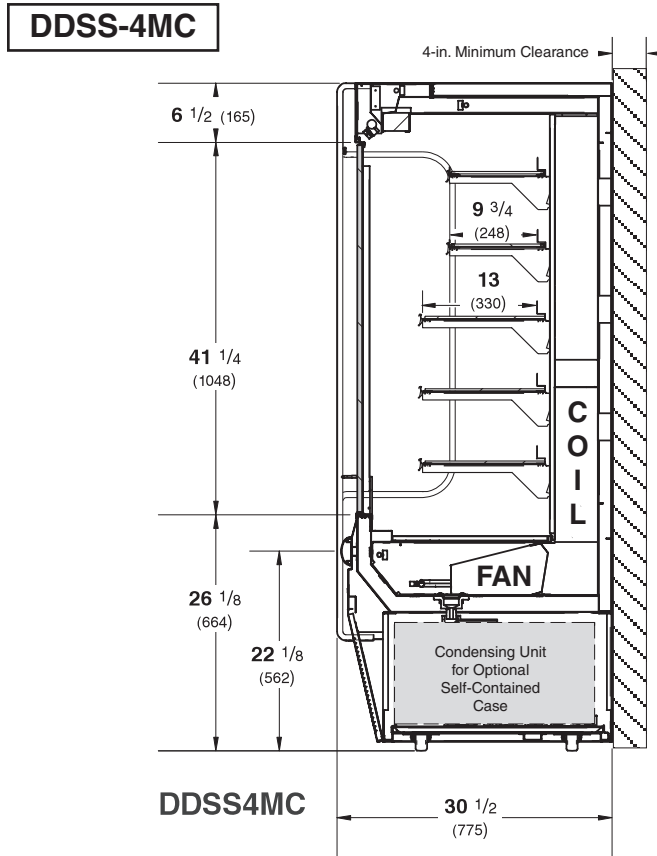

REFRIGERATION DATA

Note: This data is based on store temperature and humidity that does not exceed 80°F and 55% R.H. unless otherwise stated. Schedule defrost at night while lights are off.

DDSS-4MC

Thermostat

Setting CI/CO (°F)

Position #1 34 / 31 position #7 34 / 14

Condensing Unit (hp) 1

Condensing Unit

Capacity 9992

(Btu/hr at std. rating conditions)

DEFROST DATA

Frequency (hr) 6

OFFTIME

Failsafe (minutes) 40

Defrost Termination

Pressure (psig) 45°F

PHYSICAL DATA

Refrigerant Charge

DDSS-4MC 44 oz 1.248 kg

Electrical Data

Note: These are rated values for individual components and should not be added together to determine total merchandiser electrical load.

DDSS-4MC

Number of Fans – 12W	1			
	Self-Contained		Remote	
Evaporator Fans	Amperes	Watts	Amperes	Watts
230V 60Hz Standard 0.33	0.33	50	0.12	18
Condensate Pan Heaters (230V)	3.8	750	3.8	750
Condensing Unit (208/230V, 1Ph, 60Hz) Standard — Self-Contained				
Compressor LRA	33.7			
Compressor RLA	6.8			
Minimum Circuit Ampacity — Self-Contained				
230V 1Ph 60Hz Standard	10.85			
230V 1PH 60Hz Energy Efficient	10.67			
Maximum Over Circuit Protection 208/230V — Self-Contained	20			
Maximum Circuit Ampacity — Remote				
230V 1Ph 60Hz Standard	4.65			
Maximum Over Circuit Protection 208/230V — Remote	15			

DDSS-4 / DDSS4MC

AHRI Total Display Area ¹ (Sq Ft/Case) 13.01 ft² /case (1.21 m² /case)

¹ Computed using AHRI 1200 standard methodology:
Total Display Area, ft² [m²] / Unit of Length, ft [m]

ESTIMATED SHIPPING WEIGHT ²

Case	Self Contained	with Shipping Crate	End
lb (kg)	547 (248kg)	659 (299kg)	Included

Actual weights will vary according to optional kits included.

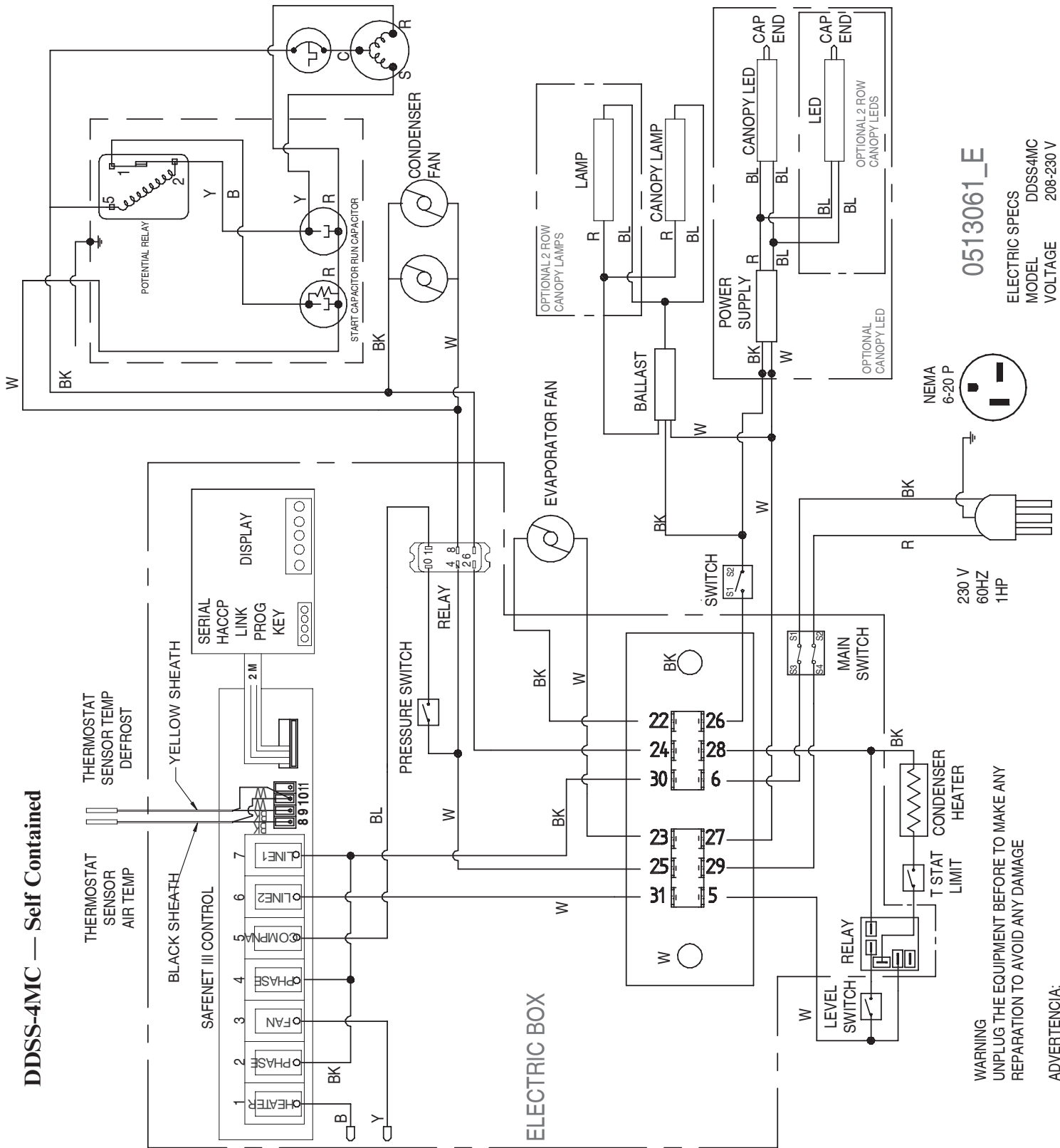

DDSS-4MC — Self Contained

0513061_E

ELECTRIC SPECS
 MODEL DDSS4MC
 VOLTAGE 208-230 V
 FREQUENCY 60 HZ
 COMPRESSOR RST55C1E-CAV COPELAND



230 V
 60HZ
 1HP

WARNING
 UNPLUG THE EQUIPMENT BEFORE TO MAKE ANY REPAIRATION TO AVOID ANY DAMAGE

ADVERTENCIA:
 DESCONECTAR EL EQUIPO ANTES DE HACER CUALQUIER REPARACION, PARA EVITAR ALGUN DAÑO.



HUSSMANN[®]

**To obtain warranty information
or other support, contact your
Hussmann representative.
Please include the model and
serial number of the product.**

Hussmann Corporation, Corporate Headquarters: Bridgeton, Missouri, U.S.A. 63044-2483 01 October 2012