

We reserve the right to change or revise specifications and product design in connection with any feature of our products. Such changes do not entitle the buyer to corresponding changes, improvements, additions or replacements for equipment previously sold or shipped.

Item	Part #	Description	Wiring Item #
<b>FAN ASSEMBLIES, AND THERMOSTATS</b>			
(A)	0378349	Fan Motor, Evaporator (MO.4410311)	(1)
	0142780	Fan Blade Embossing toward motor (FB.0142780)	

NOTE: Changed items have been underlined.



# Engineering Plan Views

Dimensions are shown as inches & (mm).





## PHYSICAL DATA

Merchandiser Drip Pipe (in.)	1 1/2
Merchandiser Liquid Line (in.)	3/8
Merchandiser Suction Line (in.)	7/8

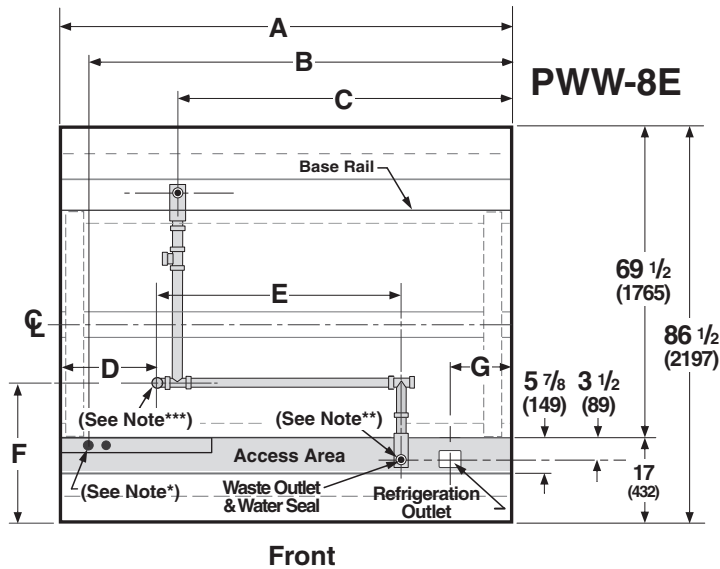
### 86 Inch Wide Island Bulk Produce

11-2010



General	4 Ft	6 Ft	8 Ft	12 Ft
<b>(A)</b> Case length <i>Each End and Partition adds 1 1/2 in. (38 mm) to the length of the lineup.</i> Maximum outside dimension of case back to front (includes bumper)	48 1/4 (1226)	72 1/4 (1835)	96 3/8 (2448)	144 1/2 (3670)
Front of splashguard to outside edge of base rail	5 7/8 (149)	5 7/8 (149)	5 7/8 (149)	5 7/8 (149)
Back of case to outside edge of front base rail	69 1/2 (1765)	69 1/2 (1765)	69 1/2 (1765)	69 1/2 (1765)
Front of case to outside edge of front base rail	17 (432)	17 (432)	17 (432)	17 (432)
Width of base rail	2 1/8 (54)	2 1/8 (54)	2 1/8 (54)	2 1/8 (54)
Stub up area between front base rail and splashguard	4 7/8 (124)	4 7/8 (124)	4 7/8 (124)	4 7/8 (124)
<b>Electrical Service</b> 				
<b>(B)</b> Righthand end of case to center of farthest knockout Length of electrical raceway <i>*Note: Electrical field wiring connection point.</i>	47 1/4 (1202)	71 1/4 (1810)	95 3/8 (2423)	143 5/8 (3650)
	11 7/8 (303)	34 5/8 (878)	34 5/8 (878)	34 5/8 (878)
<b>Waste Outlet</b> 				
<b>(C)</b> Right end of case to center of waste outlet	24 1/8 (613)	46 5/8 (1184)	72 1/4 (1835)	72 1/4 (1835)
<b>Water Seal</b> 				
Edge of water seal to center of waste outlet	4 (102)	4 (102)	4 (102)	4 (102)
Center of waste outlet to outside edge of front base rail	3 1/2 (89)	3 1/2 (89)	3 1/2 (89)	3 1/2 (89)
<b>** Note: Field installed water seal outlets, tees, and connectors are shipped with case</b>				
<b>Drip Pipe Outlet</b> 				
<b>(D)</b> Left end of case to center of drip pipe outlet	20 3/8 (517)	19 1/2 (495)	19 1/2 (495)	68 1/2 (1740)
<b>(E)</b> Center of waste outlet to center of drip pipe outlet	3 3/4 (95)	24 3/4 (629)	51 7/8 (1318)	3 3/4 (95)
<b>(F)</b> Front of case to center of drip pipe outlet Outside diameter of drip pipe lines	24 7/8 (632)	25 7/8 (657)	25 7/8 (657)	24 7/8 (632)
	1 1/2 (38)	1 1/2 (38)	1 1/2 (38)	1 1/2 (38)
<b>***Note: Field drip pipe connection point.</b>				
<b>Refrigeration Outlet</b>				
<b>(D)</b> Right end of case to center of refrigeration outlet Center of refrigeration outlet to outside edge of front base rail	9 (230)	9 (230)	9 (230)	9 (230)
	3 1/2 (89)	3 1/2 (89)	3 1/2 (89)	3 1/2 (89)

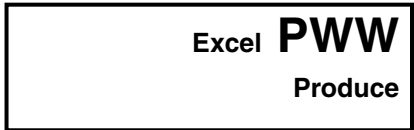

**REFRIGERATION DATA**

**Note:** This data is based on store temperature and humidity that does not exceed 75°F and 55% R.H.

	<b>PWW-4, 6, 8, 12E</b>
<b>Discharge Air (°F)</b>	34
<b>Evaporator(°F)</b>	24
<b>Unit Sizing (°F)</b>	22
 <b>Btu/hr/ft</b>	 <b>PWW-4, 6, 8, 12E</b>
<b>Parallel</b>	1200
<b>Conventional</b>	1325

**DEFROST DATA**

	<b>PWW-4, 6, 8, 12E</b>
<b>Frequency (hr)</b>	6
<b>Defrost Water (lb/ft/day)</b>	8
<i>(± 15% based on case configuration and product loading).</i>	
 <b>OFFTIME</b>	 <b>PWW-4, 6, 8, 12E</b>
<b>Temp Term (°F)</b>	N/A
<b>Failsafe (minutes)</b>	45
<b>Standard Defrost Thermostat</b>	NA

**CONVENTIONAL CONTROLS**

<b>Low Pressure Backup Control</b>	<b>PWW-4, 6, 8, 12E</b>
<b>CI/CO**</b>	17°/7° F

**Indoor Unit Only, Pressure Defrost**  
**Termination\*** 48° F

*\*Use a Temperature Pressure Chart to determine PSIG conversions.*

**PHYSICAL DATA**

<b>Estimated Charge **</b>	<b>PWW-4,6,8,12E</b>		
<b>4 ft</b>	1.4 lb	22oz	0.6 kg
<b>6 ft</b>	2.3 lb	37 oz	1.0 kg
<b>8 ft</b>	2.8 lb	45 oz	1.3 kg
<b>12 ft</b>	4.3 lb	69 oz	2.0 kg

**\*\*This is an average for all refrigerant types. Actual refrigerant charge may vary by approximately 0.5 lb (8 oz / 0.2 kg).**

**Dimensions are shown as inches & (mm).**

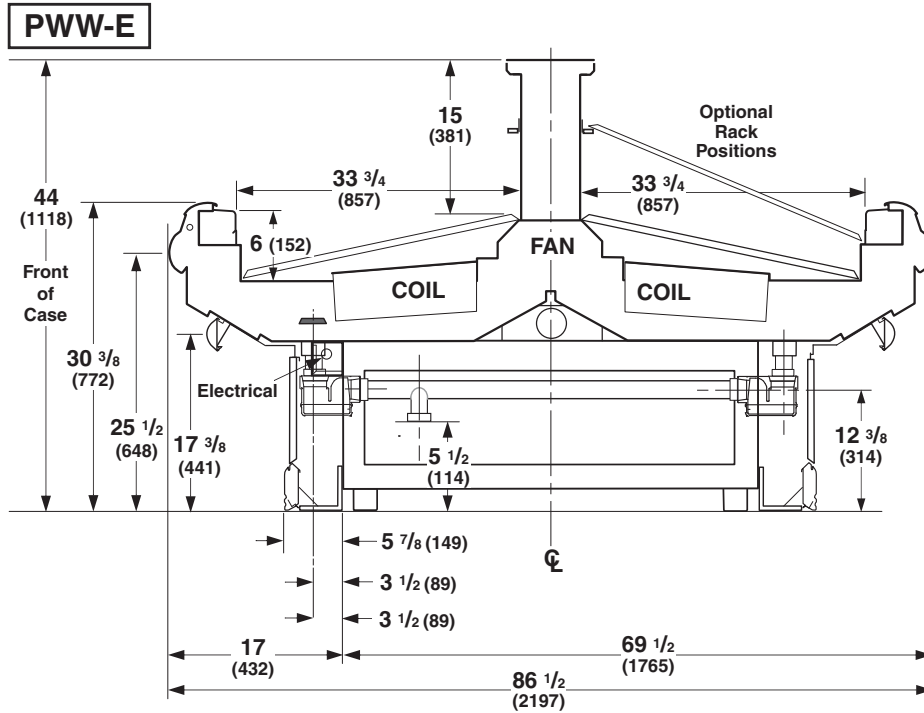

**NSF Certification**

This merchandiser model is manufactured to meet ANSI/NSF (National Sanitation Foundation) Standard #7 requirements for construction, materials & cleanability.

### Electrical Data

<b>Number of Fans</b>	<b>4 ft</b>	<b>6 ft</b>	<b>8 ft</b>	<b>12 ft</b>
<b>Refrigeration — 9W</b>	<b>1</b>	<b>1</b>	<b>2</b>	<b>3</b>
<b>Refrigeration — 9W (Export)</b>	<b>1</b>	<b>1</b>	<b>2</b>	<b>3</b>

<b>Merchandise</b>	<b>Amperes</b>				<b>Watts</b>			
	<b>4 ft</b>	<b>6 ft</b>	<b>8 ft</b>	<b>12 ft</b>	<b>4 ft</b>	<b>6 ft</b>	<b>8 ft</b>	<b>12 ft</b>
<b>Fans (Refrigeration)</b>								
Standard (120V 60Hz)	0.77	0.77	1.54	2.31	62	62	124	186
Energy Efficient (120V 60Hz)	0.38	0.38	0.76	1.14	25	25	50	75
Export (230V 50 Hz)	0.47	0.47	0.94	1.41	70	70	140	210

### Min. Circuit Ampacity

With Standard Fans (120V 60Hz)	0.97	0.97	1.74	2.51
With Energy Efficient Fans (120V 60Hz)	0.58	0.58	0.96	1.34
With Export Fans (230V 50 Hz)	0.67	0.67	1.14	1.61

<b>Maximum Over Current Protection 120V</b>	20	20	20	20
<b>Maximum Over Current Protection 230V</b>	15	15	15	15

### Standard Lighting

None

### Optional Lighting

None

### Optional Shelf Lighting

None

**Product Data**

<i>Recommended Usable Cube</i> <sup>1</sup> (Cu Ft/Ft)	7.08 ft <sup>3</sup> /ft (0.66 m <sup>3</sup> /m)
<i>ARI Total Display Area</i> <sup>2</sup> (Sq Ft/Ft)	5.67 ft <sup>2</sup> /ft (1.73 m <sup>2</sup> /m)
<i>Shelf Area</i> <sup>3</sup> (Sq Ft/Ft)	6.17 ft <sup>2</sup> /ft (1.88 m <sup>2</sup> /m)

<sup>1</sup> ARI Refrigerated Volume less shelving and other unusable space: Refrigerated Volume/Unit of Length, ft<sup>3</sup>/ft [m<sup>3</sup>/m]  
<sup>2</sup> Computed using ARI 1200 standard methodology: Total Display Area, ft<sup>2</sup> [m<sup>2</sup>]/Unit of Length, ft [m]  
<sup>3</sup> Shelf surface area is composed of bottom deck plus standard shelf complement, as shown in the Hussmann *Product Reference Guide*. The standard shelf complement for this model is NONE.

ESTIMATED SHIPPING WEIGHT <sup>4</sup>					
Case	4 ft	6 ft	8 ft	12 ft	Flat End (each)
<b>lb (kg)</b>	600 (272)	800 (363)	1000 (454)	1200 (544)	70 (32)

<sup>4</sup> Actual weights will vary according to optional kits included.

**Fan Wiring  
Offtime Defrost**

**1, 2 & 3 Fans**

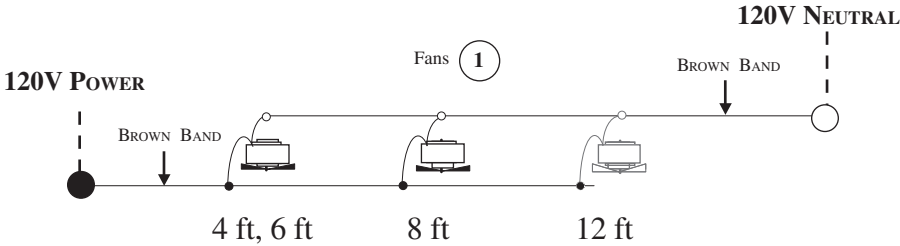

**WARNING**

All components must have a mechanical ground, and the merchandiser must be grounded.

CIRCLED NUMBERS = PARTS LIST ITEM NUMBERS

● = 120V POWER    ○ = 120V NEUTRAL