

**Warning:**  
Terminal block  
NOT for  
case-to-case  
wire connection!

We reserve the right to change or revise specifications and product design in connection with any feature of our products. Such changes do not entitle the buyer to corresponding changes, improvements, additions or replacements for equipment previously sold or shipped.

Item	Part #	Description	Wiring Item #	Item	Part #	Description	Wiring Item #
<b>FAN ASSEMBLIES, AND THERMOSTATS</b>				<b>HEATERS (CONTINUED)</b>			
A.	12W Standard Energy Efficient Fan Assembly		(1)	I.	Drain Pan Heater — Electric & KoolGas (120V)		(9)
	0477655	Fan Motor, Evaporator (MO.4410546)			0387036	(1) 2 Door Models (HE.4850239)	
	0461805	Fan Blade (FB.4780446)			0387037	(1) 3 Door Models (HE.4850240)	
B.	0474033	Standard Non-adjustable Defrost Thermostat (CT.4440726)	(2)		0387038	(1) 4 Door Models (HE.4850241)	
C.	Optional Adjustable Refrigeration Thermostat		(3)		0387039	(1) 5 Door Models (HE.4850242)	
D.	0344662	Defrost Limit Thermostat (CT.4440261)	(4)	<b>LED FIXTURES AND POWER SUPPLY</b>			
E.	0461814	Relay Control Thermostat or Fan and Anti-sweat Heater Thermostat (CT.4481296) (KG Only)	(5)	J.	0499399	Power Supply (EP.4481668)	(10)
<b>RELAYS</b>				K.	Door Lamp, LED		
F.	0342598	Anti-Sweat Control Relay (120V) (RL.4480238) (KG Only)	(6)		050908300	4100K Center (BU.4441330)	(11)
G.		Fan Control Relay	(7)		050908400	4100K End (BU.4441331)	(11)
	0342599	(208V) Electrical Defrost (RL.4480237)		<i>(Note: A complete list of vertical LED replacement lamps can be found at Hussmann.com/TechnicalInfoAndParts)</i>			
	0342598	(120V) KoolGas Defrost (RL.4480238)					
<b>HEATERS</b>							
H.	Electric Defrost Heaters – Front (208V)		(8)				
	3015372	(1) 2 Door Models (HE.4850346)					
	3015373	(1) 3 Door Models (HE.4850337)					
	3015374	(1) 4 Door Models (HE.4850347)					
	3015375	(1) 5 Door Models (HE.4850323)					
	Electric Defrost Heaters – Rear (208V)		(8)				
	3015376	(1) 2 Door Models (HE.4850358)					
	3015377	(1) 3 Door Models (HE.4850359)					
	3015378	(1) 4 Door Models (HE.4850360)					
	3015379	(1) 5 Door Models (HE.4850361)					

**Refer to INNOVATOR REACH-IN GLASS DOOR INSTALLATION AND SERVICE manual, P/N 0425683, for Innovator, Innovator II, or Innovator III door and frame replacement parts.**

Data sheet-LifeLine RL

Note: Revision J: Updated wiring diagrams on page 8 and 9.

# Engineering Plan Views

## LifeLine Premier RL - RM Plan View 05-2010

PHYSICAL DATA	
Merchandiser Drip Pipe (in.)	1 1/4
Merchandiser Liquid Line (in.)	3/8
Merchandiser Suction Line (in.)	5/8

Reach-In  
2, 3, 4 & 5 Door

Dimensions shown as inches and (mm).

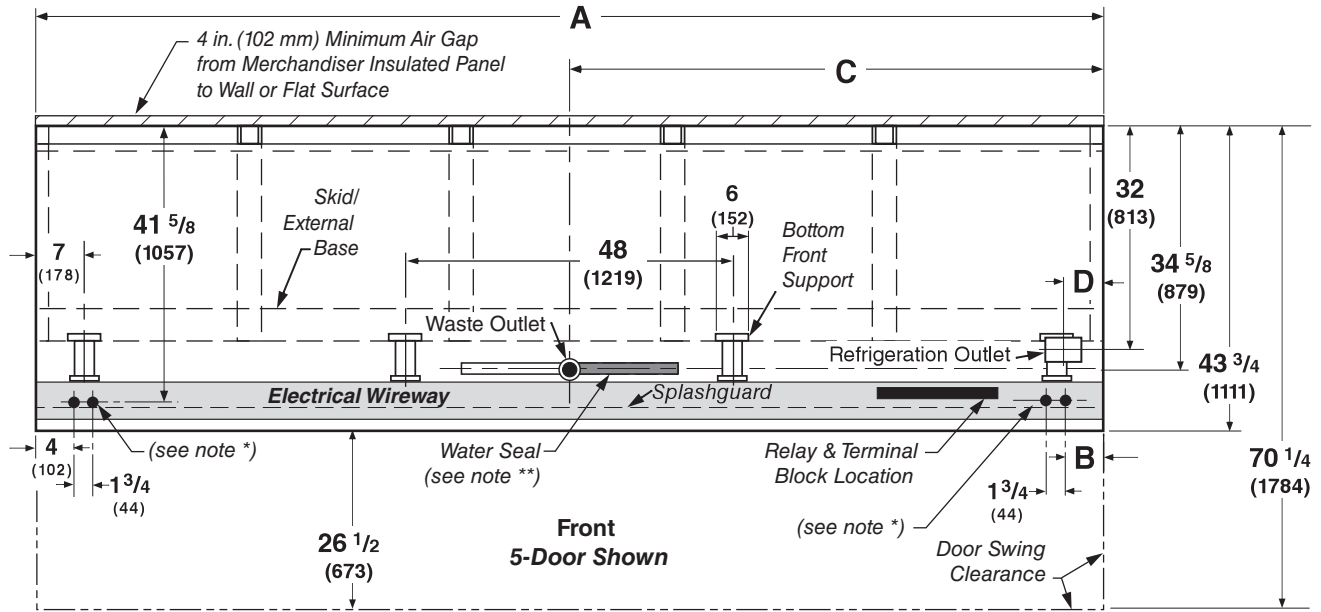

Base 5-door merchandiser is shown above, without Bump Out, Dry Goods sections, Partitions or Ends.

Illustrated below is a 4-door merchandiser with Dry Goods cabinets and Bump Out end partitions.

Refer to chart on Page 3 for detailed dimensional information on options.

## LifeLine Premier — Dry Goods \ Bump Out Plan View



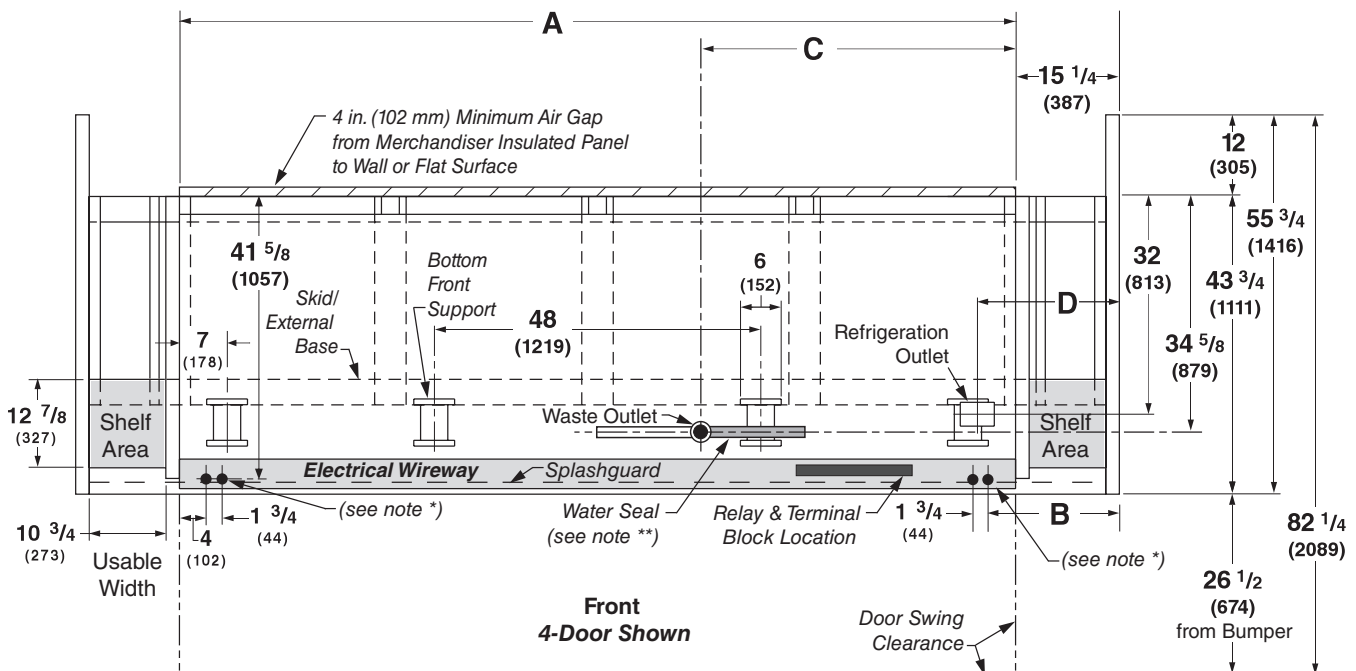

Dimensions shown as inches and (mm).

2, 3 & 4 Door



# Plan View Dimensions for LifeLine Premier Options

**LifeLine Premier RL**  
With Innovator Doors or Innovator III Doors  
Low Temperature

Abbreviations: DG = Dry Goods section      BO = Bump Out				
General	2 Dr	3 Dr	4 Dr	5 Dr
(A) Merchandiser Length	62 (1575)	92 1/2 (2350)	122 7/8 (3121)	153 3/8 (3896)
**NOTE: Each solid end adds approximately 2 3/8 in (60 mm) to length of line up; each partition add approximately 2 3/4 in (70 mm); case to case joints can add approximately 1/8 in (3 mm) for gasket material.				
(A) Merchandiser Length <b>BO</b> includes 2 bump-out ends	66 (1676)	96 1/2 (2451)	126 7/8 (3222)	157 3/8 (3997)
(A) Merchandiser Length <b>DG</b> includes 4 ends and dry goods cabinets	92 1/2 (2350)	123 (3124)	153 3/8 (3896)	NA
Maximum O/S dimension of merchandiser back to front ***	43 3/4 (1111)	43 3/4 (1111)	43 3/4 (1111)	43 3/4 (1111)
Maximum O/S dimension of merchandiser back to front <b>BO</b> ***	55 3/4 (1416)	55 3/4 (1416)	55 3/4 (1416)	55 3/4 (1416)
*** Includes bumper. Add 26 1/2 in. (673 mm) for door swing.				
Interior width of dry goods cabinet	10 3/4 (273)	10 3/4 (273)	10 3/4 (273)	NA
Interior depth of dry goods cabinet	12 7/8 (327)	12 7/8 (327)	12 7/8 (327)	NA
Back of merchandiser to rear of splashguard	39 7/8 (1013)	39 7/8 (1013)	39 7/8 (1013)	39 7/8 (1013)
Back of merchandiser to rear of splashguard <b>BO</b>	51 7/8 (1318)	51 7/8 (1318)	51 7/8 (1318)	51 7/8 (1318)
Width of Skid rail	3 3/4 (95)	3 3/4 (95)	3 3/4 (95)	3 3/4 (95)
Width of Bottom Front Support	6 (152)	6 (152)	6 (152)	6 (152)
Stub-up area between front support and splashguard	3 1/8 (79)	3 1/8 (79)	3 1/8 (79)	3 1/8 (79)
<b>Electrical Service</b> 				
(B) RH end of merchandiser to the center of nearest knockout	4 (102)	4 (102)	4 (102)	4 (102)
(B) RH end of merchandiser to the center of nearest knockout <b>BO</b>	6 (152)	6 (152)	6 (152)	6 (152)
(B) RH end of merchandiser to the center of nearest knockout <b>DG</b>	19 1/4 (489)	19 1/4 (489)	19 1/4 (489)	NA
RH end of merchandiser to the center of LH knockout	58 (1473)	88 1/2 (2248)	118 7/8 (3019)	149 3/8 (3794)
Back O/S of merchandiser with bump-out to center of knockout	53 5/8 (1362)	53 5/8 (1362)	53 5/8 (1362)	53 5/8 (1362)
* NOTE: Electrical Field Wiring Connection Point is at terminal.				
<b>Waste Outlet</b> 				
(C) Right end of merchandiser to center of waste outlet	23 7/8 (606)	54 1/4 (1378)	46 1/4 (1175)	76 5/8 (1946)
(C) Right end of merchandiser to center of waste outlet <b>BO</b>	25 7/8 (657)	56 1/4 (1429)	48 1/4 (1226)	78 5/8 (1997)
(C) Right end of merchandiser to center of waste outlet <b>DG</b>	39 (991)	69 1/2 (1765)	61 1/2 (1562)	NA
Back O/S of merchandiser with bump-out to center of waste outlet	46 7/8 (1184)	46 5/8 (1184)	46 5/8 (1184)	46 5/8 (1184)
<b>Water Seal</b> 				
Edge of water seal to center of waste outlet	13 (330)	13 (330)	13 (330)	13 (330)
Schedule 40 PVC drip pipe	1 1/4 (32)	1 1/4 (32)	1 1/4 (32)	1 1/4 (32)
** NOTE: Field installed water seal outlets, tees, and connectors are shipped with merchandiser.				
<b>Refrigeration Outlet</b> 				
(D) RH end of merchandiser to center of RH refrigeration outlet	5 3/8 (136)	5 3/8 (136)	5 3/8 (136)	5 3/8 (136)
(D) RH end of merchandiser to center of RH refrigeration outlet <b>BO</b>	7 3/8 (187)	7 3/8 (187)	7 3/8 (187)	7 3/8 (187)
(D) RH end of merchandiser to center of RH refrigeration outlet <b>DG</b>	20 5/8 (524)	20 5/8 (524)	20 5/8 (524)	NA
Back O/S of merchandiser with bump-out to center of refrigeration outlet	44 (1118)	44 (1118)	44 (1118)	44 (1118)
Outside bottom front supports from end of merchandiser	7 (178)	7 (178)	7 (178)	7 (178)
Outside bottom front supports from end of merchandiser <b>BO</b>	9 (229)	9 (229)	9 (229)	9 (229)
Outside bottom front supports from end of merchandiser <b>DG</b>	26 1/2 (673)	26 3/4 (679) RH 37 1/2 (952) LH	26 1/4 (667)	NA
Center bottom front support from Centerline	24 (610)	24 (610)	24 (610)	24 (610)
Center bottom front support from Centerline <b>BO</b>	24 (610)	24 (610)	24 (610)	24 (610)
Center bottom front support from Centerline <b>DG</b>	6 3/4 (171) LH	8 3/4 (222) RH	24 (610)	NA
<i>Distance between Center and Outside supports will vary.</i>				

# LifeLine Premier RL

With Innovator Doors or Innovator III Doors  
Low Temperature

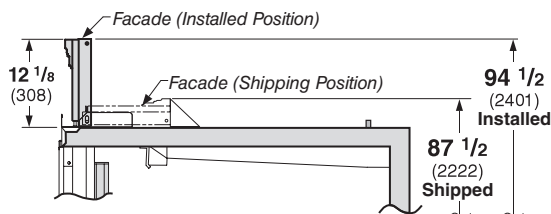

12 in. Straight Facade

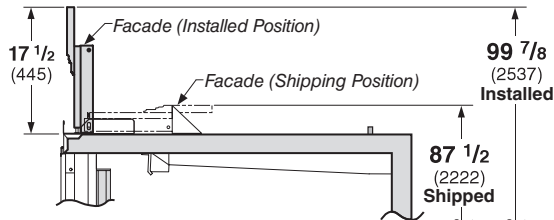

12 in. Arch Facade

## Facade Options in Cross Section

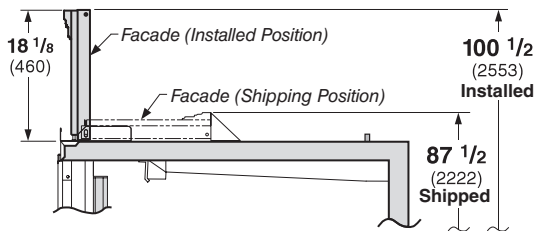

18 in. Straight Facade

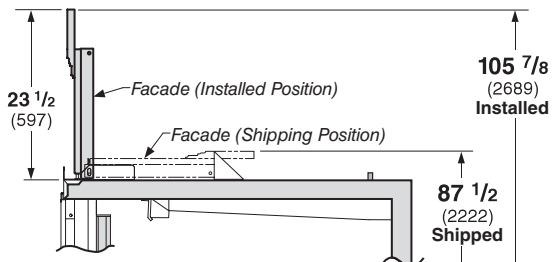

18 in. Arch Facade

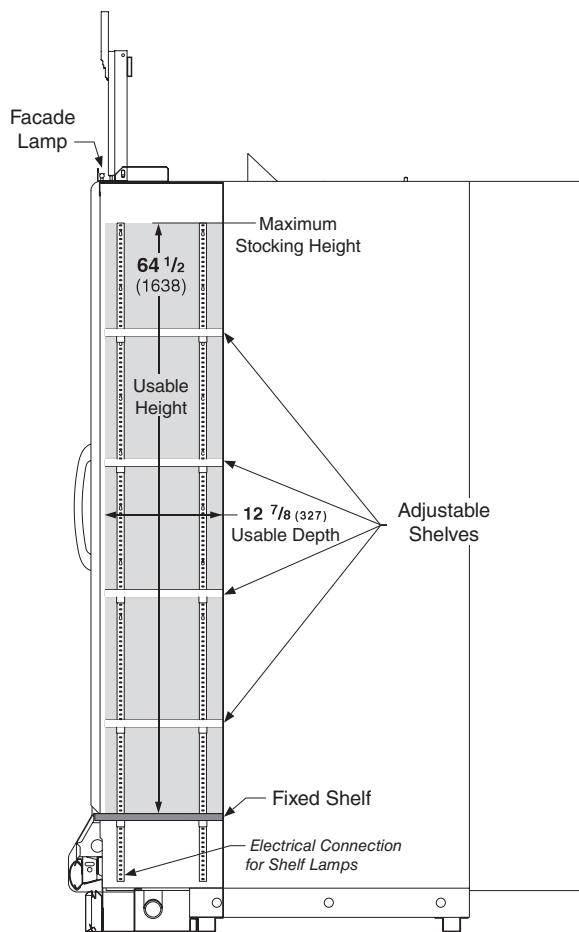

Dry Goods Cross-Section

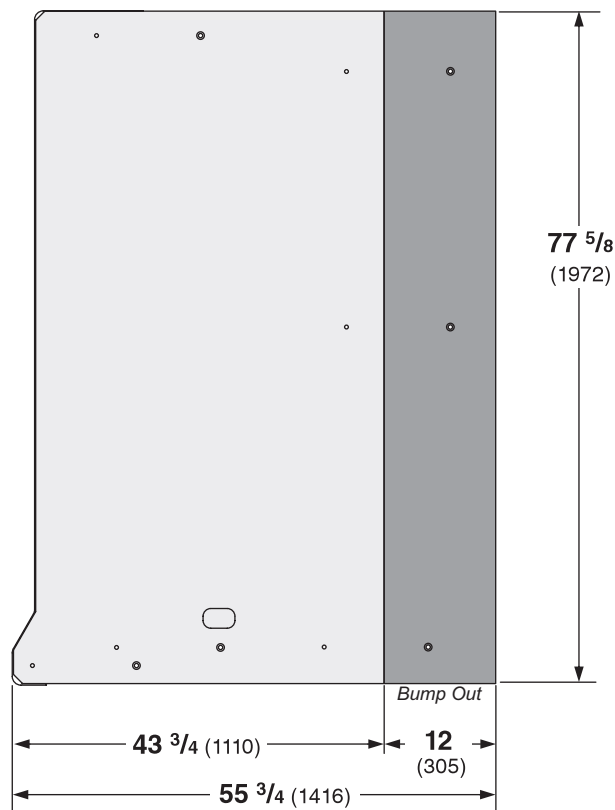

Partition and End Profiles

# LifeLine Premier Reach-in 2, 3, 4 and 5 Door Models



Hussmann refrigerated merchandisers configured for sale for use in the United States meet or surpass the requirements of the DOE 2017 energy efficiency standards.

**Standard Reach-in configuration consists of Innovator I doors, energy efficient fan motors, and EcoShine II LED vertical lighting.**

**LifeLine Premier RL - RM**

Dimensions shown as inches and (mm).

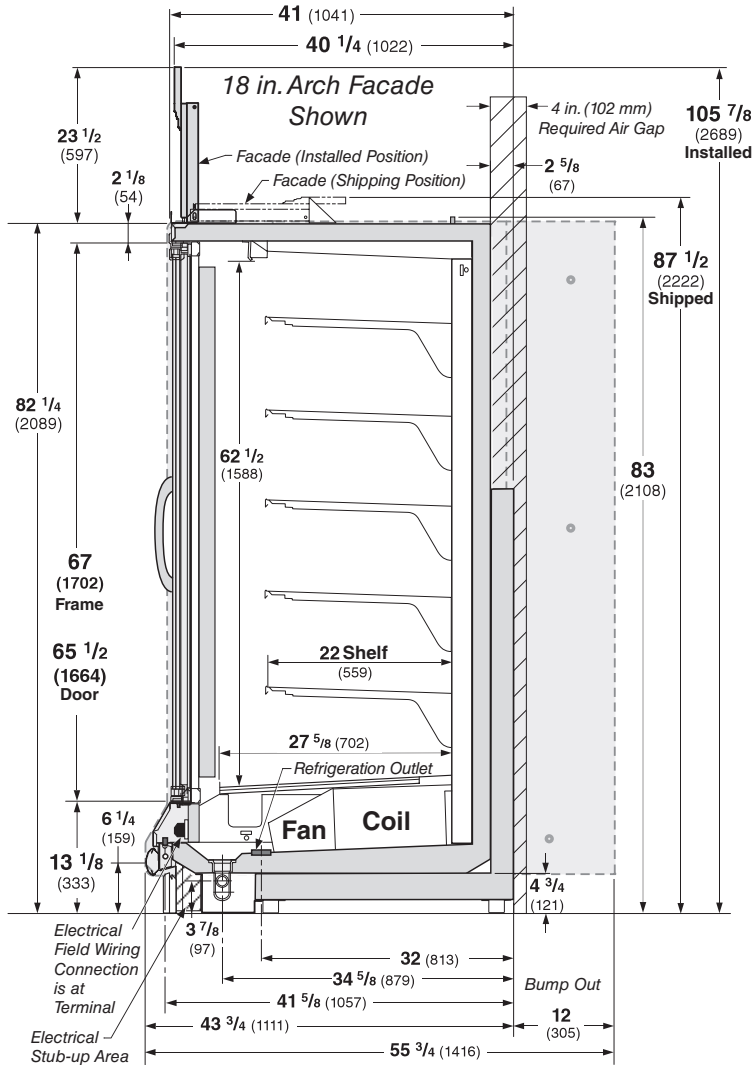

**See Page 4 for alternate facade heights.**

## LifeLine Premier RL

**With Innovator Doors or Innovator III Doors Low Temperature**

### REFRIGERATION DATA<sup>§</sup>

**Note:** This data is based on store temperature and humidity that does not exceed 75°F and 55% R.H.

	FF	IC	AHRI Rating*
Discharge Air (°F)	-5	-12	-2
Evaporator (°F)	-11	-19	-7
Unit Sizing (°F)	-14	-22	-10

\*With door A/S controller

### Btu/hr/Door

#### INNOVATOR

Parallel	955	1065	910
Conventional	970	1085	940

#### INNOVATOR III

Parallel	935	1035
Conventional	955	1055

<sup>§</sup> Average evaporator temperature shown. Use dew point for high glide refrigerants for unit sizing. Care should be taken to use the dew point in PT tables for measuring and adjusting superheat. Adjust evaporator pressure as needed to maintain discharge air temperature shown.

### DEFROST DATA

	FF	IC
Frequency (hr)	24	24
Defrost Water (lb/Dr/day) <sup>1.2</sup>	1.2	1.2

(± 15% based on case configuration and product loading.)

#### ELECTRIC

	FF	IC
Temp Term (°F)	48°	48°
Failsafe (minutes)	45	45

#### GAS

Duration (minutes)	20	20
--------------------	----	----

#### OFFTIME

Not Recommended

### CONVENTIONAL CONTROLS

#### Low Pressure Backup Control

	FF	IC
CI/CO (Temp °F)**	-18°/-34°	-26°/-45°

#### Indoor Unit Only, Pressure Defrost Termination (Temp °F)\*\*

Not Recommended

\*\*Use a Temperature Pressure Chart to determine PSIG conversions.

Anti-sweat controls are standard for all low temperature Reach-in cases with Innovator I doors.

Estimated Charge ***	RL		
2Dr	1.8 lb	29 oz	0.8 kg
3Dr	2.7 lb	43 oz	1.2 kg
4Dr	3.6 lb	58 oz	1.6 kg
5Dr	4.6 lb	74 oz	2.1 kg

\*\*\*This is an average for all refrigerant types. Actual refrigerant charge may vary by approximately 0.5 lb (8 oz / 0.2 kg).

### NSF Certification

This merchandiser model is manufactured to meet NSF/ANSI (National Sanitation Foundation) Standard #7 requirements for construction, materials & cleanability.

**LifeLine Premier RL**  
 With Innovator Doors or Innovator III Doors  
 Low Temperature

**Husmann recommends against frame heater cycling with *Innovator* doors or *Innovator III* doors to prevent door seals from freezing to the frames and tearing.**

**Electrical Data**

	2Dr	3Dr	4Dr	5Dr				
<b>Number of Fans—12W</b>	<b>2</b>	<b>3</b>	<b>4</b>	<b>5</b>				
	<b>Amperes</b>				<b>Watts</b>			
<b>Merchandiser</b>	<b>2Dr</b>	<b>3Dr</b>	<b>4Dr</b>	<b>5Dr</b>	<b>2Dr</b>	<b>3Dr</b>	<b>4Dr</b>	<b>5Dr</b>
<b>Energy Efficient Evaporator Fan</b>								
120V 50/60Hz	0.60	0.90	1.20	1.50	36	54	72	90
240V 50/60Hz Export Innovator	0.30	0.45	0.60	0.75	36	54	72	90
<b>Door Anti-sweat Heaters (on fan circuit)</b>								
120V 50/60Hz Innovator*	1.5	2.3	3.0	3.8	182	273	364	455
120V 50/60Hz Innovator III	0.9	1.3	1.7	2.2	104	156	208	260
240V 50/60Hz Export Innovator	0.8	1.2	1.5	1.9	183	275	367	459
220V 50/60Hz Export Innovator III	NA	NA	NA	NA	NA	NA	NA	NA
* Maximum door watts without anti-sweat cycling controls shown.								
<b>Frame Anti-sweat Heaters (on fan circuit)</b>								
120V 50/60Hz	0.78	1.18	1.57	1.97	94	141	188	236
240V 50/60Hz Export	0.45	0.67	0.89	1.12	107	161	215	269
<b>Minimum Fan Circuit Ampacity</b>								
120V 50/60Hz Innovator	3.1	4.9	6.8	8.6				
120V 50/60Hz Innovator III	2.5	3.9	5.5	7.0				
240V 50/60Hz Export Innovator	1.8	2.9	4.0	4.9				
240V 50/60Hz Export Innovator III	1.0	1.6	2.3	2.8				
<b>Maximum Over Current Protection 120V</b>	<b>20</b>	<b>20</b>	<b>20</b>	<b>20</b>				
<b>Maximum Over Current Protection 240V</b>	<b>15</b>	<b>15</b>	<b>15</b>	<b>15</b>				
<b>Defrost</b>								
Drain Heaters (120V)	0.63	1.25	2.00	2.57	75	150	240	300
(Export: 220V 50 Hz)	0.34	0.76	1.22	1.53	84	168	269	336
(Export: 240V 50 Hz)	0.41	0.83	1.33	1.67	100	200	320	400
<b>208V 1Ø Electric Defrost</b>	6.72	10.08	13.46	16.82	1400	2100	2800	3500
(Export: 220V 50 Hz)	7.11	10.66	14.24	17.79	1564	2345	3133	3914
(Export: 240V 50 Hz)	7.76	11.65	15.53	19.42	1864	2796	3728	4660
<b>Standard Vertical LED Lighting</b>	<b>2Dr</b>	<b>3Dr</b>	<b>4Dr</b>	<b>5Dr</b>	<b>2Dr</b>	<b>3Dr</b>	<b>4Dr</b>	<b>5Dr</b>
Husmann EcoShine II™ - A (120V)	0.31	0.46	0.62	0.77	37.1	55.6	74.2	92.7
Husmann EcoShine II™ - A (220V Export)	0.17	0.25	0.34	0.42	37.1	55.6	74.2	92.7
<b>Optional Vertical LED Lighting</b>								
Husmann EcoShine II™ - B (120V)	0.36	0.52	0.68	0.84	43.2	62.3	81.4	100.5
Husmann EcoShine II™ - B (220V Export)	0.20	0.28	0.37	0.46	43.2	62.3	81.4	100.5

Anti-sweat controls are standard for all low temperature Reach-in cases with Innovator I doors.

\* Dry Goods sections are not available on 5-Door models.

**Product Data (Refrigerated Area Only)**

<i>Recommended Usable Cube</i> <sup>1</sup> (Cu Ft/Dr)	23.46 ft <sup>3</sup> /Dr (0.66 m <sup>3</sup> /Dr)
<i>AHRI Total Display Area</i> <sup>2</sup> (Sq Ft/Dr)	13.04 ft <sup>2</sup> /Dr (1.21 m <sup>2</sup> /Dr)
<i>Shelf Area</i> <sup>3</sup> (Sq Ft/Dr)	29.32 ft <sup>2</sup> /Dr (2.72 m <sup>2</sup> /Dr)

<sup>1</sup> AHRI Refrigerated Volume less shelving and other unusable space: Refrigerated Volume/Unit of Length, ft<sup>3</sup>/ft [m<sup>3</sup>/m]

<sup>2</sup> Computed using AHRI 1200 standard methodology: Total Display Area, ft<sup>2</sup> [m<sup>2</sup>]/Unit of Length, ft [m]

<sup>3</sup> Shelf surface area is composed of bottom deck plus standard shelf complement, as shown in the Hussmann *Product Reference Guide*. The standard shelf complement for this model is (5) rows of 22-inch shelves.

**Product Data (Dry Goods Area Only)**

**TOTAL Gross Usable Cube (Volume for 2 DG per merchandiser)** 10.33 ft<sup>3</sup> / (0.29 m<sup>3</sup>)

ESTIMATED SHIPPING WEIGHT <sup>4</sup>					
	2 Dr	3 Dr	4 Dr	5 Dr	Solid End (each)
<b>Standard LifeLine Premier Merchandiser (12-Inch Facade, no Arch)</b>					
<b>lb (kg)</b>	1027 (466)	1340 (608)	1655 (751)	1949 (884)	70 (32)
<b>Standard LifeLine Premier Merchandiser (18-Inch Facade, no Arch)</b>					
<b>lb (kg)</b>	1037 (470)	1355 (615)	1675 (760)	1974 (985)	75 (36)
<b>LifeLine Premier Merchandiser with Two (2) Bump Out Partitions (12-Inch Facade, no Arch)</b>					
<b>lb (kg)</b>	1206 (547)	1519 (689)	1834 (832)	2128 (965)	N/A
<b>LifeLine Premier Merchandiser with Two (2) Bump Out Partitions (18-Inch Facade, no Arch)</b>					
<b>lb (kg)</b>	1229 (557)	1547 (702)	1867 (847)	2166 (982)	N/A
<b>LifeLine Premier Merchandiser with Two (2) Dry Goods Sections, Four (4) Partitions (12-Inch Facade, no Arch)</b>					
<b>lb (kg)</b>	1507 (684)	1820 (826)	2135 (968)	NA	NA
<b>LifeLine Premier Merchandiser with Two (2) Dry Goods Sections, Four (4) Partitions (18-Inch Facade, no Arch)</b>					
<b>lb (kg)</b>	1537 (697)	1855 (841)	2175 (987)	NA	NA
<b>LifeLine Premier Merchandiser with Two (2) Bump Out Partitions, Two (2) Dry Goods Sections, Two (2) Partitions (12-Inch Facade, no Arch)</b>					
<b>lb (kg)</b>	1546 (701)	1859 (843)	2174 (986)	NA	N/A
<b>LifeLine Premier Merchandiser with Two (2) Bump Out Partitions, Two (2) Dry Goods Sections, Two (2) Partitions (18-Inch Facade, no Arch)</b>					
<b>lb (kg)</b>	1579 (716)	1897 (860)	2217 (1006)	NA	N/A
Add 10 lb (5 kg) for Arch					
<sup>4</sup> Actual weights will vary according to optional kits included.					

## Fan and Heater Circuits - Electric Defrost (standard) Low Temperature

CIRCLED NUMBERS = PARTS LIST ITEM NUMBERS  
R = Red P = Purple 2P = Purple (2 Bands) DB = Dark Blue BK = Black  
LB = Light Blue BR = Brown Y = Yellow OR = Orange W = White  
**THESE ARE MARKER COLORS (WIRE MAY VARY.)**

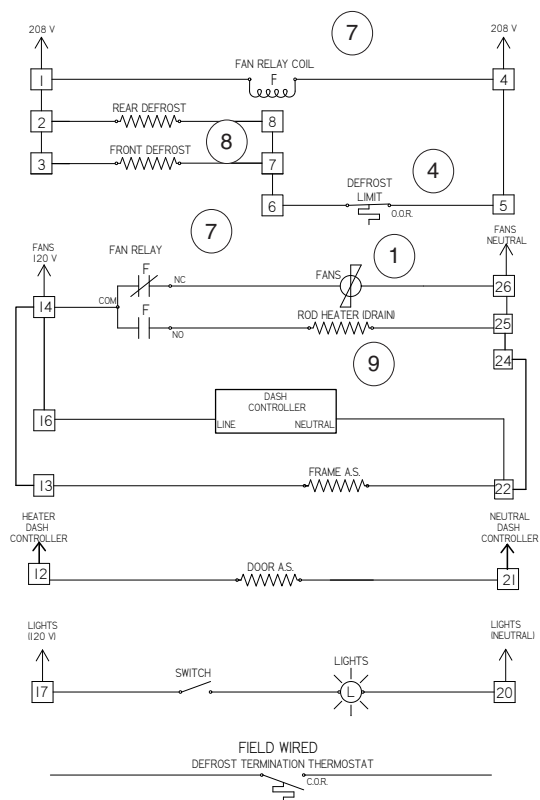

**CAUTION:** When multiplexing merchandisers equipped with defrost heaters, if branch circuit overcurrent protection is larger than the individual merchandiser's defrost circuit load, then additional supplemental overcurrent protection may be required per NEC Articles 210 and 240.

Refer to *Innovator Reach-In Glass Door, Installation and Service manual*, P/N 0425683, for *Innovator* door and frame replacement parts.

3024448\_C

THE HEAVY LINES DRAWN INSIDE THE TERMINAL BLOCKS REPRESENT PERMANENT INTERNAL JUMPERS.

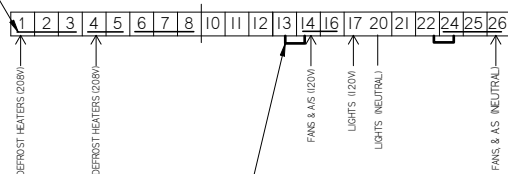

THE HEAVY LINES DRAWN OUTSIDE THE TERMINAL BLOCKS REPRESENT REMOVABLE EXTERNAL JUMPERS.

### Electric Defrost Sequence - Low Temperature

1. Power from the defrost contactor energizes Defrost Heaters and 208V Evaporator Fan Relay Coil (7). Relay Contacts open the fan circuit and energizes the Drain Pan Heater.
2. If the Defrost Heater raises internal air temperature above 90°F, the Defrost Limit Thermostat (4) will open.
3. When Defrost Termination Thermostat ends defrost period, the defrost contactor opens the Defrost Heater and Evaporator Fan Relay Coil Circuits. The Drain Pan Heater goes off and fans are on.
4. Standard low temperature Reach In cases with Innovator I doors are shipped with the DASH controller for door anti-sweat heater control installed. Do not connect the DASH controller input to a centralized anti-sweat system. It must be connected to a continuous 120V circuit for proper operation.
5. If the case is connected to a centralized anti-sweat controller that meets DOE compliance requirements, the DASH controller is not installed on the case. Feed the 120V controller output into terminal #12.
6. Options may be installed that have additional or replacement wiring diagrams.
7. Reach In cases with Innovator III doors do not have the DASH controller.



# Fan and Heater Circuits - Gas Defrost (optional)

## Low Temperature

CIRCLED NUMBERS = PARTS LIST ITEM NUMBERS  
 R = Red P = Purple 2P = Purple (2 Bands) DB = Dark Blue BK = Black  
 LB = Light Blue BR = Brown Y = Yellow OR = Orange W = White  
**THESE ARE MARKER COLORS (WIRE MAY VARY.)**

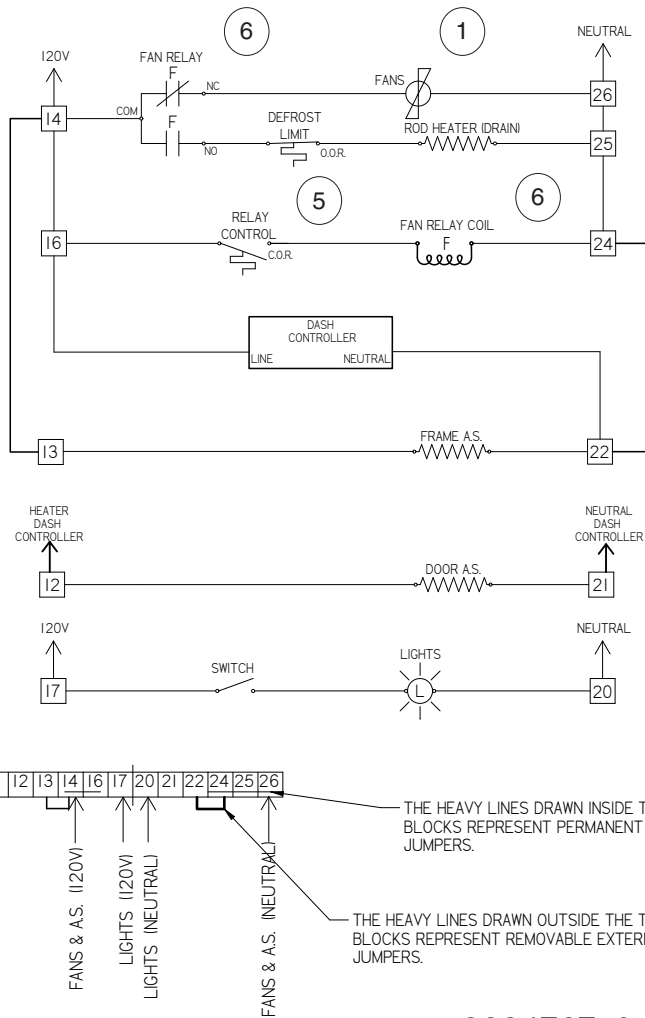

Refer to *Innovator Reach-In Glass Door, Installation and Service manual, P/N 0425683*, for *Innovator* door and frame replacement parts.

3024767\_C

### Gas Defrost Sequence - Low Temperature

1. Defrost vapor enters evaporator causing a rise in temperature. At about 35°F the Control Relay Thermostat (5) closes the Fan Relay Coil (7) and Control Relay Coil (6) circuit. The Coil opens the Fan, Door Heater, and Frame Heater circuits, while energizing the Drain Pan Heater (9).
2. If the Drain Pan Heater (9) raises internal air temperature above 90°F, the Heater Limit Thermostat (4) will open.
3. When the defrost timer ends a defrost period, the evaporator temperature will start to fall. At about 20°F, the Control Relay Thermostat will open, de-energizing the Control Relay Coil and Fan Relay Coil (7). Control and Fan Relay's will open the Drain Pan Heater circuits, and will close the Fan, Door Heater, and Frame Heater circuits.
4. Standard low temperature Reach In cases with Innovator I doors are shipped with the DASH controller for door anti-sweat heater control installed. Do not connect the DASH controller input to a centralized anti-sweat system. It must be connected to a continuous 120V circuit for proper operation.
5. If the case is connected to a centralized anti-sweat controller that meets DOE compliance requirements, the DASH controller is not installed on the case. Feed the 120V controller output into terminal #12.
6. Options may be installed that have additional or replacement wiring diagrams.
7. Reach In cases with Innovator III doors do not have the DASH controller.

# Standard Vertical Lighting Husmann EcoShine™ LED Fixtures

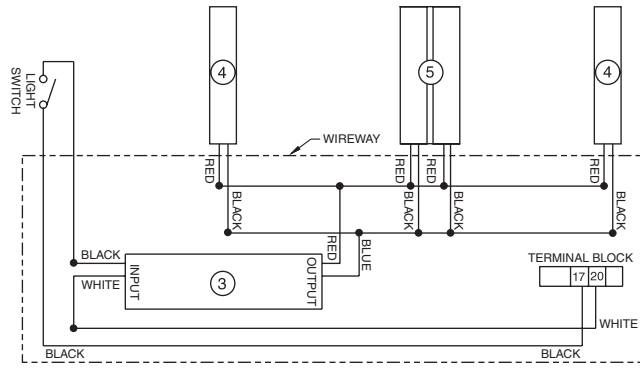

2 DOOR LED LIGHT WIRING DIAGRAM

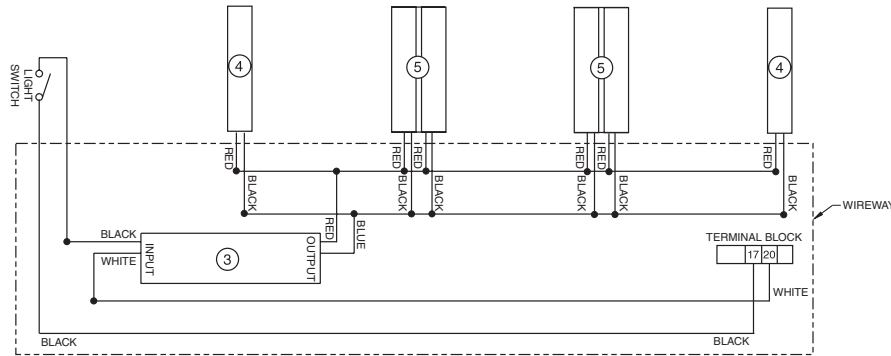

3 DOOR LED LIGHT WIRING DIAGRAM

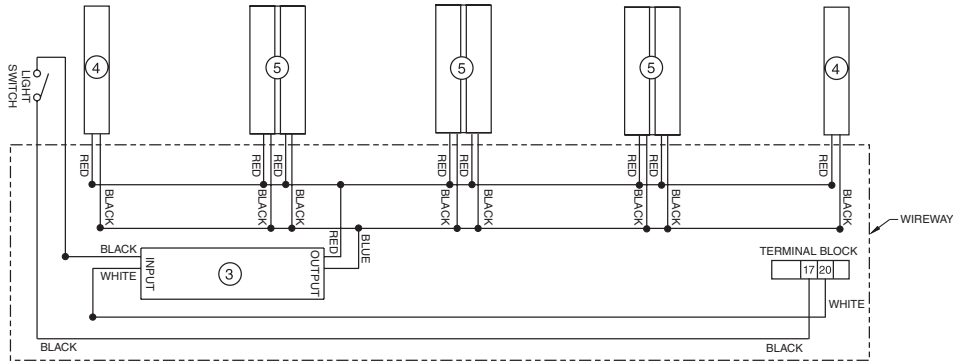

4 DOOR LED LIGHT WIRING DIAGRAM

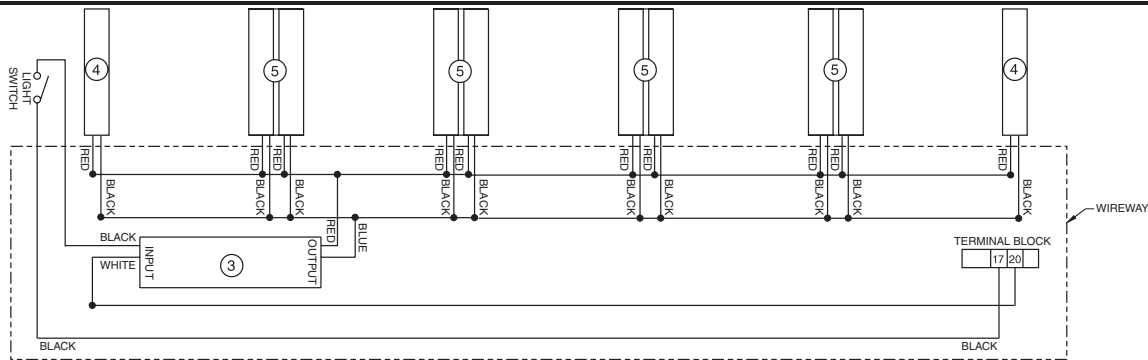

5 DOOR LED LIGHT WIRING DIAGRAM

## WARNING

All components must have mechanical ground, and the merchandiser must be grounded.

Circled numbers = Parts List Item Numbers

R = Red    Y = Yellow    G = Green    BL = Blue    BK = Black    W = White

● = 120V Power    ○ = 120V Neutral     $\perp$  = Field Ground     $\text{---}||\text{---}$  = Case Ground