

We reserve the right to change or revise specifications and product design in connection with any feature of our products. Such changes do not entitle the buyer to corresponding changes, improvements, additions or replacements for equipment previously sold or shipped.

Item	Part #	Description	Wiring Item #	Item	Part #	Description	Wiring Item #
FAN ASSEMBLIES, AND THERMOSTATS				HEATERS (CONTINUED)			
A.	4W Standard Energy Efficient Fan Assembly 0477653	Fan Motor, Evaporator (MO.4410544)	(1)	G.	Nosing Anti-sweat Heaters 0524419 8 ft case (HE.4851257) 0524421 12 ft case (HE.4851259)		(8)
	0252116	Fan Blade (FB.4780611)		H.	Return Grille Anti-sweat Heaters 0524427 8 ft case (HE.4851251) 0524429 12 ft case (HE.4851253)		(9)
B.	Optional Adj. Refrigeration Thermostat		(2)	I.	Return Glass Anti-sweat Heaters 0474778 8 ft case (GL.4987838) 0474779 12 ft case (GL.4987839)		(10)
C.	0398557	Defrost Termination Thermostat (Electric Defrost only) (CT.4440611)	(3)	J.	Discharge Glass Anti-sweat Heaters 0504300 8 ft case (GL.4969359) 0504342 12 ft case (GL.4990684)		(11)
D.	0481370	Heater Switch (Koolgas Defrost only) (CT.4440738)	(4)	GLASS LID PARTS ARE LISTED ON PAGE 5.			
HEATERS				OPTIONAL LED FIXTURES AND POWER SUPPLY			
E.	208V Evaporator Defrost Heaters 0465916 8 ft case (HE.4850630) 0465915 12 ft case (HE.4850631)		(5)	K.	0501213 Power Supply (EP.4481861)		(12)
F.	208V Drip Pan Defrost Heaters, Electric 0462160 8 ft case (HE.4850636) 0444296 12 ft case (HE.4850572)		(6)	L.	LED Fixture		(13)
	120V Drip Pan Defrost Heaters, Koolgas 0465907 8 ft case (HE.4850622) 0465908 12 ft case (HE.4850623)		(7)				

Data sheet-Excel FIG-L

Note: Revision F: removed 6 foot data. Other changes marked by bar, underline or circle.

Engineering Plan Views

PHYSICAL DATA	
Merchandiser Drip Pipe (in.)	1 1/4
Merchandiser Liquid Line (in.)	3/8
Merchandiser Suction Line (in.)	5/8

Intermediate Island Frozen Food

Dimensions shown as inches & (mm).

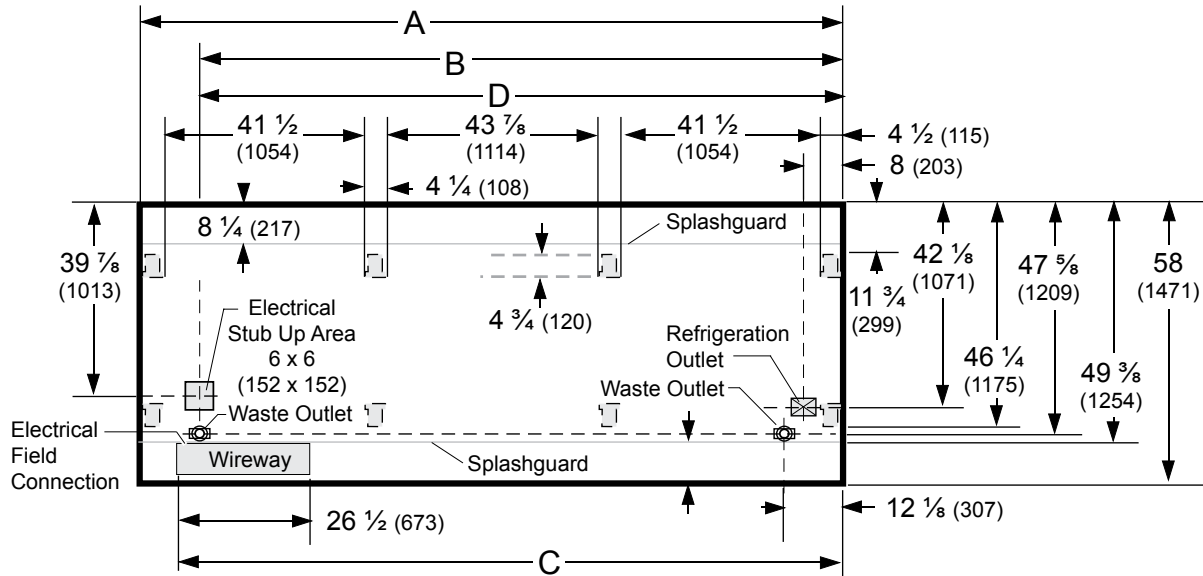

NOTE: Case-to-Case Electrical Connections are made IN FRONT OF SPLASHGUARD.

FRONT

	8 ft	12 ft
General		
(A) Case Length (without ends or partitions) (Each end and insulated partition adds 2 in. (51 mm) to case line up.) Maximum O/S dimension of case back to front (includes bumper) Back of case to front of splashguard Back of case to O/S edge of front leg Distance between edges of external legs and center legs Distance between edges of center legs Distance between front legs and splashguard	96 3/8 (2448) 58 (1471) 49 3/8 (1254) 46 1/4 (1175) 41 1/2 (1054) NA 3 1/8 (82)	144 1/2 (3670) 58 (1471) 49 3/8 (1254) 46 1/4 (1175) 41 1/2 (1054) 43 7/8 (1114) 3 1/8 (82)
Electrical Service (Electrical Field Wiring connection point)		
(B) RH End of case to center of stub up area Back of case to center of stub up area Length of electrical wireway	84 1/4 (2141) 39 7/8 (1013) 26 1/2 (673)	132 3/8 (3363) 39 7/8 (1013) 26 1/2 (673)
(C) RH End of case to LH end of wireway	90 1/8 (2289)	138 1/4 (3511)
Waste Outlets (One each end)		
(D) RH End of case to the center of LH waste outlet RH End of case to the center of RH waste outlet Back O/S of case to center of waste outlets Schedule 40 PVC drip pipe	84 1/4 (2141) 12 1/8 (307) 47 5/8 (1209) 1 1/4 (32)	132 3/8 (3363) 12 1/8 (307) 47 5/8 (1209) 1 1/4 (32)
Refrigeration Outlet		
Back of case to center of refrigeration outlet RH end of case to center of refrigeration outlet	42 1/8 (1071) 8 (203)	42 1/8 (1071) 8 (203)

Intermediate Island Display with Glass Walls and Lids



Hussmann refrigerated merchandisers configured for sale for use in the United States meet or surpass the requirements of the DOE 2017 energy efficiency standards.

Excel FIG-L
Low / Medium Temperature

REFRIGERATION DATA§

Note: This data is based on store temperature and humidity that does not exceed 75°F and 55% R.H.

Dimensions shown as inches & (mm).

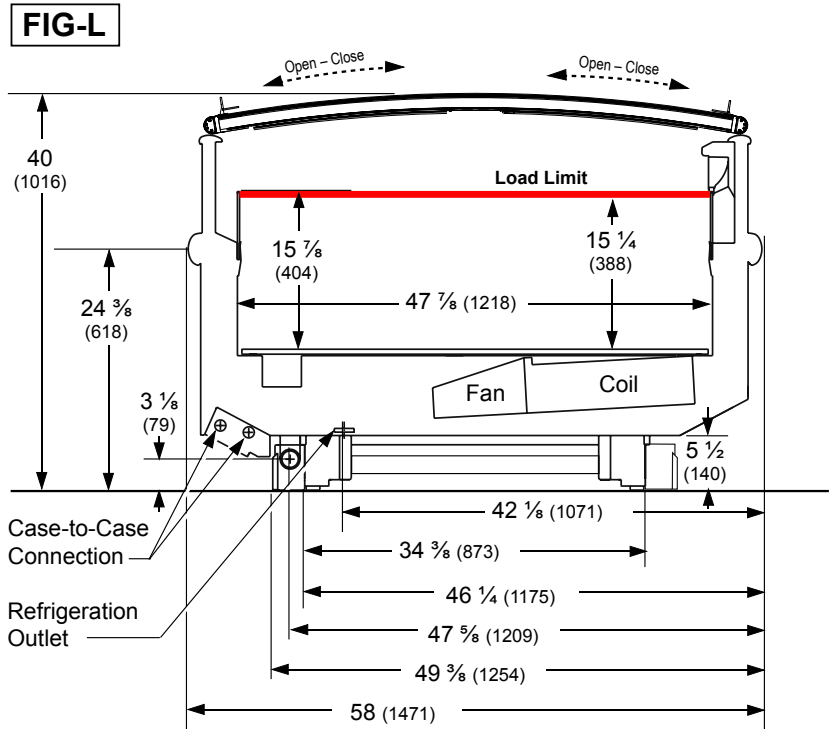

	MED	FF	IC
Discharge Air (°F)	+32	-10	-14
Evaporator (°F)	+25	-18	-20
Unit Sizing (°F)	+23	-21	-23

§ Average evaporator temperature shown. Use dew point for high glide refrigerants for unit sizing. Care should be taken to use the dew point in PT tables for measuring and adjusting superheat. Adjust evaporator pressure as needed to maintain discharge air temperature shown.

Btu/hr/ft*	MED	FF	IC
Parallel	212	290	300
Conventional	216	303	315

* Add 1.5 Btu/hr/ft for LED lighting.

DEFROST DATA

	MED	FF	IC
Frequency (hr)	24	24	24
Defrost Water (lb/ft/day)	0.2	0.2	0.15

(± 15% based on case configuration and product loading).

ELECTRIC	MED	FF	IC
Temp Term (°F)	48	48	48
Failsafe (minutes)	30	50	60

GAS	MED	FF	IC
Duration (minutes)	NA	15	18

OFFTIME Not Recommended

Standard Defrost Thermostat

Close on rise: close 48 °F — open 33 °F

CONVENTIONAL CONTROLS

Low Pressure Backup Control — CI/CO **	
MED	+28 °F / +16 °F
FF	-15 °F / -27 °F
IC	-21 °F / -33 °F

Indoor Unit Only, Pressure Defrost Termination*
Not Recommended

**Use a Temperature Pressure Chart to determine PSIG conversions.

Estimated Charge ***

8 ft	2.5 lb	40 oz	1.1 kg
12 ft	3.7 lb	59 oz	1.7 kg

***This is an average for all refrigerant types. Actual refrigerant charge may vary by approximately half a pound (8 oz/0.2 kg).

NSF Certification

This merchandiser model is manufactured to meet NSF/ANSI (National Sanitation Foundation) Standard #7 requirements for construction, materials & cleanability.

Excel FIG-L**Low / Medium Temperature****Electrical Data**

			8 ft	12 ft		
Number of Fans – 4W Evaporator			2	2		
			Amperes		Watts	
			8 ft	12 ft	8 ft	12 ft
Evaporator Fans						
120V	50/60Hz	Standard Energy Efficient	0.24	0.24	16	16
230V	50/60Hz	Standard Energy Efficient	0.12	0.12	16	16
230V	60Hz	Export	0.30	0.30	48	48
230V	50Hz	Export	0.36	0.36	54	54
Anti-sweat Heaters (on fan circuit)						
120V	50/60Hz	Standard	0.34	0.52	41	62
230V	50/60Hz	Export	0.18	0.27	41	62
Minimum Circuit Ampacity						
120V	50/60Hz	Standard Energy Efficient	0.78	1.08		
230V	50/60Hz	Standard Energy Efficient	0.50	0.65		
230V	60Hz	Export	0.68	0.92		
230V	50Hz	Export	0.74	1.01		
Maximum Over Current Protection 120V			20	20		
Maximum Over Current Protection 230V			15	15		
Return Glass Anti-sweat Heaters						
120V	50/60Hz	Standard	0.08	0.11	9	13
230V	50/60Hz	Export	0.04	0.06	9	13
Discharge Glass Anti-sweat Heaters						
120V	50/60Hz	Standard	0.46	0.66	55	79
230V	50/60Hz	Export	0.24	0.34	55	79
208V Electric Defrost (Coil & Drain Heater)			9.13	13.94	1900	2900
230V Export Electric Defrost (Coil & Drain Heater)			8.26	12.61	1900	2900
120V Koolgas Defrost			1.67	3.33	200	400

ONLY LIGHTING CONFIGURATIONS THAT ARE COMPLIANT WITH THE U.S. DEPT. OF ENERGY (DOE) 2017 REGULATION ARE AVAILABLE FOR SALE FOR USE IN THE U.S.A.

Standard Lighting

None

Optional Lighting

LED	120V	50/60Hz	0.50	0.70	60	84
LED	230V	50/60Hz	0.26	0.37	60	84

Please note: some combinations of fluorescent lights on this case model may not be compliant with DOE 2017 and may not be available to order in the US and Canada. More lighting options are available with LED lights. The Hussmann Product Configurator will not allow lighting options that do not comply with the DOE 2017 standards.

Product Data

Recommended Usable Cube ¹ (Cu Ft/Ft)	5.30 ft ³ /ft (0.49 m ³ /m)
AHRI Total Display Area ² (Sq Ft/Ft)	4.63 ft ² /ft (1.41 m ² /m)
Shelf Area ³ (Sq Ft/Ft)	4.00 ft ² /ft (1.22 m ² /m)

¹ AHRI Refrigerated Volume less shelving and other unusable space: Refrigerated Volume/Unit of Length, ft³/ft [m³/m]
² Computed using AHRI 1200 standard methodology: Total Display Area, ft² [m²]/Unit of Length, ft [m]
³ Shelf surface area is composed of bottom deck plus standard shelf complement, as shown in the Hussmann **Product Reference Guide**. The standard shelf complement for this model is NONE.

ESTIMATED SHIPPING WEIGHT ⁴			
Case	<i>8 ft</i>	<i>12 ft</i>	Solid End
			<i>(each)</i>
lb (kg)	1150 (522)	1420 (695)	50 (23)

⁴ Actual weights will vary according to optional kits included.

Glass Lid Replacement Parts

FI4GL, FI8GL, FI12GL GLASS ASSEMBLIES

S.	0524241	Top Glass - Fixed B00150 (GL.4998363)
T.	0524242	Middle Glass with Handle B00151 (GL.4998364)
U.	0524243	Bottom Glass with Handle B00152 (GL.4998365)

FI6GL GLASS ASSEMBLIES

S.	0524259	Top Glass - Fixed B00168 (GL.4998366)
T.	0524260	Middle Glass with Handle B00169 (GL.4998367)
U.	0524261	Bottom Glass with Handle B00170 (GL.4998368)

The diagram shows a perspective view of a curved glass lid assembly. It is divided into three horizontal sections by two curved lines. The bottom section is labeled 'U', the middle section is labeled 'S', and the top section is labeled 'T'. Each section is held in place by small circular fasteners along the edges.

Electric Defrost – Standard

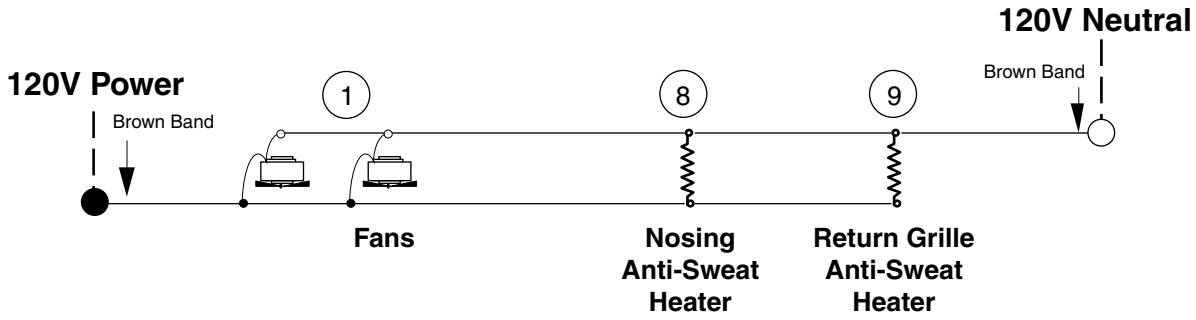

Refrigeration Thermostat (Optional)

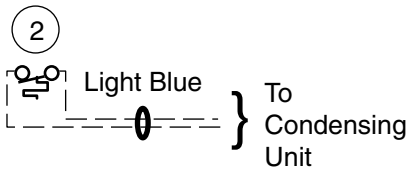

Defrost Termination Thermostat

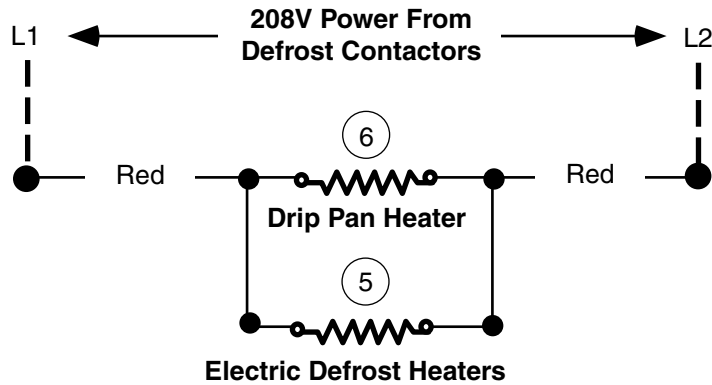
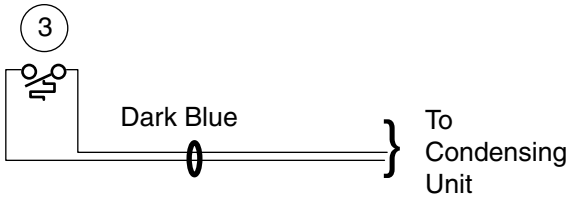

Return Glass Anti-Sweat Heater

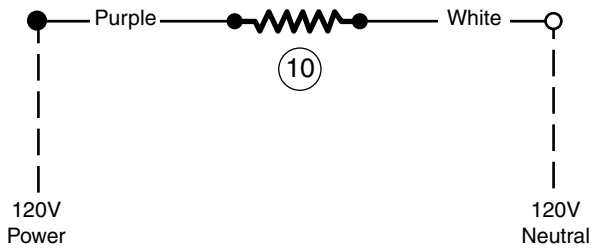

Discharge Glass Anti-Sweat Heater

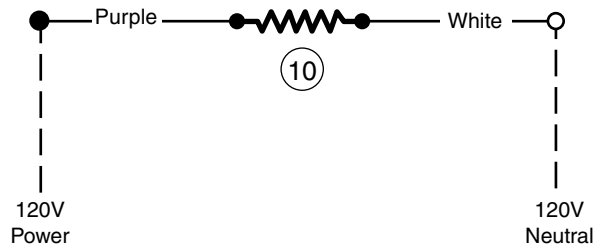

WARNING

All components must have mechanical ground, and the merchandiser must be grounded.

Circled Number = Parts List Item Numbers

Grayed components in 12 foot models only.

Gas Defrost – Optional

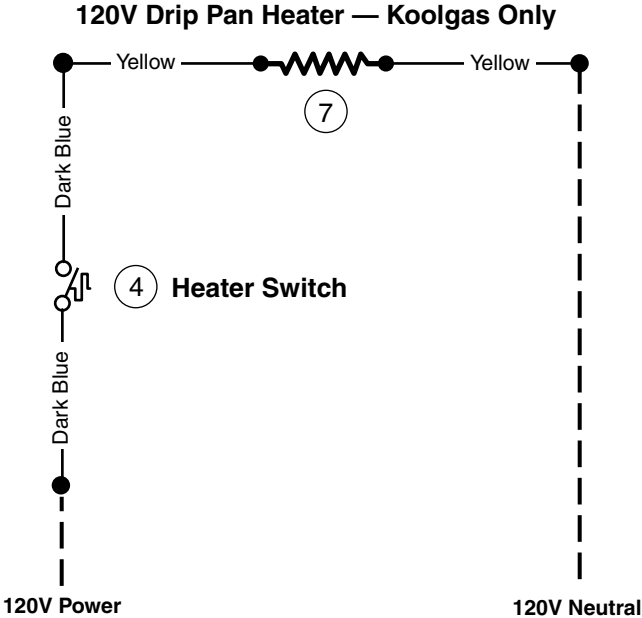

WARNING

All components must have mechanical ground, and the merchandiser must be grounded.
Circled Number = Parts List Item Numbers

Excel FIG-L
Low / Medium Temperature

Optional LED Lighting
Wiring Diagrams

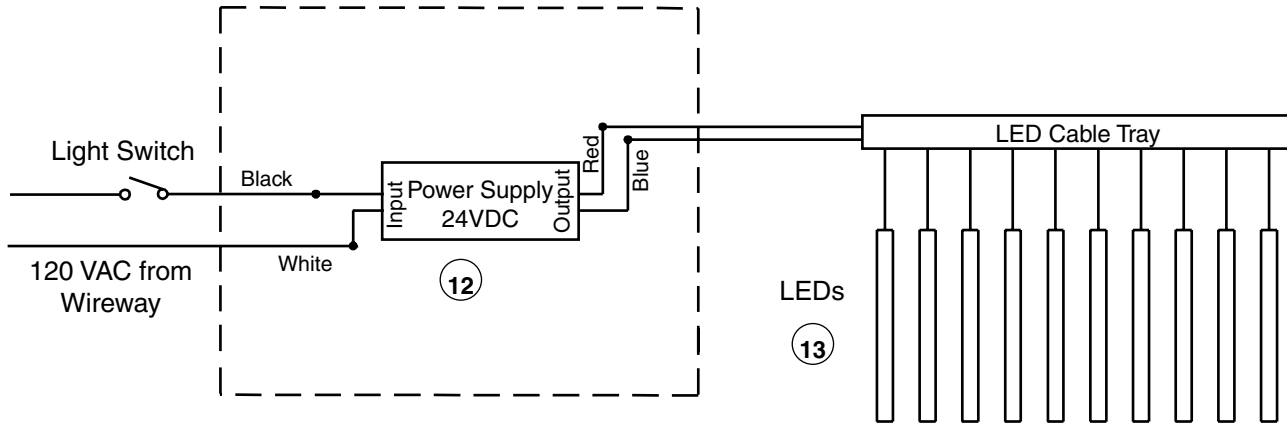

F18GL
LED Wiring Diagram

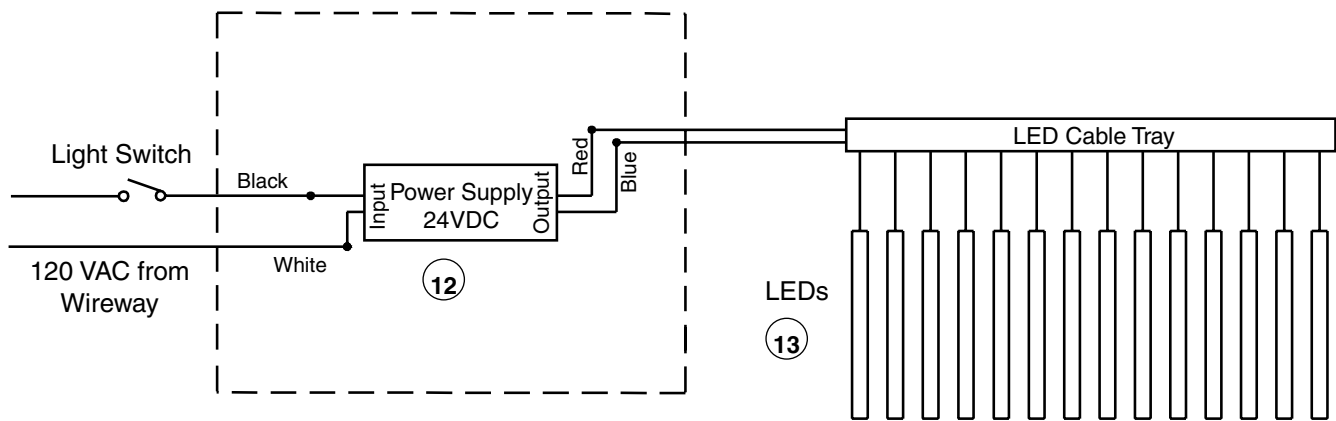

F12GL
LED Wiring Diagram