

We reserve the right to change or revise specifications and product design in connection with any feature of our products. Such changes do not entitle the buyer to corresponding changes, improvements, additions or replacements for equipment previously sold or shipped.

Item	Part #	Description	Wiring Item #	Item	Part #	Description	Wiring Item #
FAN ASSEMBLIES, AND THERMOSTATS				HEATERS			
A.	4W Standard Energy Efficient Fan Assembly	(1)		E.	208V Evaporator Defrost Heaters	(5)	
	0477653	Fan Motor, Evaporator (MO.4410544)			0444057	End case (HE.4850620)	
	0252116	Fan Blade (FB.4780611)		F.	208V Drip Pan Defrost Heaters, Electric	(6)	
B.	Optional Adjustable Refrigeration Thermostat	(2)			0444300	End case (HE.4850609)	
C.	0398557	Defrost Termination Thermostat (3)			120V Drip Pan Defrost Heaters, Koolgas	(7)	
		(Electric Defrost only)			0465906	End case (HE.4850628)	
		(CT.4440611)		G.	Nosing Anti-sweat Heaters	(8)	
D.	0481370	Heater Switch (4)			0524418	End case (HE.4851256)	
		(Koolgas Defrost only)		GLASS LID PARTS ARE LISTED ON PAGE 5.			
		(CT.4440738)		OPTIONAL LED FIXTURES AND POWER SUPPLY			
				H.	0501213	Power Supply (EP.4481861)	(9)
				J.		LED Fixture	(10)

NOTE: For LED lighting parts contact your Hussmann service representative at 1-800-922-1919. Please have your model and serial number available. Descriptions including size and color are at WWW.HUSSMANN.COM/SERVICEANDPARTS.

Note: Revision B added note on page 3.

Engineering Plan Views

PHYSICAL DATA	
Merchandiser Drip Pipe (in.)	1 1/4
Merchandiser Liquid Line (in.)	3/8
Merchandiser Suction Line (in.)	5/8

Low / Medium Temperature Wide Island End case

Dimensions shown as inches & (mm).

10-2004

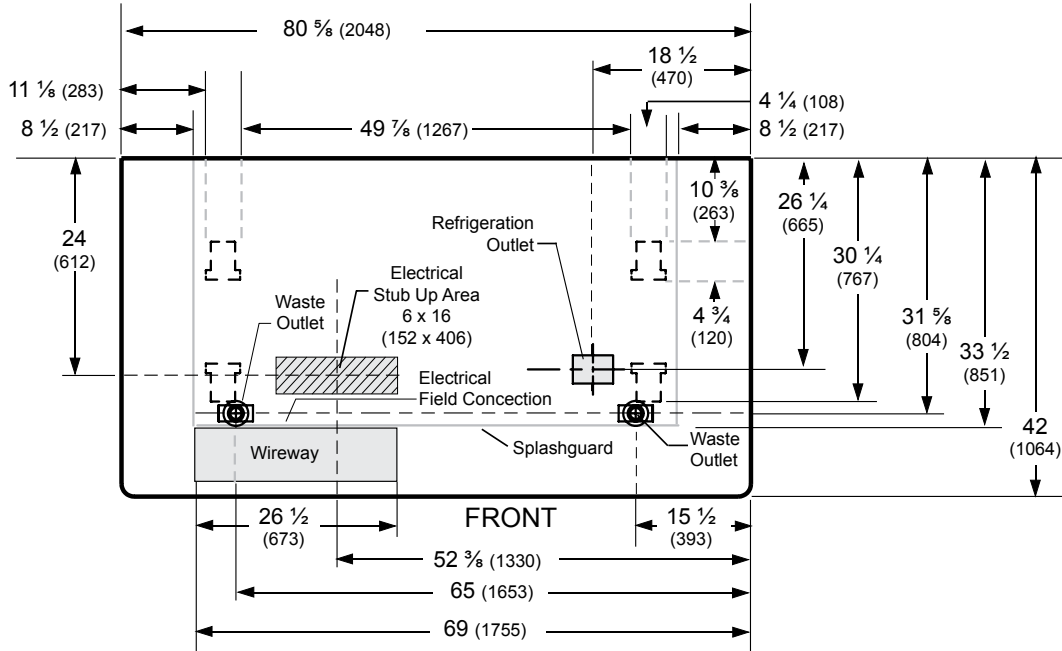

	End Case
General	
Case Length — Outside	80 5/8 (2048)
Inside Length	73 5/8 (1870)
Maximum O/S dimension of case back to front <i>(includes bumper)</i>	42 (1064)
Back of case to front of splashguard	33 1/2 (851)
Back of case to O/S edge of front leg	30 1/4 (767)
Distance between edges of external legs and center legs	48 1/2 (1234)
Distance between edges of center legs	NA
Distance between front legs and splashguard	3 1/8 (82)
Electrical Service <input checked="" type="checkbox"/> <i>(Electrical Field Wiring connection point)</i>	
RH End of case to center of stub up area	52 3/8 (1653)
Back of case to center of stub up area	24 (612)
Length of electrical wireway <input type="checkbox"/> Wireway	26 1/2 (673)
RH End of case to LH end of wireway	69 (1755)
Waste Outlets <i>(One each end)</i> <input checked="" type="checkbox"/>	
RH End of case to the center of LH waste outlet	65 (1653)
RH End of case to the center of RH waste outlet	15 1/2 (393)
Back O/S of case to center of waste outlets	31 5/8 (804)
Schedule 40 PVC drip pipe	1 1/4 (32)
Refrigeration Outlet <input checked="" type="checkbox"/>	
Back of case to center of refrigeration outlet	26 1/4 (665)
RH end of case to center of refrigeration outlet	18 1/2 (470)

Single Level End Display with Solid Front and Lids

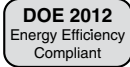

Hussmann refrigerated merchandisers configured for sale for use in the United States meet or surpass the requirements of the DOE 2012 energy efficiency standards.

Excel FWE-L
Low / Medium Temperature

REFRIGERATION DATA**

Note: This data is based on store temperature and humidity that does not exceed 75°F and 55% R.H.

	MED	FF	IC
Discharge Air (°F)	+32	-10	-19
Evaporator (°F)	+25	-15	-24
Unit Sizing (°F)	+23	-18	-27

Btu/hr/case*	MED	FF	IC
Parallel	488	922	974
Conventional	498	962	1016

* Add 10 Btu/hr/case for LED lighting.

**Dual temperature operation kits are not suitable for ice cream temperature applications.

DEFROST DATA

	MED	FF	IC
Frequency (hr)	24	24	24
Defrost Water (lb/case/day)	2.6	2.3	2.0

(± 15% based on case configuration and product loading).

ELECTRIC	MED	FF	IC
Temp Term (°F)	48	48	48
Failsafe (minutes)	30	50	60

GAS	MED	FF	IC
Duration (minutes)	NA	15	18

OFFTIME Not Recommended

Standard Defrost Thermostat

Close on rise: close 48°F — open 33°F

CONVENTIONAL CONTROLS

Low Pressure Backup Control — CI/CO **

MED	+28°F / +16°F
FF	-15°F / -27°F
IC	-21°F / -33°F

Indoor Unit Only, Pressure Defrost Termination***

Not Recommended

***Use a Temperature Pressure Chart to determine PSIG conversions.

Estimated Charge ****

End	1.5 lb	24 oz	0.7 kg
-----	--------	-------	--------

****This is an average for all refrigerant types. Actual refrigerant charge may vary by approximately half a pound (8 oz/0.2 kg).

Length Added to Lineup: 42 (1064)

This End Case is used in place of an End Assembly. Partitions do not apply.

Dimensions shown as inches & (mm).

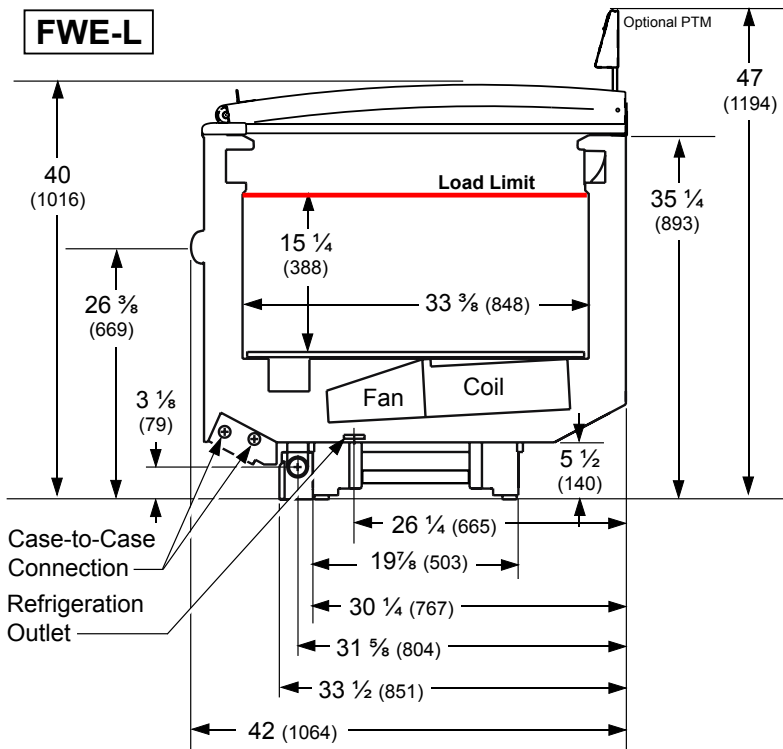

NSF Certification

This merchandiser model is manufactured to meet NSF/ANSI (National Sanitation Foundation) Standard #7 requirements for construction, materials & cleanability.

Excel FWE-L Low / Medium Temperature

Electrical Data

			Standard End	
Number of Fans – 4W Evaporator			1	
			Amperes	Watts
			End	End
Evaporator Fans				
120V	50/60Hz	Standard Energy Efficient	0.12	8
230V	50/60Hz	Standard Energy Efficient	0.06	8
230V	60Hz	Export	0.15	24
230V	50Hz	Export	0.18	27
Anti-sweat Heaters (on fan circuit)				
120V	50/60Hz	Standard	0.20	24
230V	50/60Hz	Export	0.10	24
Minimum Circuit Ampacity				
120V	50/60Hz	Standard Energy Efficient	0.52	0.92
230V	50/60Hz	Standard Energy Efficient	0.36	0.57
230V	60Hz	Export	0.45	0.66
230V	50Hz	Export	0.48	0.69
Maximum Over Current Protection 120V			20	20
Maximum Over Current Protection 230V			15	15
208V Electric Defrost			6.54	1360
230V Export Electric Defrost			5.91	1360
120V Koolgas Defrost			1.33	160
Standard Lighting				
None				
Optional Lighting				
LED	120V	50/60Hz	0.28	34
LED	230V	50/60Hz	0.15	34

Product Data

<i>Recommended Usable Cube</i> ¹ (Cu Ft/Ft)	3.54 ft ³ /ft (0.33 m ³ /m)
<i>AHRI Total Display Area</i> ² (Sq Ft/Ft)	2.60 ft ² /ft (0.79 m ² /m)
<i>Shelf Area</i> ³ (Sq Ft/Ft)	2.79 ft ² /ft (0.85 m ² /m)

¹ AHRI Refrigerated Volume less shelving and other unusable space: Refrigerated Volume/Unit of Length, ft³/ft [m³/m]

² Computed using AHRI 1200 standard methodology: Total Display Area, ft² [m²]/Unit of Length, ft [m]

³ Shelf surface area is composed of bottom deck plus standard shelf complement, as shown in the Hussmann *Product Reference Guide*. The standard shelf complement for this model is NONE.

ESTIMATED SHIPPING WEIGHT ⁴

Case						End
lb (kg)	NA (NA)	NA (NA)	NA (NA)	NA (NA)	NA (NA)	590 (269)

⁴ Actual weights will vary according to optional kits included.

Glass Lid Replacement Parts

S.	0524250	Top Glass B00159 (GL.4998354)
T.	0524251	Middle Glass B00160 (GL.4998355)
U.	0524252	Bottom Glass with Handle B00161 (GL.4998356)

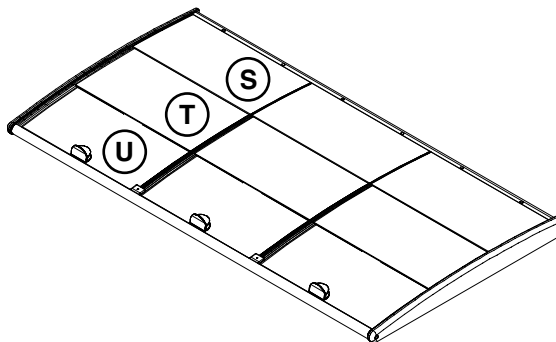

Electric Defrost – Standard

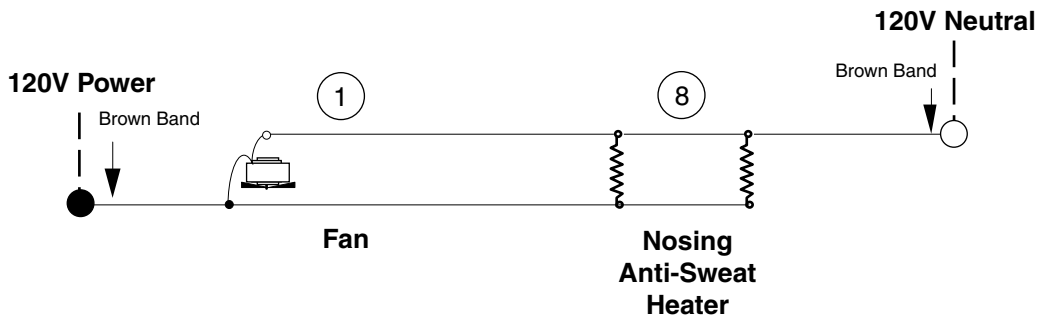

Refrigeration Thermostat (Optional)

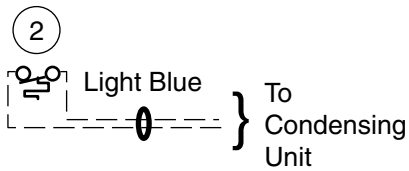

Defrost Termination Thermostat

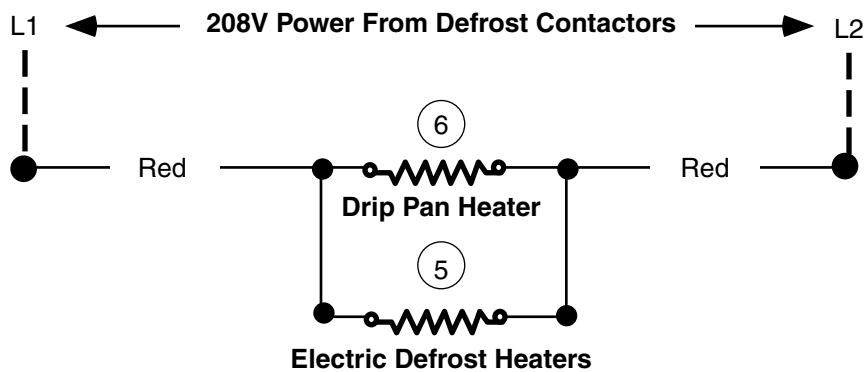
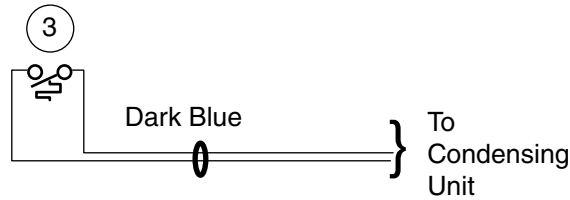

WARNING

All components must have mechanical ground, and the merchandiser must be grounded.

Circled Number = Parts List Item Numbers

Gas Defrost – Optional

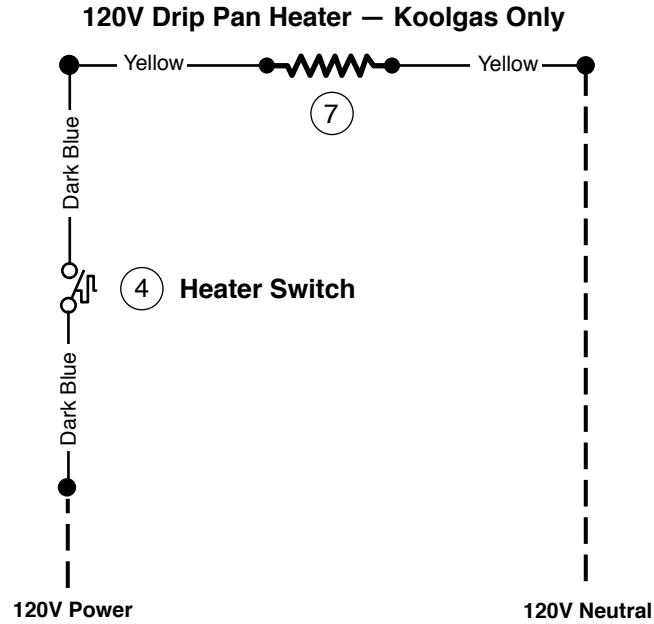

WARNING

All components must have mechanical ground, and the merchandiser must be grounded.

Circled Number = Parts List Item Numbers

Optional LED Lighting Wiring Diagrams

